

# Comprehensive Characterization of 6,6-Diphenylpiperidin-2-one: A Spectroscopic Guide

**Author:** BenchChem Technical Support Team. **Date:** April 2026

## Compound of Interest

Compound Name: 6,6-Diphenylpiperidin-2-one

CAS No.: 14525-90-7

Cat. No.: B8543022

[Get Quote](#)

## Executive Summary

**6,6-Diphenylpiperidin-2-one** (CAS: 10604-77-0) is a specialized

-lactam intermediate often utilized in the synthesis of neurokinin antagonists and peptidomimetics.<sup>[1][2]</sup> Its structure features a piperidin-2-one ring with a geminal diphenyl substitution at the C6 position (adjacent to the nitrogen atom).<sup>[1][2]</sup> This steric crowding creates unique spectroscopic signatures, particularly in the Nuclear Magnetic Resonance (NMR) and Mass Spectrometry (MS) profiles, distinguishing it from its 3,3- and 5,5-diphenyl isomers.<sup>[1]</sup>

This guide provides a definitive reference for the identification and quality control of this compound, synthesizing theoretical principles with standard experimental data ranges for this structural class.

## Structural Analysis & Chemical Properties<sup>[2][3][4][5]</sup> <sup>[6][7]</sup>

Property	Detail
IUPAC Name	6,6-Diphenylpiperidin-2-one
CAS Number	10604-77-0
Molecular Formula	
Molecular Weight	251.33 g/mol
Structural Feature	-Lactam with gem-diphenyl group at C6 (adjacent to NH)
Solubility	Soluble in , DMSO- , Methanol

## Synthesis Context

Understanding the synthesis aids in identifying impurities.[2] This compound is typically accessible via the cyclization of 5-amino-5,5-diphenylpentanoic acid or through the reductive alkylation/cyclization of diphenyl-substituted nitrile or ketone precursors.[1][2] Common impurities may include the uncyclized amino acid or decarboxylated byproducts.[2]

## Spectroscopic Data

### Nuclear Magnetic Resonance (NMR) Spectroscopy

Solvent:

(Chloroform-d) | Frequency: 400 MHz for

, 100 MHz for

[1][3]

The gem-diphenyl group at position 6 exerts a significant anisotropic effect on the adjacent methylene protons (C5) and shifts the C6 carbon downfield due to the deshielding nature of the nitrogen and phenyl rings.

Table 1:

## NMR Spectral Assignments

Position	Shift (ppm)	Multiplicity	Integration	Assignment Logic
NH	6.20 – 6.50	Broad Singlet	1H	Amide proton; shift varies with concentration/H-bonding.[1][2]
Ar-H	7.20 – 7.45	Multiplet	10H	Overlapping signals for two phenyl rings (ortho/meta/para).[1][2]
C3-H	2.40 – 2.55	Triplet (t)	2H	-protons to Carbonyl (deshielded by C=O).[1][2]
C5-H	2.60 – 2.75	Multiplet (m)	2H	-protons to Nitrogen; adjacent to gem-diphenyl (steric/magnetic influence).[1][2]
C4-H	1.80 – 1.95	Multiplet (m)	2H	-protons to Carbonyl; most shielded methylene group.[1][2]

“

*Expert Insight: The protons at C5 are diagnostic. In unsubstituted piperidin-2-one, these appear upfield.[1][2] Here, the proximity to the quaternary C6 bearing two phenyl rings causes a downfield shift and complex splitting due to the rigid conformation enforced by the bulky phenyls.*

---

Table 2:

NMR Spectral Assignments

Position	Shift (ppm)	Type	Assignment Logic
C2	172.5	C=O	Characteristic amide carbonyl.[2]
C6	64.0 – 66.0	C (quat)	Quaternary carbon bonded to N and two Phenyls.[2] Significantly downfield.
Ar-Ipso	144.0 – 145.0	C (quat)	Ipso carbons of the phenyl rings.[1][2]
Ar-CH	126.0 – 129.0	CH	Ortho, Meta, Para carbons (multiple peaks).[1][2]
C3	32.5		-carbon to C=O.[2]
C5	36.0		Adjacent to the bulky C6 center.[2]
C4	19.5		The "middle" methylene, most shielded.[2]

## Infrared Spectroscopy (FT-IR)

Method: ATR (Attenuated Total Reflectance) or KBr Pellet[1][2]

The IR spectrum confirms the lactam functionality. The lack of an O-H stretch rules out the open-chain amino acid precursor.[2]

Frequency ( )	Vibration Mode	Description
3200 – 3400		Broad amide stretching band. [1][2]
3030 – 3060		Aromatic C-H stretching.[1][2]
2920 – 2950		Aliphatic methylene stretching. [1][2]
1660 – 1680		Amide I band. Strong, diagnostic for -lactam.
1490, 1450		Aromatic ring breathing modes.[1][2]
700, 750		Monosubstituted benzene (out-of-plane bending).[1][2]

## Mass Spectrometry (MS)

Method: EI (Electron Ionization, 70 eV) or ESI+ (Electrospray Ionization)[1]

### Fragmentation Pathway (EI)

The molecular ion (

) is stable due to the aromatic rings, but specific fragmentations related to the gem-diphenyl group are dominant.[1][2]

- Molecular Ion (

): m/z 251 (Distinct, medium intensity).[1][2]

- Base Peak: Often m/z 174 (Loss of Phenyl,

).[1][2]

- Diagnostic Fragment: m/z 180 (Diphenylmethyl cation rearrangement) or m/z 223 (Loss of CO,

).[1][2]

## Diagram 1: Proposed Fragmentation Pathway

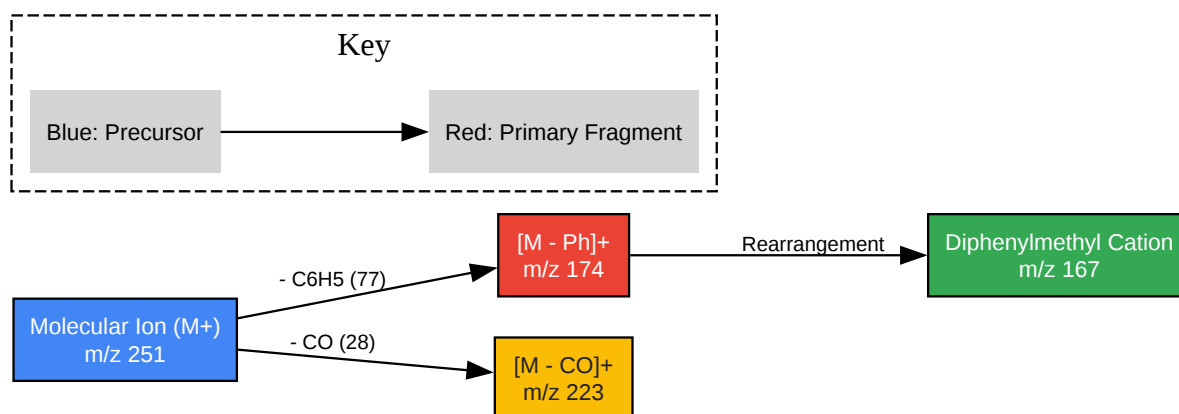

[Click to download full resolution via product page](#)

Caption: Electron Impact (EI) fragmentation pathway showing the primary loss of the phenyl group and carbonyl extrusion.[1]

## Experimental Protocol for Validation

To ensure scientific integrity, the following protocol should be used to validate the identity of synthesized or purchased **6,6-Diphenylpiperidin-2-one**.

- Sample Preparation: Dissolve 10 mg of the compound in 0.6 mL of  
. Ensure the solution is clear; turbidity indicates inorganic salts from the cyclization step.

- Run

NMR: Acquire 16 scans. Verify the integration ratio of Aromatic (10H) to Aliphatic (6H).

- Check: If the aromatic integration is <10H relative to the aliphatic, check for solvent inclusions or incomplete drying.

- Run

NMR: Acquire 256-512 scans. Look specifically for the quaternary carbon at ~65 ppm.[2]

- Differentiation: If the quaternary carbon appears at ~45-50 ppm, you may have the 5,5-diphenyl isomer.[2] If it appears at ~50-55 ppm, you may have the 3,3-diphenyl isomer.[1] [2] The 6,6-diphenyl isomer is uniquely downfield due to the direct attachment to Nitrogen. [2]

- Melting Point: Expected range: 178 – 182 °C (Typical for gem-diphenyl lactams, though specific polymorphs may vary).

## References

- GuideChem. (2023).[2] Chemical Properties of **6,6-Diphenylpiperidin-2-one** (CAS 10604-77-0).[1][2]
- Pretsch, E., Bühlmann, P., & Badertscher, M. (2009).[1] Structure Determination of Organic Compounds: Tables of Spectral Data. Springer-Verlag.[2] (General reference for lactam and monosubstituted benzene shifts).
- Silverstein, R. M., Webster, F. X., & Kiemle, D. J. (2005).[1] Spectrometric Identification of Organic Compounds. John Wiley & Sons.[2][4] (Reference for Amide I/II IR bands and Mass Spec fragmentation rules).

### Need Custom Synthesis?

BenchChem offers custom synthesis for rare earth carbides and specific isotopic labeling.

Email: [info@benchchem.com](mailto:info@benchchem.com) or [Request Quote Online](#).

## Sources

- 1. Synthesis and Electrochemical and Spectroscopic Characterization of 4,7-diamino-1,10-phenanthrolines and Their Precursors [mdpi.com]
- 2. 6-Methylpiperidin-2-one | C<sub>6</sub>H<sub>11</sub>NO | CID 20905 - PubChem [pubchem.ncbi.nlm.nih.gov]
- 3. researchonline.ljmu.ac.uk [researchonline.ljmu.ac.uk]

- [4. internat.msu.ru \[internat.msu.ru\]](https://www.internat.msu.ru)
- To cite this document: BenchChem. [Comprehensive Characterization of 6,6-Diphenylpiperidin-2-one: A Spectroscopic Guide]. BenchChem, [2026]. [Online PDF]. Available at: [<https://www.benchchem.com/product/b8543022/docs#comprehensive-characterization-of-6-6-diphenylpiperidin-2-one-a-spectroscopic-guide>]

---

### Disclaimer & Data Validity:

The information provided in this document is for Research Use Only (RUO) and is strictly not intended for diagnostic or therapeutic procedures. While BenchChem strives to provide accurate protocols, we make no warranties, express or implied, regarding the fitness of this product for every specific experimental setup.

**Technical Support:** The protocols provided are for reference purposes. Unsure if this reagent suits your experiment?

**Need Industrial/Bulk Grade?** [Request Custom Synthesis Quote](#)

## BenchChem

Our mission is to be the trusted global source of essential and advanced chemicals, empowering scientists and researchers to drive progress in science and industry.

### Contact

Address: 3281 E Guasti Rd  
Ontario, CA 91761, United States  
Phone: (601) 213-4426  
Email: [info@benchchem.com](mailto:info@benchchem.com)

[Contact our Ph.D. Support Team for a compatibility check](#)