

Technical Support Center: Acylation of 3-Substituted Thiophenes

Author: BenchChem Technical Support Team. **Date:** April 2026

Compound of Interest

Compound Name: *3-Chloro-1-(3-thienyl)-1-propanone*

Cat. No.: *B8535820*

[Get Quote](#)

Subject: Optimization of Yield & Regioselectivity in Friedel-Crafts Processes Status: Operational Lead Scientist: Dr. H. Vance, Senior Application Scientist

Executive Summary

Acylation of a 3-substituted thiophene is deceptively complex. Unlike benzene, the thiophene ring is electron-rich (super-aromatic) and prone to acid-catalyzed polymerization ("tarring"). Furthermore, the presence of a substituent at C3 creates a competition between the electronically favored C2 position (ortho to the substituent) and the sterically less hindered C5 position (meta to the substituent).

This guide troubleshoots the three most common failure modes: Polymerization (Tar formation), Regio-scrambling (C2 vs. C5 mixtures), and Catalyst Deactivation.

Part 1: Troubleshooting Guides (Q&A)

Category A: Yield & Reactivity Issues

Q: My reaction mixture turns into a black tar immediately upon adding the catalyst. How do I prevent this? A: This is the "Thiophene Polymerization Trap." Thiophenes are unstable in the

presence of strong Lewis acids (like AlCl_3) unless an electrophile is immediately available.

- The Cause: Adding AlCl_3 directly to the thiophene initiates cationic polymerization before acylation can occur.
- The Fix (Inverse Addition): Never add the catalyst to the thiophene. Instead, generate the acylium ion complex first.
 - Dissolve the Acyl Chloride (1.1 eq) in DCM or DCE.
 - Add AlCl_3 (1.2 eq) at 0°C and stir until the complex forms (often a color change).
 - Slowly add the 3-substituted thiophene (1.0 eq) as a solution in DCM to this pre-formed complex.
- Alternative: For highly sensitive electron-rich substrates (e.g., 3-methoxythiophene), switch to a milder catalyst like SnCl_4 or ZnCl_2 , which are less likely to initiate polymerization than AlCl_3 .

Q: The reaction stalls at 50-60% conversion. Adding more heat just causes decomposition. A: You are likely experiencing the "Product Inhibition Effect." The acylated thiophene product is a ketone, which is a Lewis base. It coordinates strongly with the Lewis acid catalyst, effectively removing it from the cycle.

- The Fix: Adjust stoichiometry. You need at least 1.1 to 1.5 equivalents of Lewis acid relative to the acylating agent, not just catalytic amounts. If using an anhydride, you need >2.2 equivalents of catalyst (one to activate the anhydride, one to complex the leaving carboxylate, and excess to drive the reaction).

Q: I am acylating 3-bromothiophene, but the yield is <30%. A: 3-Bromothiophene is deactivated compared to alkyl-thiophenes.

- The Fix: Increase the "Hardness" of the conditions.
 - Switch solvent to Nitromethane or Nitrobenzene. These polar solvents stabilize the acylium intermediate, increasing its electrophilicity.

- Increase temperature to reflux (DCM: 40°C or DCE: 83°C).
- Ensure anhydrous conditions; moisture kills the active acylium species instantly.

Category B: Regioselectivity (The "2 vs 5" Problem)

Q: I need the 2-acyl isomer (2,3-substitution pattern), but I see significant 5-acyl impurity. A: The C2 position is electronically favored (alpha to sulfur, ortho to substituent), but steric hindrance from the C3 group can push reaction to C5.

- The Fix: Use a smaller acylating agent if possible (e.g., acetyl chloride vs. pivaloyl chloride).
- The Fix: Lower the temperature (-78°C to -20°C). Lower temperatures favor the kinetic product (C2 attack) over the thermodynamic or sterically driven product.

Q: I specifically need the 5-acyl isomer (2,4-substitution pattern). Can I force the reaction to C5? A: Directing acylation to C5 on a 3-substituted thiophene is difficult without blocking groups because C2 is so reactive.

- Strategy 1 (Steric Control): If the substituent at C3 is bulky (e.g., t-butyl or isopropyl), the C2 position is shielded, naturally favoring C5.
- Strategy 2 (The Blocking Group Protocol):
 - Brominate C2 selectively (NBS/DMF)

2-bromo-3-alkylthiophene.
 - Acylate at C5 (now the only open alpha position).
 - Debrominate (Zn/acetic acid or Pd/C/H₂).

Part 2: Optimized Experimental Protocol

Protocol: High-Yield Acylation of 3-Methylthiophene (Targeting C2-Acylation) Rationale: This protocol uses the "Perrier Mode" (pre-forming the electrophile) to eliminate polymerization.

Reagents:

- 3-Methylthiophene (1.0 equiv)
- Acetyl Chloride (1.2 equiv)
- Aluminum Chloride (AlCl_3), anhydrous (1.3 equiv)
- Dichloromethane (DCM), anhydrous (0.5 M concentration)

Step-by-Step:

- Catalyst Activation: Flame-dry a 3-neck round-bottom flask under N_2 atmosphere. Add anhydrous DCM and AlCl_3 . Cool to 0°C .
- Acylium Formation: Add Acetyl Chloride dropwise. Stir at 0°C for 15-30 mins. The suspension should clarify or change color, indicating the formation of the complex.
- Controlled Addition: Dissolve 3-Methylthiophene in a small volume of DCM. Add this solution dropwise to the catalyst mixture over 30 minutes. Crucial: Keep internal temp $< 5^\circ\text{C}$.
- Reaction: Allow to warm to Room Temperature (RT) and stir for 2-4 hours. Monitor by TLC/GC.
- Quench: Pour the reaction mixture slowly into a beaker of crushed ice/HCl. Do not add water to the reaction flask (violent exotherm).
- Workup: Extract with DCM (3x). Wash organic layer with NaHCO_3 (sat.) to remove acid, then Brine.^[1] Dry over MgSO_4 .^[1]

Data: Catalyst & Condition Comparison

Substrate (3-R)	Catalyst	Solvent	Temp	Yield	Major Isomer	Notes
3-Methyl	AlCl ₃	DCM	0°C	85-92%	C2 (90:10)	Standard high-yield protocol.
3-Methyl	SnCl ₄	DCM	RT	75%	C2 (95:5)	Milder; less tar, higher regioselectivity.
3-Methoxy	AlCl ₃	DCM	0°C	0%	N/A	Failed. Polymerized instantly.
3-Methoxy	SnCl ₄	Benzene	0°C	65%	C2	Requires mild Lewis acid.
3-Bromo	AlCl ₃	DCM	Reflux	55%	C2 (Mixture)	Deactivated ring; requires heat.

Part 3: Visualizing the Logic

Figure 1: Regioselectivity & Mechanism Pathway

Caption: Electronic activation directs attack to C2, while steric bulk at C3 pushes attack to C5.

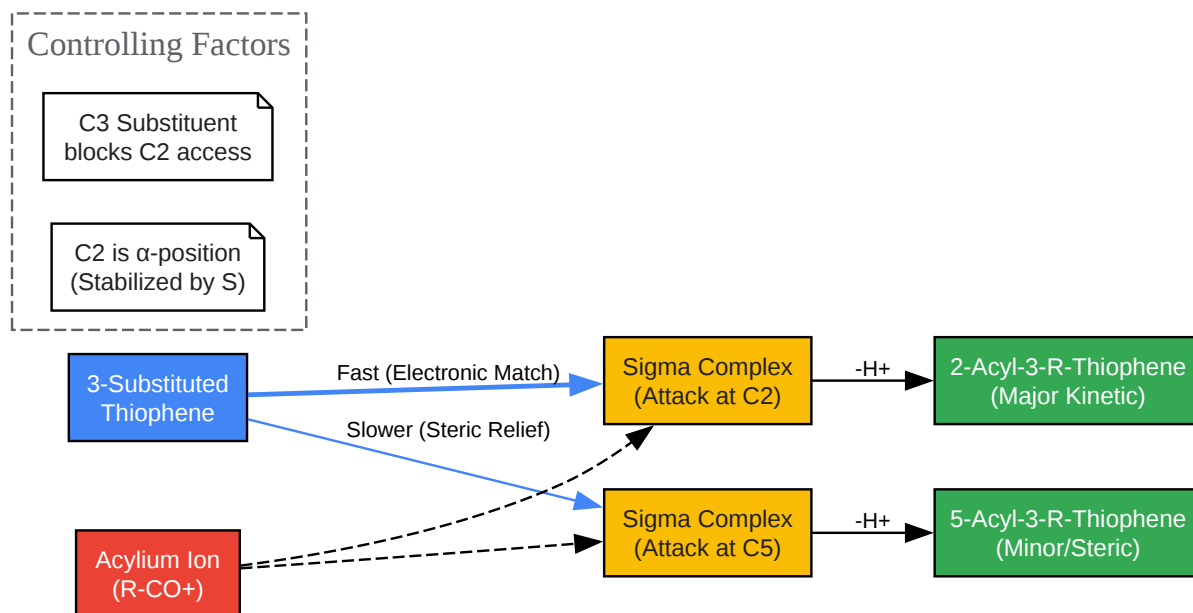

[Click to download full resolution via product page](#)

Figure 2: Troubleshooting Decision Tree

Caption: Step-by-step logic to resolve low yield or polymerization issues.

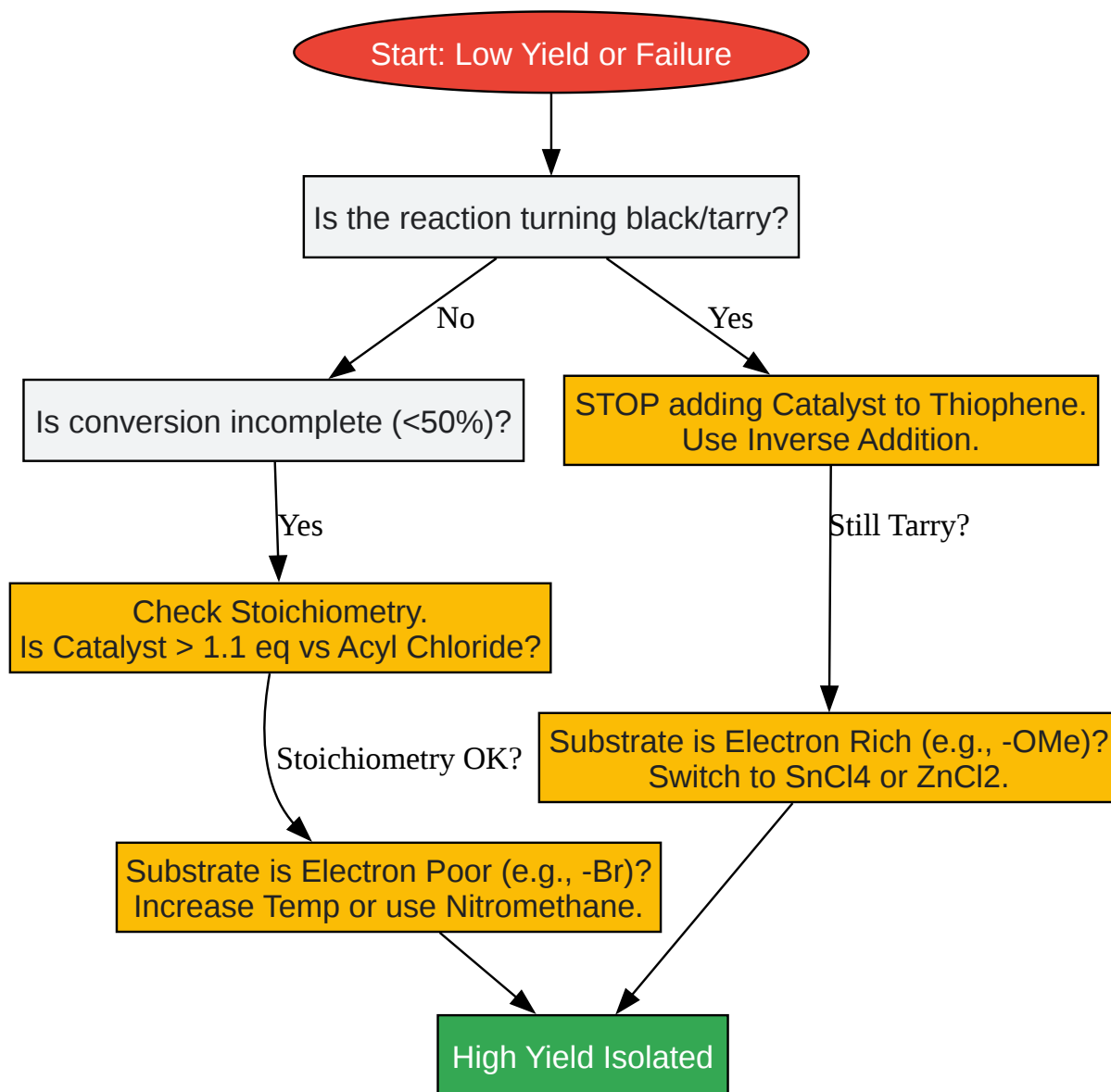

[Click to download full resolution via product page](#)

References

- Beilstein Journals. (2016). Regiocontrolled Pd-catalysed C5-arylation of 3-substituted thiophene derivatives using a bromo-substituent as blocking group. Retrieved from [[Link](#)]
- ResearchGate. (2025). Direction of 3-bromothiophene acylation with succinyl chloride. Retrieved from [[Link](#)]

- TSI Journals. (2014). Mild liquid-phase friedel-crafts acylation of thiophene to 2-acetylthiophene over solid-acid catalysts. Retrieved from [[Link](#)]
- ResearchGate. (2025). Regioselective Electrophilic Formylation — 3-Substituted Thiophenes as a Case Study. Retrieved from [[Link](#)]

Need Custom Synthesis?

BenchChem offers custom synthesis for rare earth carbides and specific isotopic labeling.

Email: info@benchchem.com or [Request Quote Online](#).

Sources

- 1. pdf.benchchem.com [pdf.benchchem.com]
- To cite this document: BenchChem. [Technical Support Center: Acylation of 3-Substituted Thiophenes]. BenchChem, [2026]. [Online PDF]. Available at: [<https://www.benchchem.com/product/b8535820/docs#technical-support-center-acylation-of-3-substituted-thiophenes>]

Disclaimer & Data Validity:

The information provided in this document is for Research Use Only (RUO) and is strictly not intended for diagnostic or therapeutic procedures. While BenchChem strives to provide accurate protocols, we make no warranties, express or implied, regarding the fitness of this product for every specific experimental setup.

Technical Support: The protocols provided are for reference purposes. Unsure if this reagent suits your experiment?

Need Industrial/Bulk Grade? [Request Custom Synthesis Quote](#)

BenchChem

Our mission is to be the trusted global source of essential and advanced chemicals, empowering scientists and researchers to drive progress in science and industry.

Contact

Address: 3281 E Guasti Rd

Ontario, CA 91761, United States

Phone: (601) 213-4426

Email: info@benchchem.com

[Contact our Ph.D. Support Team for a compatibility check](#)