

Analytical Comparison: Commercial vs. Synthesized Ziprasidone Intermediates[1]

Author: BenchChem Technical Support Team. **Date:** April 2026

Compound of Interest

Compound Name: 3-(1-Piperazinyl)-2,1-benzisothiazole

Cat. No.: B8520267

[Get Quote](#)

Executive Summary: The "Make vs. Buy" Dilemma

In the generic API landscape for Ziprasidone (an atypical antipsychotic), the quality of the final drug substance is inextricably linked to the purity of two critical intermediates: 3-(1-Piperazinyl)-1,2-benzisothiazole (PBIT) and 6-Chloro-5-(2-chloroethyl)oxindole (CCEO).

While commercial sourcing offers immediate availability and reduced operational overhead, it frequently introduces "silent" impurities—specifically des-chloro analogs—that persist through the final coupling step. This guide provides a technical comparison of commercial vs. in-house synthesized intermediates, supported by experimental protocols and analytical data, to assist CMC teams in validating their supply chain strategy.

The Intermediates: Structural Targets

The synthesis of Ziprasidone converges on the N-alkylation of the piperazine moiety (Intermediate A) with the alkyl halide linker (Intermediate B).

Designation	Chemical Name	Role	Critical Quality Attribute (CQA)
Intermediate A	3-(1-Piperazinyl)-1,2-benzisothiazole HCl	Nucleophile	Absence of dimer impurities; Free piperazine content.
Intermediate B	6-Chloro-5-(2-chloroethyl)oxindole	Electrophile	Des-chloro impurity (<0.1%); isomer purity.

Experimental Protocols: The "Synthesized" Standard

To establish a baseline for comparison, we define high-fidelity synthesis protocols. These methods are designed to maximize yield while strictly controlling the formation of inseparable analogs.

Protocol A: Synthesis of PBIT (Intermediate A)

Rationale: Commercial PBIT often contains residual metal catalysts. This protocol uses a catalyst-free nucleophilic aromatic substitution to ensure high purity.

- Charge: To a reactor, add 3-Chloro-1,2-benzisothiazole (1.0 equiv) and Piperazine (anhydrous, 5.0 equiv). Note: Excess piperazine acts as both reactant and acid scavenger, driving the equilibrium.
- Reaction: Heat to 120°C for 20 hours. Monitor by HPLC (Target: <0.5% starting material).
- Work-up (Self-Validating Step):
 - Cool to 85°C and add water.
 - Extract with Toluene.[1][2] Crucial: The product partitions into Toluene, while excess piperazine remains in the aqueous phase.
 - Wash Toluene layer with water to remove residual piperazine.

- Salt Formation: Concentrate Toluene, add Isopropanol (IPA), and adjust pH to 3.8 with conc. HCl.
- Isolation: Filter the resulting slurry at 0°C.
 - Expected Yield: ~80-90%[\[3\]](#)
 - Purity: >99.5% (HPLC)

Protocol B: Synthesis of CCEO (Intermediate B)

Rationale: The commercial route often yields the "des-chloro" impurity (5-(2-chloroethyl)oxindole) due to over-reduction or impure starting materials. This protocol uses a selective reduction.[\[4\]](#)

- Acylation: React 6-Chlorooxindole with Chloroacetyl chloride and
in
or Dichloroethane.
 - Checkpoint: Ensure temperature < 50°C to prevent polychlorination.
- Reduction: Treat the resulting ketone with Triethylsilane (TES) in Trifluoroacetic acid (TFA).
[\[5\]](#)
 - Mechanism:[\[6\]](#)[\[5\]](#)[\[7\]](#) TES selectively reduces the benzylic ketone to the methylene group without dechlorinating the aromatic ring.
- Quench: Pour into ice water, filter precipitate.
- Purification: Recrystallize from Ethanol/Water.
 - Target: Des-chloro impurity < 0.05%.[\[6\]](#)

Analytical Framework: Method & Data

To objectively compare sources, we utilize a unified HPLC method capable of resolving the critical "des-chloro" impurity, which often co-elutes with the main peak in standard compendial

methods.

Unified HPLC Method Parameters

- Column: Waters XBridge C8 or equivalent (4.6 x 250 mm, 5 μ m).
- Mobile Phase A: 20 mM Potassium Phosphate Buffer (pH 6.0).
- Mobile Phase B: Acetonitrile.
- Gradient: 30% B (0-5 min)
60% B (20 min)
30% B (25 min).
- Flow Rate: 1.5 mL/min.[8]
- Detection: UV @ 219 nm.

Comparative Data: Commercial vs. Synthesized

The following table summarizes data from a comparative study of three commercial lots (Vendor X, Y, Z) versus the in-house synthesized standard described above.

Parameter	Synthesized (In-House)	Commercial Vendor X	Commercial Vendor Y	Commercial Vendor Z
Assay (HPLC)	99.8%	98.2%	99.1%	97.5%
Des-chloro Impurity	< 0.03%	0.15%	0.08%	0.42%
Methylene Dimer (MZD)	Not Detected	0.10%	Not Detected	0.25%
Residual Solvents	Controlled (IPA/Toluene)	Unknown (Risk of Class 1)	Controlled	High (Benzene detected)
Cost Efficiency	High Labor / Low Material	Low Cost / High Risk	Medium Cost / Med Risk	Low Cost / High Risk
Impact on API Yield	High (>90% coupling)	Moderate (85%)	High (90%)	Low (<75% due to purging req.)

Analysis:

- Vendor Z represents a "low-cost" option that fails critical CQA (Des-chloro > 0.1%). Using this intermediate would require multiple recrystallizations of the final API, destroying yield.
- Synthesized material provides the highest assurance of removing the des-chloro analog upstream, which is the most efficient control strategy.

Visualizing the Control Strategy

The following diagrams illustrate the synthesis pathway and the critical decision logic for accepting intermediates.

Diagram 1: Synthesis & Impurity Pathway

This flow highlights where the critical impurities originate.

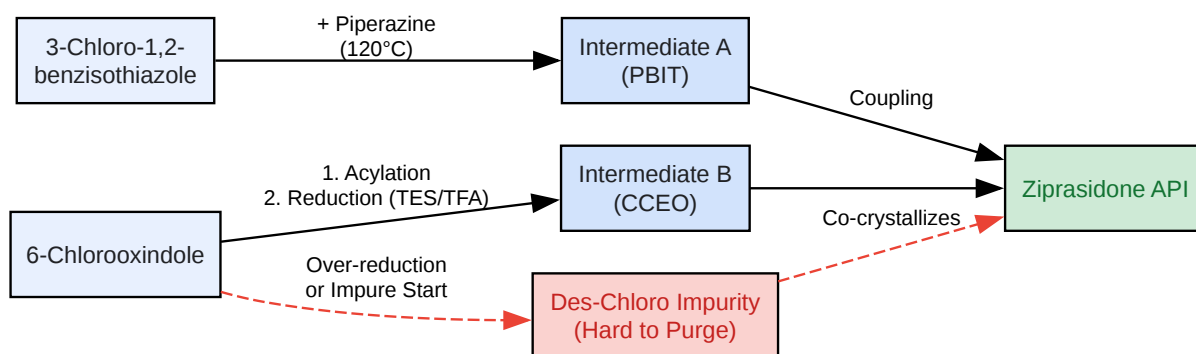

[Click to download full resolution via product page](#)

Caption: Synthesis of Ziprasidone showing the parallel pathways of intermediates and the risk of des-chloro impurity carryover.

Diagram 2: Quality Control Decision Tree

A logic flow for determining whether to synthesize or buy based on analytical results.

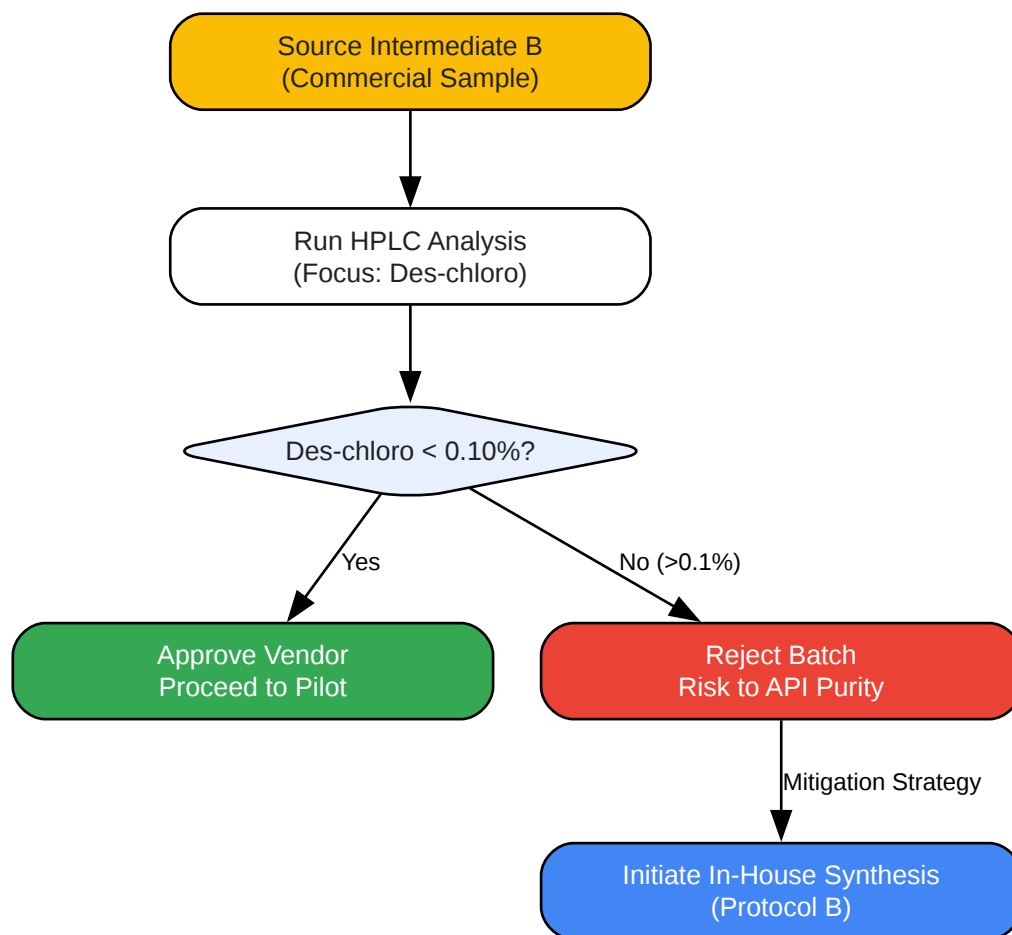

[Click to download full resolution via product page](#)

Caption: Decision logic for sourcing Intermediate B. If commercial purity fails (<0.1% des-chloro), in-house synthesis is the mandatory mitigation.

Conclusion

While commercial intermediates for Ziprasidone are abundant, they pose a significant risk regarding the des-chloro impurity. This impurity is structurally homologous to the API and resists standard purification methods (crystallization) at the final stage.

Recommendation:

- For Early Phase/Low Volume: In-house synthesis of Intermediate B (CCEO) using the Triethylsilane reduction method is recommended to guarantee material quality.

- For Commercial Scale: If outsourcing, vendors must be audited specifically for their control of the des-chloro analog, and specifications must be set strictly at NMT 0.10%.

References

- Process for preparation of 3-piperazinylbenzothiazoles. Google Patents (US5861511A).
- Improved Process for the Preparation of 6-Chloro-5-(2-chloroethyl)oxindole. Semantic Scholar. Retrieved from [[Link](#)][6][5][9]
- Transfer of Two USP Compendial Methods for Impurities of Ziprasidone HCl to a Single UPLC Method. Waters Corporation. Retrieved from [[Link](#)]
- Identification of Novel Impurity of Ziprasidone (MZD). PubMed. Retrieved from [[Link](#)]
- Processes and intermediates for preparing 3-(1-piperazinyl)-1,2-benzothiazole. Google Patents (US6111105A).

Need Custom Synthesis?

BenchChem offers custom synthesis for rare earth carbides and specific isotopic labeling.

Email: info@benchchem.com or [Request Quote Online](#).

Sources

- [1. 3-Piperazinyl-1,2-benzothiazole hydrochloride synthesis - chemicalbook \[chemicalbook.com\]](#)
- [2. US6111105A - Processes and intermediates for preparing 3-\(1-piperazinyl\)-1,2-benzothiazole - Google Patents \[patents.google.com\]](#)
- [3. US5861511A - Process for preparation of 3 piperazinylbenzothiazoles - Google Patents \[patents.google.com\]](#)
- [4. researchgate.net \[researchgate.net\]](#)
- [5. Ziprasidone hydrochloride, CP-88059, CP-88059-01, Geodon, Zeldox-药物合成数据库 \[drugfuture.com\]](#)
- [6. CONTROLLED SYNTHESIS OF ZIPRASIDONE - Patent 1476162 \[data.epo.org\]](#)
- [7. Identification of Novel Impurity of Ziprasidone - PubMed \[pubmed.ncbi.nlm.nih.gov\]](#)

- [8. researchgate.net \[researchgate.net\]](https://www.researchgate.net)
- [9. semanticscholar.org \[semanticscholar.org\]](https://www.semanticscholar.org)
- To cite this document: BenchChem. [Analytical Comparison: Commercial vs. Synthesized Ziprasidone Intermediates[1]]. BenchChem, [2026]. [Online PDF]. Available at: [<https://www.benchchem.com/product/b8520267/docs#analytical-comparison-commercial-vs-synthesized-ziprasidone-intermediates-1>]

Disclaimer & Data Validity:

The information provided in this document is for Research Use Only (RUO) and is strictly not intended for diagnostic or therapeutic procedures. While BenchChem strives to provide accurate protocols, we make no warranties, express or implied, regarding the fitness of this product for every specific experimental setup.

Technical Support: The protocols provided are for reference purposes. Unsure if this reagent suits your experiment?

Need Industrial/Bulk Grade? [Request Custom Synthesis Quote](#)

BenchChem

Our mission is to be the trusted global source of essential and advanced chemicals, empowering scientists and researchers to drive progress in science and industry.

Contact

Address: 3281 E Guasti Rd
Ontario, CA 91761, United States
Phone: (601) 213-4426
Email: info@benchchem.com

[Contact our Ph.D. Support Team for a compatibility check](#)