

Application Note: Optimizing Solvent Systems for Stille Couplings of Benzonitrile Stannanes

Author: BenchChem Technical Support Team. **Date:** April 2026

Compound of Interest

Compound Name: *Benzonitrile, 4-(tributylstannyl)-*

CAS No.: 79048-30-9

Cat. No.: B8519595

[Get Quote](#)

Part 1: Executive Summary & Mechanistic Rationale

The Challenge: Benzonitrile Stannanes

In drug discovery, the introduction of a benzonitrile motif via Stille cross-coupling is a critical transformation. However, (tributylstannyl)benzonitriles present a specific kinetic challenge compared to electron-rich stannanes (e.g., vinyl or thienyl stannanes).

- **Electronic Deactivation:** The cyano (-CN) group is strongly electron-withdrawing. In the standard Stille mechanism, the transmetallation step is nucleophilic attack of the stannane on the Pd(II) intermediate. Electron-poor stannanes are weaker nucleophiles, making transmetallation the rate-determining step (RDS).
- **Catalyst Poisoning:** The nitrile nitrogen has a lone pair capable of coordinating to Pd(II), potentially displacing labile ligands (like phosphines) and forming unreactive Pd(Ar)(X)(L)(NC-R) species, thereby arresting the catalytic cycle.

The Solution: Solvent-Driven Acceleration

The choice of solvent is not merely about solubility; it dictates the reaction mechanism.

- Non-polar solvents (Toluene): Favor a "neutral" pathway where ligand dissociation must precede transmetallation. High thermal energy (reflux) is required to drive the sluggish transmetallation of benzonitriles.
- Polar Aprotic Solvents (DMF, NMP): Accelerate the reaction by stabilizing the ionic intermediates of the oxidative addition and, critically, enabling the "Copper Effect" (if CuI is added), which bypasses the slow direct transmetallation.

Part 2: Mechanistic Visualization

The following diagram illustrates the divergent pathways dictated by solvent and additive choice.

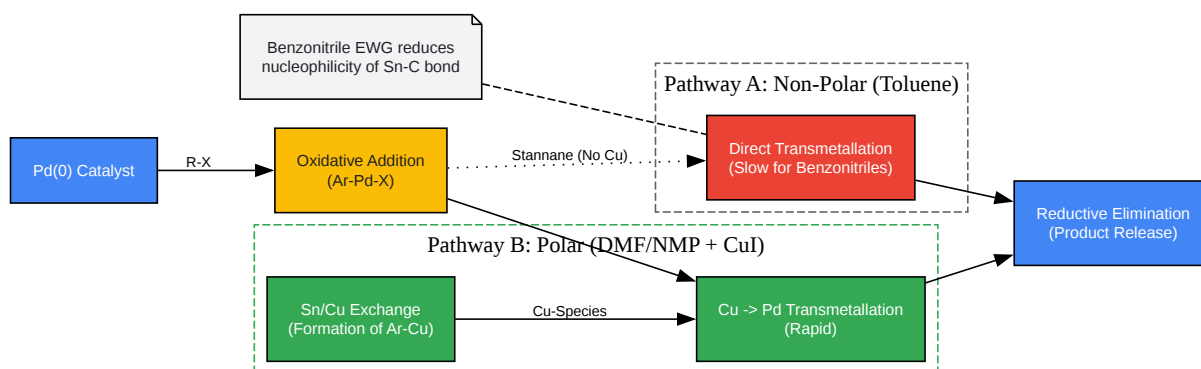

[Click to download full resolution via product page](#)

Figure 1: Mechanistic divergence. Pathway A (Red) is often rate-limited by the electron-poor nature of benzonitrile stannanes. Pathway B (Green) utilizes polar solvents and Copper(I) to switch mechanism, accelerating the reaction.

Part 3: Solvent Selection Matrix

Select your solvent system based on the thermal stability of your electrophile and the available equipment.

Solvent System	Role	Temp. Range	Suitability for Benzonitriles	Critical Notes
Toluene	Non-polar, Thermal driver	90°C - 110°C	Moderate. Requires high heat to overcome electronic deactivation.	Best for "Ligandless" conditions. Must be strictly anhydrous.
DMF / NMP	Polar Aprotic, Ligand stabilizer	60°C - 100°C	High. Essential if using the "Copper Effect" (CuI).	Stabilizes Pd(II) but can make catalyst removal harder. High boiling point makes workup tedious (requires aqueous wash).
1,4-Dioxane	Ethereal, Moderate Polarity	80°C - 100°C	Good. Balanced solubility profile.	Good compromise. Can be removed by rotovap (unlike DMF).
THF	Ethereal, Low boiling	60°C (Reflux)	Low. Generally insufficient thermal energy for hindered/deactivated stannanes.	Only use if substrate is thermally unstable.

Part 4: Experimental Protocols

Protocol A: The "Copper-Accelerated" Method (Recommended)

Best for: Rapid synthesis, difficult substrates, and ensuring high conversion of electron-poor stannanes.

Reagents:

- Aryl Halide (1.0 equiv)[1][2]
- 4-(Tributylstannyl)benzotrile (1.1 equiv)
- Catalyst: Pd(PPh₃)₄ (5 mol%) or PdCl₂(PPh₃)₂ (5 mol%)
- Promoter: CuI (10-20 mol%) - The "Liebeskind" additive [1]
- Solvent: Anhydrous DMF (0.1 - 0.2 M concentration)

Step-by-Step:

- Degassing (Critical): Place the solid reagents (Aryl halide, Stannane, CuI) in a reaction vial. Seal and purge with Argon/Nitrogen for 5 minutes. Note: Oxygen causes homocoupling of stannanes.
- Solvent Prep: Sparge anhydrous DMF with Argon for 15 minutes prior to use.
- Addition: Add DMF via syringe, followed by the Pd catalyst. (Adding catalyst last prevents premature oxidation in solution).
- Reaction: Heat to 80°C.
 - Observation: The reaction mixture often turns dark brown/black quickly.
 - Kinetics: Monitor by HPLC/LCMS at 1 hour. The CuI facilitates a Sn

Cu transmetallation, creating a more reactive organocopper species that transfers the benzotrile group to Pd rapidly.
- Workup (Fluoride Wash):
 - Dilute with EtOAc.[2][3]
 - Wash organic layer 3x with 5% LiCl (aq) (removes DMF) and 2x with Sat. KF (aq).[2][3][4][5]

- Why KF? Fluoride binds tin (Bu_3SnF is insoluble), precipitating it as a white solid for filtration.

Protocol B: The "Thermal Toluene" Method

Best for: Large scale scale-up where DMF removal is problematic, or if Copper contamination is a concern.

Reagents:

- Aryl Halide (1.0 equiv)[1][2]
- 4-(Tributylstannyl)benzotrile (1.2 equiv)
- Catalyst: $\text{Pd}(\text{PPh}_3)_4$ (5-10 mol%)
- Solvent: Anhydrous Toluene

Step-by-Step:

- Setup: Flame-dry a round-bottom flask equipped with a reflux condenser.
- Degassing: Combine reagents in Toluene. Freeze-pump-thaw (3 cycles) is ideal, or vigorous sparging with Argon for 20 mins.
- Reaction: Heat to Reflux (110°C).
 - Note: This requires higher temperatures than Protocol A because the electron-poor benzotrile stannane is a poor nucleophile.
- Monitoring: Reaction times are typically 12–24 hours.
- Scavenger Workup:
 - Cool to RT.
 - Add KF on Silica (approx 2g per mmol of stannane). Stir for 2 hours.

- Filter through a pad of Celite.[3][4] The tin byproducts remain trapped on the silica/fluoride matrix.

Part 5: Troubleshooting & Optimization

Decision Tree for Optimization:

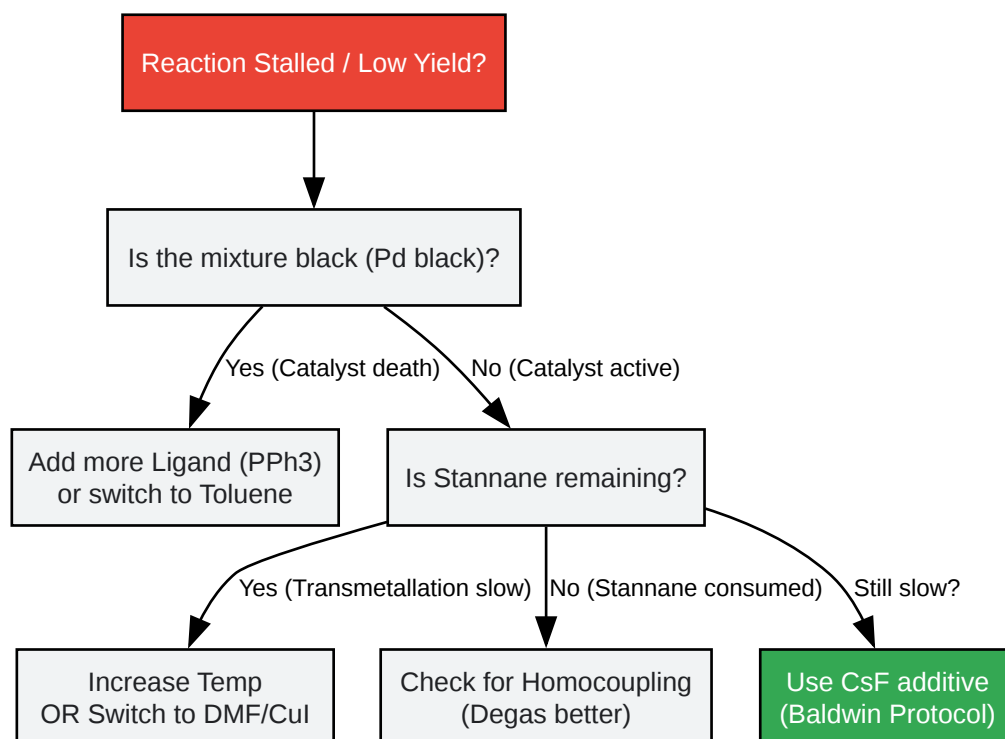

[Click to download full resolution via product page](#)

Figure 2: Troubleshooting logic for benzonitrile couplings.

Common Pitfalls

- "The Black Crash": If the reaction turns black and stops converting, your Pd has precipitated.
 - Fix: Benzonitriles can compete for ligation. Add 10-20% free PPh₃ to stabilize the catalyst in solution.
- Destannylation: In Toluene at high heat, the C-Sn bond can sometimes cleave (protodestannylation) if any moisture is present.

- Fix: Ensure strict anhydrous conditions or switch to the milder Protocol A (DMF/CuI) which runs at lower temperatures.

References

- Farina, V., & Krishnamurthy, V. (1998).^[6] "The Stille Reaction."^{[1][2][3][6][7][8][9][10][11][12][13][14]} Organic Reactions.^{[1][2][4][5][7][10][13][15]} (The definitive review on kinetics and mechanism).
- Farina, V., Kapadia, S., Krishnan, B., Wang, C., & Liebeskind, L. S. (1994). "On the nature of the 'copper effect' in the Stille cross-coupling." *Journal of Organic Chemistry*, 59(20), 5905-5911. (Establishes the CuI mechanism for polar solvents).
- Mee, S. P., Lee, V., & Baldwin, J. E. (2004).^{[10][15]} "Stille Coupling Made Easier - The Synergic Effect of Copper(I) Salts and the Fluoride Ion." *Angewandte Chemie International Edition*, 43(9), 1132-1136. (Protocol for CsF/CuI acceleration).
- Milstein, D., & Stille, J. K. (1978). "A general, selective, and facile method for ketone synthesis from acid chlorides and organotin compounds catalyzed by palladium." *Journal of the American Chemical Society*, 100(11), 3636-3638. (Foundational Stille paper).

Need Custom Synthesis?

BenchChem offers custom synthesis for rare earth carbides and specific isotopic labeling.

Email: info@benchchem.com or [Request Quote Online](#).

Sources

- 1. pdf.smolcule.com [pdf.smolcule.com]
- 2. organic-synthesis.com [organic-synthesis.com]
- 3. pdf.benchchem.com [pdf.benchchem.com]
- 4. chem.rochester.edu [chem.rochester.edu]
- 5. chemistry.msu.edu [chemistry.msu.edu]
- 6. pubs.acs.org [pubs.acs.org]

- [7. Stille reaction - Wikipedia \[en.wikipedia.org\]](#)
- [8. Copper-Catalyzed Stille Cross-Coupling Reaction and Application in the Synthesis of the Spliceostatin Core Structure - PMC \[pmc.ncbi.nlm.nih.gov\]](#)
- [9. uwindsor.ca \[uwindsor.ca\]](#)
- [10. Stille Coupling \[organic-chemistry.org\]](#)
- [11. application.wiley-vch.de \[application.wiley-vch.de\]](#)
- [12. organicreactions.org \[organicreactions.org\]](#)
- [13. scispace.com \[scispace.com\]](#)
- [14. researchgate.net \[researchgate.net\]](#)
- [15. Stille Coupling Made Easier - The Synergic Effect of Copper\(I\) Salts and the Fluoride Ion \[organic-chemistry.org\]](#)
- [To cite this document: BenchChem. \[Application Note: Optimizing Solvent Systems for Stille Couplings of Benzonitrile Stannanes\]. BenchChem, \[2026\]. \[Online PDF\]. Available at: \[https://www.benchchem.com/product/b8519595/docs#application-note-optimizing-solvent-systems-for-stille-couplings-of-benzonitrile-stannanes\]](#)

Disclaimer & Data Validity:

The information provided in this document is for Research Use Only (RUO) and is strictly not intended for diagnostic or therapeutic procedures. While BenchChem strives to provide accurate protocols, we make no warranties, express or implied, regarding the fitness of this product for every specific experimental setup.

Technical Support: The protocols provided are for reference purposes. Unsure if this reagent suits your experiment?

Need Industrial/Bulk Grade? [Request Custom Synthesis Quote](#)

BenchChem

Our mission is to be the trusted global source of essential and advanced chemicals, empowering scientists and researchers to drive progress in science and industry.

Contact

Address: 3281 E Guasti Rd
Ontario, CA 91761, United States
Phone: (601) 213-4426
Email: info@benchchem.com

[Contact our Ph.D. Support Team for a compatibility check](#)