

# polymorphic phase transitions of terbium fluoride

**Author:** BenchChem Technical Support Team. **Date:** April 2026

## Compound of Interest

Compound Name: *Terbium(III) fluoride*

CAS No.: 13708-63-9

Cat. No.: B085176

[Get Quote](#)

An In-depth Technical Guide to the Polymorphic Phase Transitions of Terbium Fluoride

## Authored by: A Senior Application Scientist

This guide provides a comprehensive technical overview of the polymorphic phase transitions of terbium (III) fluoride ( $TbF_3$ ). Designed for researchers, materials scientists, and professionals in drug development where fluoride compounds may be relevant, this document synthesizes crystallographic data with proven experimental methodologies. We will explore the structural characteristics of  $TbF_3$  polymorphs and the thermodynamic conditions that induce their transformation, grounded in authoritative scientific literature.

## Introduction: The Significance of Polymorphism in Terbium Fluoride

Polymorphism, the ability of a solid material to exist in more than one crystal structure, is a critical phenomenon in materials science.[1] These different crystalline forms, or polymorphs, can exhibit distinct physical and chemical properties, including solubility, stability, and optical behavior. Terbium (III) fluoride ( $TbF_3$ ), a white, powder-like inorganic compound, is a member of

the rare-earth fluoride ( $\text{REF}_3$ ) family and serves as a fascinating subject for studying polymorphic transitions.[2][3]

At ambient conditions,  $\text{TbF}_3$  adopts a stable orthorhombic crystal structure.[2][4] However, under the influence of external stimuli such as high pressure and high temperature, it can be induced to transform into a hexagonal phase.[5][6] Terbium fluoride is considered a boundary compound within the lanthanide trifluoride series, marking a shift in the relative stabilities of different crystal structures across the series.[4][7][8] Understanding these transitions is paramount for its application in fields such as optics, electronics, and the synthesis of specialized alloys and sensors.[2][9]

## The Crystalline Structures of Terbium Fluoride

Terbium fluoride primarily exists in two well-characterized polymorphic forms. The structural details are crucial as they dictate the material's macroscopic properties.

### Low-Temperature/Ambient Orthorhombic Phase ( $\beta\text{-YF}_3$ type)

This is the thermodynamically stable form of  $\text{TbF}_3$  at room temperature and atmospheric pressure.[2][4] Its structure is analogous to that of  $\beta$ -yttrium fluoride.

- Crystal System: Orthorhombic
- Space Group: Pnma
- Lattice Parameters:
  - $a = 0.651 \text{ nm}$ [2]
  - $b = 0.695 \text{ nm}$ [2]
  - $c = 0.438 \text{ nm}$ [2]

### High-Pressure/High-Temperature Hexagonal Phase ( $\text{LaF}_3$ type)

This phase is not stable at ambient conditions but can be induced by applying significant pressure or heat.<sup>[5][6]</sup> This structure is common among the lighter rare-earth trifluorides. The transition involves a rearrangement of the coordination environment around the terbium ion.

Property	Orthorhombic ( $\beta$ -YF <sub>3</sub> type) Phase	Hexagonal (LaF <sub>3</sub> type) Phase
Crystal System	Orthorhombic	Hexagonal / Trigonal
Common Name	$\beta$ -phase	tysonite-type
Stability	Ambient Temperature & Pressure	High Pressure / Temperature
Space Group	Pnma	P3c1 (for LaF <sub>3</sub> type)
Coordination No.	9	11

## Inducing Phase Transitions: Pressure and Temperature Effects

The transformation between the orthorhombic and hexagonal polymorphs is a function of pressure and temperature, representing a shift in the Gibbs free energy landscape of the system.

### Pressure-Induced Orthorhombic-to-Hexagonal Transition

At room temperature, applying hydrostatic pressure can force the more open orthorhombic structure to transform into the denser hexagonal phase.<sup>[5][6]</sup> This is a common phenomenon observed across several rare-earth fluorides from samarium to lutetium.<sup>[5][6]</sup>

- Transition Pressure for TbF<sub>3</sub>: The phase transition from orthorhombic to hexagonal occurs within the pressure range of 8.4–11.9 GPa.<sup>[5][6]</sup>
- Causality: This transition is driven by the system's tendency to minimize its volume under compression. The hexagonal structure represents a more efficient packing arrangement at elevated pressures. For the broader series of lanthanide trifluorides, the required transition

pressure generally increases as the ionic radius of the lanthanide decreases (and thus the initial cell volume is smaller).[5][6]

## Temperature-Induced Structural Changes

The high-temperature behavior of  $\text{TbF}_3$  is complex. While heavier rare-earth fluorides ( $\text{ErF}_3$  to  $\text{LuF}_3$ ) clearly transition from an orthorhombic to a trigonal structure upon heating,  $\text{TbF}_3$ 's behavior is less straightforward.[4]

- Observed Phenomena: X-ray absorption fine structure (XAFS) measurements have detected a structural variation occurring between  $785^\circ\text{C}$  and  $800^\circ\text{C}$ .[4]
- Irreversible Reactions: Studies suggest that heating  $\text{TbF}_3$  to approximately  $800^\circ\text{C}$  may induce irreversible structural changes or reactions, which requires careful consideration during high-temperature processing.[4]

The diagram below illustrates the general pathways for the polymorphic transitions in  $\text{TbF}_3$ .

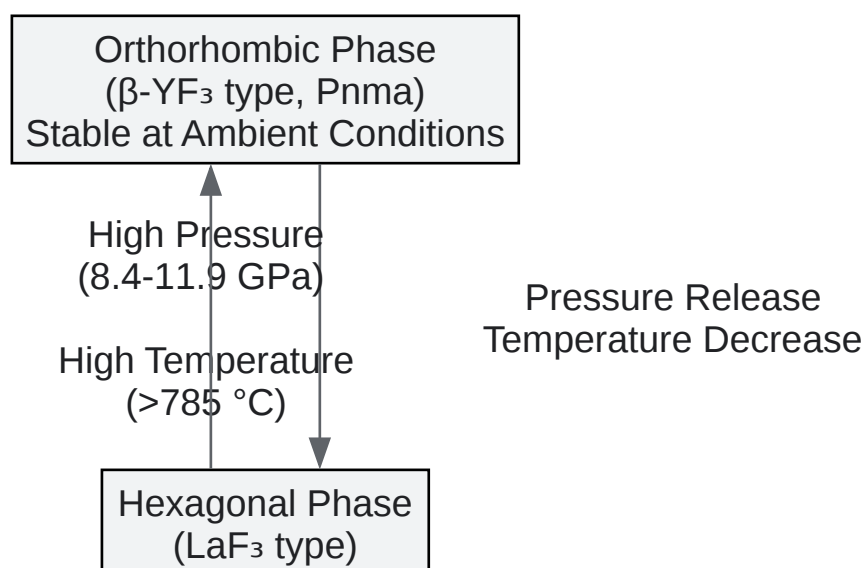

[Click to download full resolution via product page](#)

Caption: Phase transition pathways for Terbium Fluoride ( $\text{TbF}_3$ ).

# Experimental Protocols for Characterizing Phase Transitions

The investigation of polymorphic transitions requires a suite of analytical techniques. The choice of method is dictated by the need to obtain structural, thermodynamic, and spectroscopic information. Here, we detail the core, self-validating protocols.

## High-Resolution Powder X-ray Diffraction (XRD)

**Expertise & Rationale:** XRD is the definitive technique for identifying crystalline phases.[1] By measuring the diffraction of X-rays off the crystal lattice, we can determine the precise atomic arrangement, including the space group and lattice parameters, which serve as a unique fingerprint for each polymorph. In-situ measurements allow for the direct observation of structural changes as they occur under varying conditions.

Step-by-Step Protocol:

- Sample Preparation:
  - Finely grind the  $\text{TbF}_3$  sample to a homogenous powder to ensure random crystal orientation and minimize preferred orientation effects.
  - For ambient studies, mount the powder on a zero-background sample holder.
  - For in-situ high-pressure studies, load the powder into a diamond anvil cell (DAC), often with a pressure-transmitting medium (e.g., silicone oil or a noble gas) to ensure hydrostatic conditions.[5]
  - For in-situ high-temperature studies, press the powder into a pellet and place it on a high-temperature stage within the diffractometer. A non-reactive matrix like boron nitride (BN) can be used to dilute the sample and improve thermal stability.[4]
- Data Acquisition:
  - Use a diffractometer equipped with a monochromatic X-ray source (e.g.,  $\text{Cu K}\alpha$ ,  $\lambda = 1.54056 \text{ \AA}$ ).

- Scan a wide  $2\theta$  range (e.g., 10-90°) to capture all significant diffraction peaks.
- For in-situ studies, incrementally increase the pressure or temperature, allowing the system to equilibrate at each step before collecting a diffraction pattern.
- Data Analysis & Validation:
  - Perform phase identification by comparing the experimental diffraction pattern against reference patterns from crystallographic databases (e.g., ICDD).
  - Use Rietveld refinement to precisely determine the lattice parameters, space group, and atomic positions for each phase. A good refinement (low R-wp value) validates the structural model.
  - The disappearance of peaks corresponding to the orthorhombic phase and the emergence of peaks for the hexagonal phase unequivocally marks the transition.

## Differential Scanning Calorimetry (DSC)

Expertise & Rationale: DSC is a powerful thermal analysis technique that measures the heat flow associated with transitions in a material as a function of temperature.<sup>[10]</sup> It provides quantitative thermodynamic data, such as the transition temperature ( $T_t$ ) and the enthalpy of transition ( $\Delta H_t$ ). An endothermic peak on heating signifies the energy required to drive the transition from a lower-energy to a higher-energy polymorph.

Step-by-Step Protocol:

- Instrument Calibration: Calibrate the DSC instrument for temperature and enthalpy using certified reference materials (e.g., indium, tin) that have well-defined melting points and enthalpies of fusion.<sup>[11]</sup> This ensures the trustworthiness of the measurements.
- Sample Preparation:
  - Accurately weigh 5-10 mg of the  $TbF_3$  powder into a clean, inert sample pan (e.g., aluminum for sub-600°C studies, platinum or alumina for higher temperatures).<sup>[11]</sup>
  - Hermetically seal the pan to prevent any sample loss or interaction with the atmosphere.

- Prepare an identical empty, sealed pan to be used as a reference.
- Measurement:
  - Place the sample and reference pans into the DSC cell.
  - Heat the sample at a constant, controlled rate (e.g., 10 °C/min) under a purge of inert gas (e.g., nitrogen or argon) to create a stable thermal environment.
  - Record the differential heat flow between the sample and the reference as a function of temperature.
- Data Analysis & Validation:
  - Identify phase transitions as endothermic (or exothermic on cooling) peaks in the resulting thermogram.
  - The onset temperature of the peak is typically reported as the transition temperature.
  - Integrate the area of the peak to calculate the enthalpy of the transition ( $\Delta H_t$ ). The reproducibility of  $T_t$  and  $\Delta H_t$  over multiple runs validates the result.

## Raman Spectroscopy

Expertise & Rationale: Raman spectroscopy is a non-destructive technique that probes the vibrational modes of a crystal lattice.<sup>[12][13]</sup> Since each crystal structure has a unique set of allowed vibrational modes (phonons), a polymorphic transition will result in a distinct change in the Raman spectrum. This can manifest as the appearance or disappearance of peaks, shifts in peak positions, or the splitting of peaks, providing a sensitive indicator of changes in local symmetry.<sup>[14]</sup>

### Step-by-Step Protocol:

- Sample Preparation: Mount the  $TbF_3$  powder on a microscope slide or, for high-pressure studies, within a DAC.
- Data Acquisition:

- Focus a monochromatic laser onto the sample. Use a low laser power to avoid laser-induced heating, which could inadvertently trigger a phase transition.[13]
- Collect the inelastically scattered light using a high-resolution spectrometer.
- Record spectra at various controlled temperatures or pressures to monitor changes.
- Data Analysis & Validation:
  - Compare the spectra obtained before and after the transition point (as determined by XRD or DSC).
  - Assign observed Raman peaks to specific vibrational modes based on symmetry analysis (group theory) or comparison with theoretical calculations.
  - A clear, abrupt change in the number, position, or shape of the Raman bands serves as strong, independent validation of a structural phase transition.

The following diagram outlines a comprehensive workflow for characterizing polymorphic transitions.

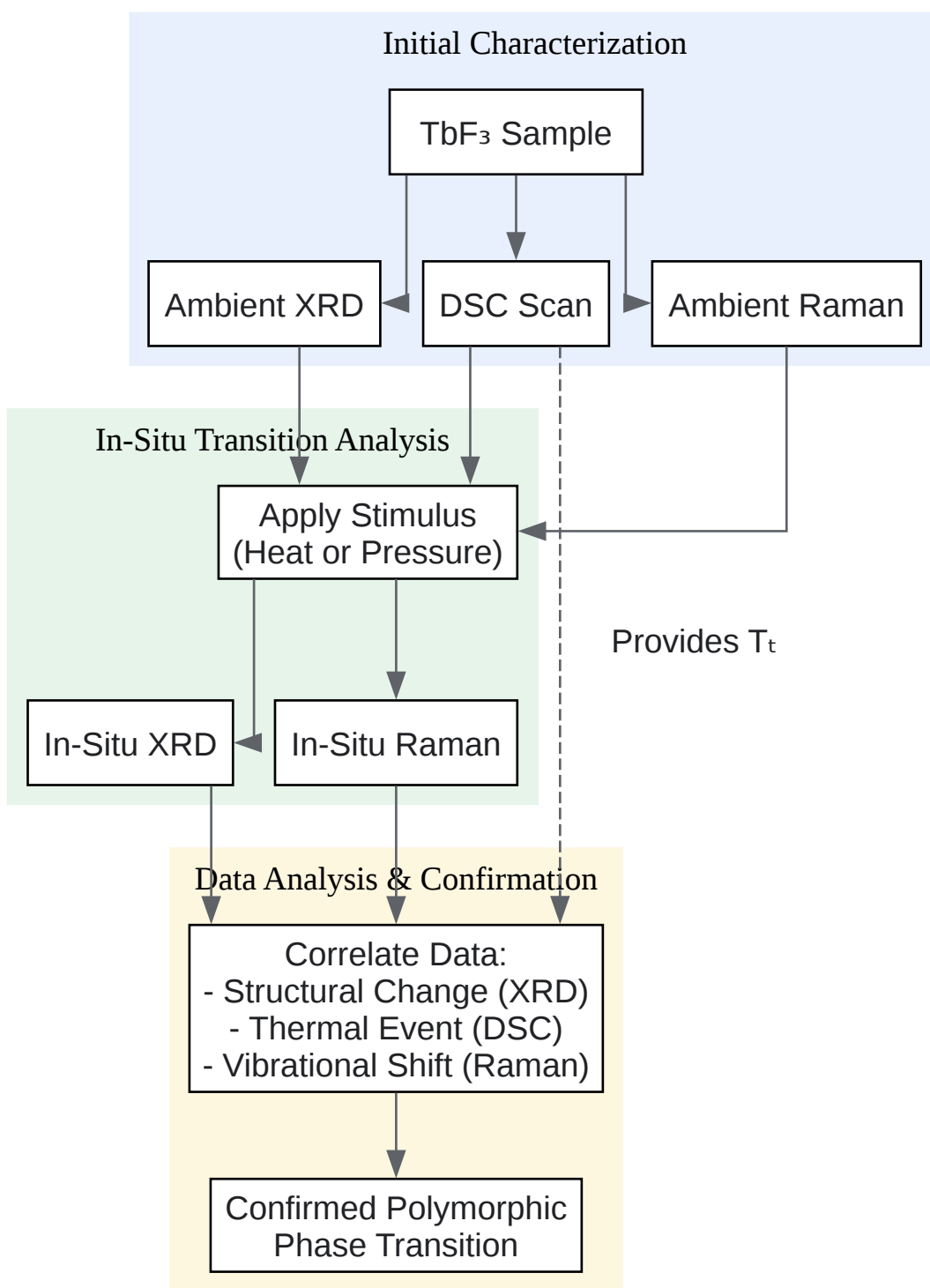

[Click to download full resolution via product page](#)

Caption: Experimental workflow for characterizing phase transitions.

## Conclusion and Future Directions

The polymorphic behavior of terbium fluoride, characterized by a stable orthorhombic phase at ambient conditions and a high-pressure hexagonal phase, is a cornerstone of its material properties. The transition between these forms, driven by pressure and temperature, has been rigorously defined through established analytical techniques. The protocols detailed herein—combining the structural certainty of XRD, the thermodynamic quantification of DSC, and the spectroscopic sensitivity of Raman—provide a robust framework for investigating these phenomena.

Future research should focus on further elucidating the complex high-temperature behavior of  $TbF_3$ , including the potential for intermediate phases or superionic conductivity, which has been hypothesized but not yet confirmed.[4] A deeper understanding of these transitions will enable the precise engineering of terbium fluoride-based materials for advanced applications in solid-state lighting, laser technology, and high-pressure sensing.

## References

- Grokipedia. **Terbium(III) fluoride**.
- KEK.
- ResearchGate. Orthorhombic-to-Hexagonal Phase Transition of REF 3 (RE = Sm to Lu and Y) under High Pressure.
- ACS Publications. Orthorhombic-to-Hexagonal Phase Transition of REF3 (RE = Sm to Lu and Y) under High Pressure | Inorganic Chemistry.
- OSTI.GOV. Morphotropic transitions in the rare-earth trifluoride series (Journal Article).
- ResearchGate. (PDF) Morphotropic transitions in the rare-earth trifluoride series.
- Terbium fluoride TbF.
- Rigaku. Evaluation of polymorphic forms by powder X-ray diffraction and thermal analysis methods.
- Differential Scanning Calorimetry Techniques: Applic
- TDX. Chapter 2: EXPERIMENTAL TECHNIQUES.
- Wikipedia. **Terbium(III) fluoride**.
- Uni Ulm. Differential Scanning Calorimetry – Instruction Notes.
- MDPI. Structural Phase Transition in (NH 4 )
- Journal of Materials Chemistry A (RSC Publishing). Direct observation of phase transitions between delta- and alpha-phase FAPbI<sub>3</sub> via defocused Raman spectroscopy.
- MDPI. Size Dependence of the Tetragonal to Orthorhombic Phase Transition of Ammonia Borane in Nanoconfinement.

### Need Custom Synthesis?

BenchChem offers custom synthesis for rare earth carbides and specific isotopic labeling.

Email: [info@benchchem.com](mailto:info@benchchem.com) or [Request Quote Online](#).

## Sources

- [1. resources.rigaku.com](https://resources.rigaku.com) [[resources.rigaku.com](https://resources.rigaku.com)]
- [2. grokipedia.com](https://grokipedia.com) [[grokipedia.com](https://grokipedia.com)]
- [3. Terbium\(III\) fluoride - Wikipedia](https://en.wikipedia.org) [[en.wikipedia.org](https://en.wikipedia.org)]
- [4. pfkek.jp](https://pfkek.jp) [[pfkek.jp](https://pfkek.jp)]
- [5. researchgate.net](https://researchgate.net) [[researchgate.net](https://researchgate.net)]
- [6. pubs.acs.org](https://pubs.acs.org) [[pubs.acs.org](https://pubs.acs.org)]
- [7. Morphotropic transitions in the rare-earth trifluoride series \(Journal Article\) | OSTI.GOV](#) [[osti.gov](https://osti.gov)]
- [8. researchgate.net](https://researchgate.net) [[researchgate.net](https://researchgate.net)]
- [9. download.s21i.co99.net](https://download.s21i.co99.net) [[download.s21i.co99.net](https://download.s21i.co99.net)]
- [10. Differential Scanning Calorimetry Techniques: Applications in Biology and Nanoscience - PMC](#) [[pmc.ncbi.nlm.nih.gov](https://pmc.ncbi.nlm.nih.gov)]
- [11. uni-ulm.de](https://uni-ulm.de) [[uni-ulm.de](https://uni-ulm.de)]
- [12. mdpi.com](https://mdpi.com) [[mdpi.com](https://mdpi.com)]
- [13. Direct observation of phase transitions between delta- and alpha-phase FAPbI<sub>3</sub> via defocused Raman spectroscopy - Journal of Materials Chemistry A \(RSC Publishing\)](#) [[pubs.rsc.org](https://pubs.rsc.org)]
- [14. Size Dependence of the Tetragonal to Orthorhombic Phase Transition of Ammonia Borane in Nanoconfinement | MDPI](#) [[mdpi.com](https://mdpi.com)]
- To cite this document: BenchChem. [polymorphic phase transitions of terbium fluoride]. BenchChem, [2026]. [Online PDF]. Available at: [<https://www.benchchem.com/product/b085176/docs#polymorphic-phase-transitions-of-terbium-fluoride>]

---

### Disclaimer & Data Validity:

The information provided in this document is for Research Use Only (RUO) and is strictly not intended for diagnostic or therapeutic procedures. While BenchChem strives to provide accurate protocols, we make no warranties, express or implied, regarding the fitness of this product for every specific experimental setup.

**Technical Support:** The protocols provided are for reference purposes. Unsure if this reagent suits your experiment?

**Need Industrial/Bulk Grade?** [Request Custom Synthesis Quote](#)

## BenchChem

Our mission is to be the trusted global source of essential and advanced chemicals, empowering scientists and researchers to drive progress in science and industry.

### Contact

Address: 3281 E Guasti Rd  
Ontario, CA 91761, United States  
Phone: (601) 213-4426  
Email: [info@benchchem.com](mailto:info@benchchem.com)

[Contact our Ph.D. Support Team for a compatibility check](#)