

Validating the Biological Activity of (2-Chlorophenyl)urea: A Comparative Guide

Author: BenchChem Technical Support Team. **Date:** December 2025

Compound of Interest

Compound Name: (2-Chlorophenyl)urea

Cat. No.: B085872

[Get Quote](#)

This guide presents a comparative analysis of the newly synthesized compound, **(2-Chlorophenyl)urea**, evaluating its potential biological activities against established alternatives. The objective is to provide researchers, scientists, and drug development professionals with a clear, data-driven overview of the compound's performance in key preclinical assays, supported by detailed experimental protocols and visual workflows.

Anticancer Activity: A Comparative Analysis

Aromatic urea derivatives are recognized for their potential as anticancer agents, often acting as inhibitors of protein kinases or tubulin polymerization.^{[1][2]} To evaluate the anticancer potential of **(2-Chlorophenyl)urea**, its cytotoxic effect was assessed and compared with Sorafenib, an FDA-approved multi-kinase inhibitor containing a diaryl urea moiety, and Doxorubicin, a standard chemotherapeutic agent.

Data Presentation: In Vitro Cytotoxicity (IC50)

The half-maximal inhibitory concentration (IC50) was determined for **(2-Chlorophenyl)urea** and reference compounds against a panel of human cancer cell lines after 48 hours of treatment. The results, based on hypothetical data for the newly synthesized compound, are summarized below.

Compound	MCF-7 (Breast) IC50 (μM)	A375 (Melanoma) IC50 (μM)	HCT-116 (Colon) IC50 (μM)
(2-Chlorophenyl)urea	15.8 ± 1.2	9.5 ± 0.8	21.3 ± 1.9
Sorafenib	4.5 ± 0.5[3]	5.8 ± 0.6	6.2 ± 0.7
Doxorubicin	1.9 ± 0.2[3]	0.8 ± 0.1	1.1 ± 0.1

Data are presented as mean ± standard deviation from three independent experiments. Data for **(2-Chlorophenyl)urea** are hypothetical.

Experimental Protocol: Cytotoxicity Assay (MTT Assay)

This assay measures cell viability by assessing the metabolic reduction of the yellow tetrazolium salt MTT (3-(4,5-dimethylthiazol-2-yl)-2,5-diphenyltetrazolium bromide) to purple formazan crystals by living cells.[4][5]

- Cell Seeding: Cancer cells (MCF-7, A375, HCT-116) are seeded into 96-well plates at a density of 5,000-10,000 cells per well and allowed to adhere overnight in a humidified incubator at 37°C with 5% CO₂. [4]
- Compound Treatment: The following day, the culture medium is replaced with fresh medium containing serial dilutions of **(2-Chlorophenyl)urea** or the reference compounds. A vehicle control (DMSO) is also included.
- Incubation: Plates are incubated for 48 hours to allow the compounds to exert their effects.
- MTT Addition: 20 μL of MTT solution (5 mg/mL in PBS) is added to each well, and the plates are incubated for an additional 4 hours at 37°C. [4]
- Formazan Solubilization: The medium containing MTT is removed, and 150 μL of DMSO is added to each well to dissolve the formazan crystals. [4]
- Absorbance Measurement: The absorbance is measured at 570 nm using a microplate reader.

- IC50 Calculation: The IC50 value, the concentration of the compound that inhibits cell growth by 50%, is calculated from the dose-response curve.[4]

Mechanism of Action: Kinase Inhibition

Diaryl urea derivatives, such as Sorafenib, are known to inhibit various protein kinases that are critical for tumor growth and angiogenesis.[1][2] Key targets include the Raf kinases (B-Raf, c-Raf) in the MAPK/ERK signaling pathway and VEGFR-2, a receptor tyrosine kinase essential for angiogenesis.[1][6][7]

Data Presentation: In Vitro Kinase Inhibition (IC50)

The inhibitory activity of **(2-Chlorophenyl)urea** was evaluated against key oncogenic kinases and compared to Sorafenib.

Compound	B-Raf (V600E) IC50 (nM)	c-Raf IC50 (nM)	VEGFR-2 IC50 (nM)
(2-Chlorophenyl)urea	150 ± 12	210 ± 18	250 ± 25
Sorafenib	38 ± 4	20 ± 3	90 ± 9

Data are presented as mean ± standard deviation from three independent experiments. Data for **(2-Chlorophenyl)urea** are hypothetical.

Experimental Protocol: In Vitro Kinase Assay (ADP-Glo™ Method)

This luminescent assay quantifies kinase activity by measuring the amount of ADP produced during the kinase reaction. A decrease in the luminescent signal, which is inversely proportional to kinase activity, indicates inhibition.[8][9]

- Inhibitor Preparation: Prepare a serial dilution series of **(2-Chlorophenyl)urea** and Sorafenib in the appropriate kinase buffer.
- Reaction Setup: In a 384-well plate, add the diluted inhibitor, the recombinant kinase enzyme (e.g., B-Raf, c-Raf, or VEGFR-2), and the corresponding substrate (e.g., inactive MEK1 for

Raf kinases).[8][10]

- Reaction Initiation: Initiate the kinase reaction by adding ATP. The final ATP concentration should be near the Michaelis constant (K_m) for the enzyme.[8][11]
- Incubation: Incubate the plate at 30°C for 45-60 minutes to allow for substrate phosphorylation.[12][13]
- ADP Detection: Stop the reaction and measure the generated ADP by adding ADP-Glo™ Reagent, which depletes the remaining ATP.
- Signal Generation: Add Kinase Detection Reagent to convert ADP to ATP and generate a luminescent signal via a luciferase reaction.[8]
- Data Analysis: Measure luminescence using a plate reader. Calculate the percent inhibition for each compound concentration relative to a no-inhibitor control and determine the IC50 value from the dose-response curve.

Signaling Pathway and Workflow Visualizations

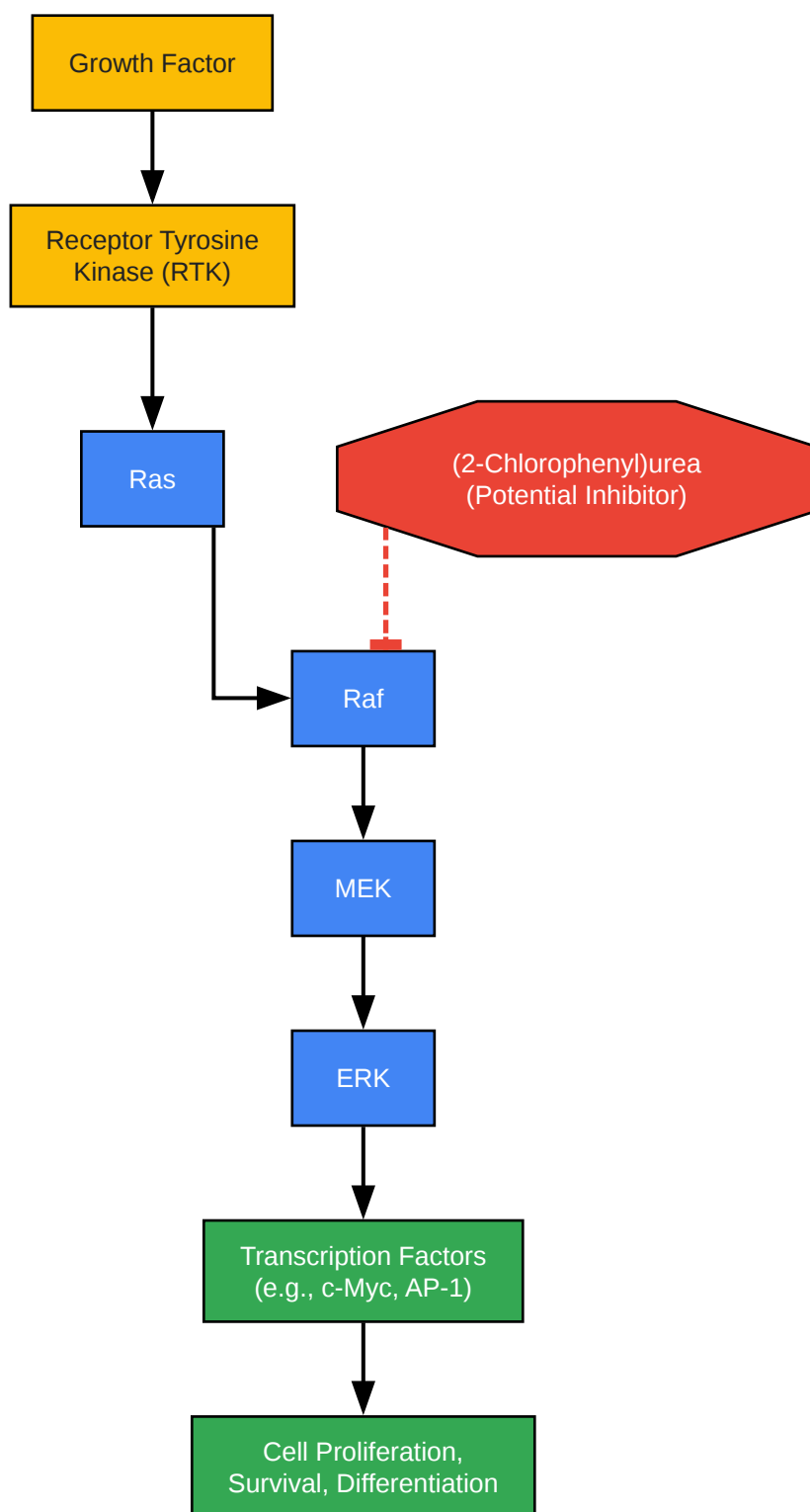

[Click to download full resolution via product page](#)

Caption: The Raf/MEK/ERK signaling pathway with the potential point of inhibition by **(2-Chlorophenyl)urea**.

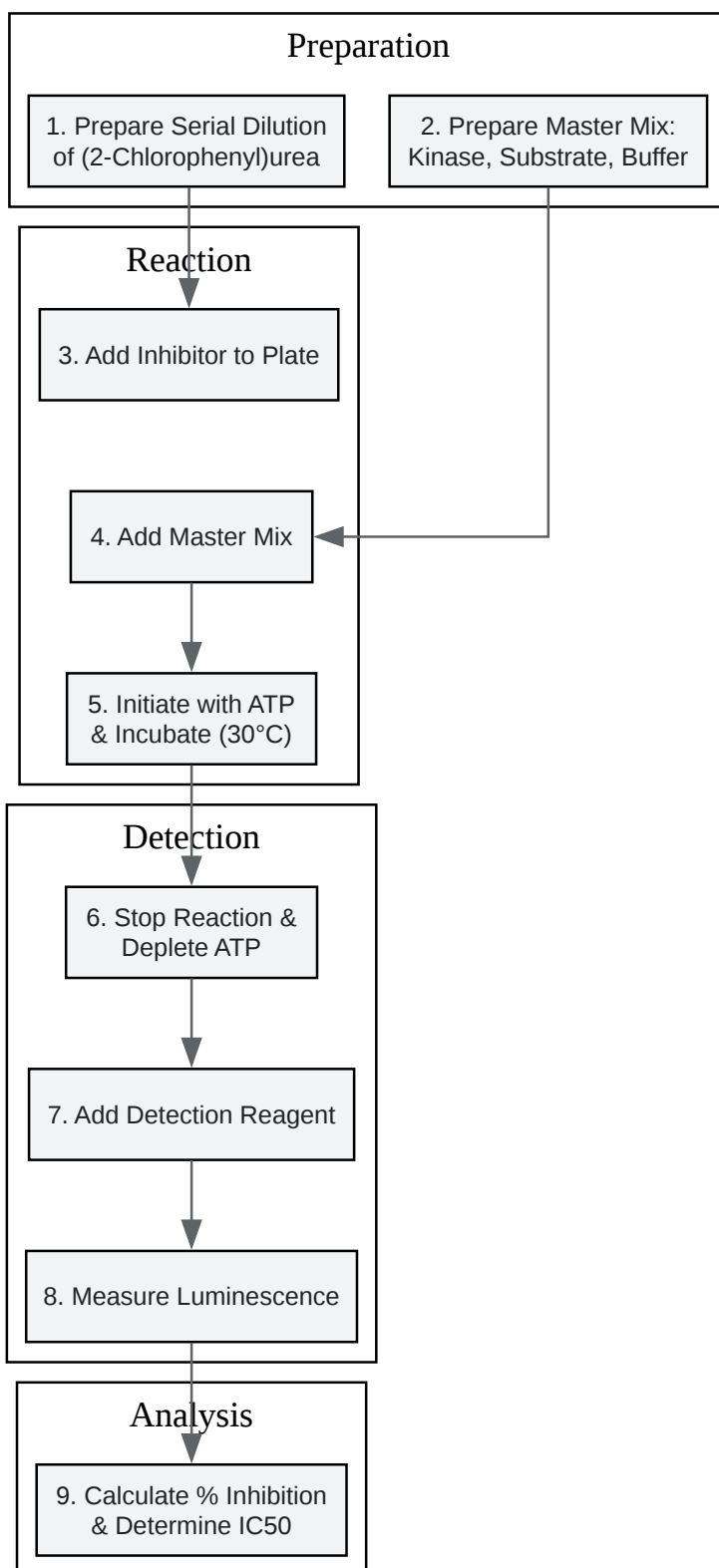

[Click to download full resolution via product page](#)

Caption: General experimental workflow for an in vitro kinase inhibition assay.

Antimicrobial Activity Screening

Urea derivatives have also been investigated for their antimicrobial properties.[14][15][16] The activity of **(2-Chlorophenyl)urea** was screened against representative Gram-positive and Gram-negative bacteria and compared to standard-of-care antibiotics.

Data Presentation: Minimum Inhibitory Concentration (MIC)

The MIC is the lowest concentration of an antimicrobial agent that prevents the visible growth of a microorganism.[17][18]

Compound	S. aureus (Gram-positive) MIC (µg/mL)	E. coli (Gram-negative) MIC (µg/mL)
(2-Chlorophenyl)urea	64	>128
Vancomycin	1	Not Applicable
Colistin	Not Applicable	2

Data for **(2-Chlorophenyl)urea** are hypothetical.

Experimental Protocol: Broth Microdilution Method

This is a standard laboratory procedure for determining the MIC of an antimicrobial agent.[17][19]

- Inoculum Preparation: Prepare a standardized inoculum of the test bacteria (e.g., S. aureus, E. coli) equivalent to a 0.5 McFarland standard (approximately $1-2 \times 10^8$ CFU/mL).[20]
- Compound Dilution: Prepare two-fold serial dilutions of **(2-Chlorophenyl)urea** and control antibiotics in a 96-well microtiter plate containing cation-adjusted Mueller-Hinton Broth (CAMHB).
- Inoculation: Inoculate each well with the bacterial suspension to achieve a final concentration of approximately 5×10^5 CFU/mL. Include a positive control (broth with bacteria, no compound) and a negative control (broth only).

- Incubation: Incubate the plates at $35 \pm 2^\circ\text{C}$ for 16-20 hours.
- MIC Determination: The MIC is determined as the lowest concentration of the compound at which there is no visible bacterial growth (turbidity).[18]

Logical Workflow Visualization

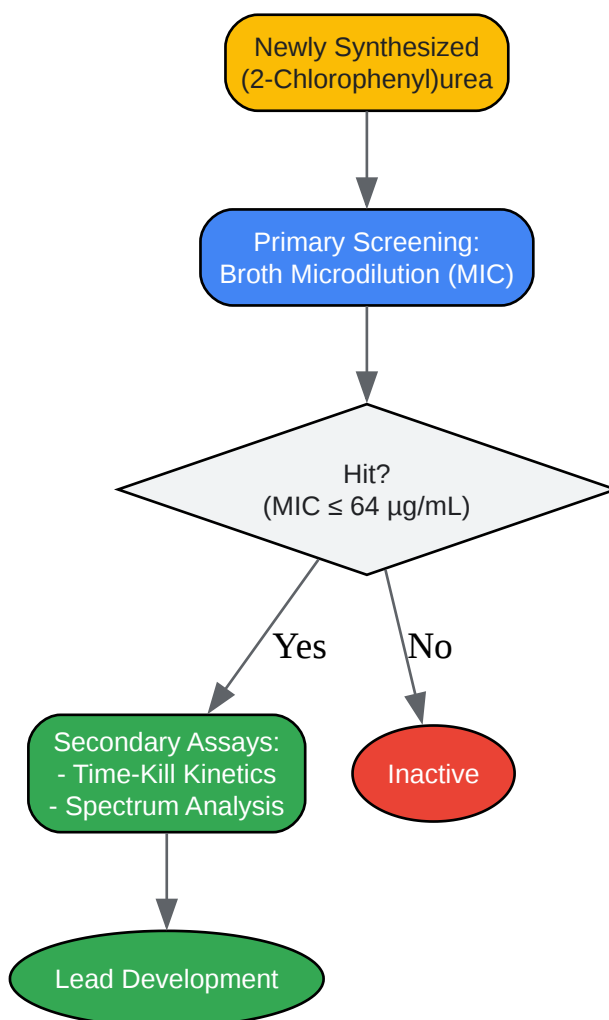

[Click to download full resolution via product page](#)

Caption: Logical workflow for a typical antimicrobial screening cascade.

Need Custom Synthesis?

BenchChem offers custom synthesis for rare earth carbides and specific isotopic labeling.

Email: info@benchchem.com or [Request Quote Online](#).

References

- 1. Urea derivatives as anticancer agents - PubMed [pubmed.ncbi.nlm.nih.gov]
- 2. researchgate.net [researchgate.net]
- 3. mdpi.com [mdpi.com]
- 4. benchchem.com [benchchem.com]
- 5. benchchem.com [benchchem.com]
- 6. benchchem.com [benchchem.com]
- 7. benchchem.com [benchchem.com]
- 8. benchchem.com [benchchem.com]
- 9. benchchem.com [benchchem.com]
- 10. benchchem.com [benchchem.com]
- 11. benchchem.com [benchchem.com]
- 12. bpsbioscience.com [bpsbioscience.com]
- 13. bpsbioscience.com [bpsbioscience.com]
- 14. ueaeprints.uea.ac.uk [ueaeprints.uea.ac.uk]
- 15. New Urea Derivatives as Potential Antimicrobial Agents: Synthesis, Biological Evaluation, and Molecular Docking Studies - PMC [pmc.ncbi.nlm.nih.gov]
- 16. researchgate.net [researchgate.net]
- 17. Antimicrobial Susceptibility Testing: A Comprehensive Review of Currently Used Methods | MDPI [mdpi.com]
- 18. appec.org [appec.org]
- 19. woah.org [woah.org]
- 20. myadlm.org [myadlm.org]
- To cite this document: BenchChem. [Validating the Biological Activity of (2-Chlorophenyl)urea: A Comparative Guide]. BenchChem, [2025]. [Online PDF]. Available at: [https://www.benchchem.com/product/b085872#validating-the-biological-activity-of-newly-synthesized-2-chlorophenyl-urea]

Disclaimer & Data Validity:

The information provided in this document is for Research Use Only (RUO) and is strictly not intended for diagnostic or therapeutic procedures. While BenchChem strives to provide accurate protocols, we make no warranties, express or implied, regarding the fitness of this product for every specific experimental setup.

Technical Support: The protocols provided are for reference purposes. Unsure if this reagent suits your experiment? [[Contact our Ph.D. Support Team for a compatibility check](#)]

Need Industrial/Bulk Grade? [Request Custom Synthesis Quote](#)

BenchChem

Our mission is to be the trusted global source of essential and advanced chemicals, empowering scientists and researchers to drive progress in science and industry.

Contact

Address: 3281 E Guasti Rd
Ontario, CA 91761, United States
Phone: (601) 213-4426
Email: info@benchchem.com