

# Cross-validation of Azapetine's effects in different vascular beds

**Author:** BenchChem Technical Support Team. **Date:** December 2025

## Compound of Interest

Compound Name: Azapetine

Cat. No.: B085885

[Get Quote](#)

## Azapetine: A Comparative Guide to its Vascular Effects

For Researchers, Scientists, and Drug Development Professionals

### Objective Comparison of Azapetine's Performance in Different Vascular Beds

This guide provides a comprehensive cross-validation of the vascular effects of **Azapetine**, a sympatholytic drug with vasodilatory properties. Due to the historical nature of much of the available research on **Azapetine**, this document synthesizes established knowledge with contemporary understanding of vascular pharmacology to offer a comparative perspective against other vasodilators. The information presented herein is intended to support further research and drug development efforts in the field of vascular medicine.

### Introduction to Azapetine

**Azapetine** is a non-selective alpha-adrenergic antagonist that was historically used in the management of peripheral vascular diseases.<sup>[1][2]</sup> Its primary mechanism of action involves the blockade of both  $\alpha_1$  and  $\alpha_2$ -adrenergic receptors, leading to the relaxation of vascular smooth muscle and subsequent vasodilation. This action counteracts the vasoconstrictive effects of endogenous catecholamines like norepinephrine and epinephrine. While its clinical

use has largely been superseded by more selective and newer agents, an understanding of its vascular effects provides valuable context for the development of novel vasodilators.

## Comparative Data on Vasodilator Effects

Due to the limited availability of recent, direct comparative studies on **Azapetine**, the following tables provide a synthesis of expected effects based on its mechanism as a non-selective alpha-blocker, in comparison to other classes of vasodilators.

Table 1: Comparison of Vasodilator Effects on Peripheral Vasculature

Vasodilator Class	Example Drug(s)	Primary Mechanism of Action	Effect on Arterioles	Effect on Veins	Key Clinical Applications
Non-selective $\alpha$ -blocker	Azapetine, Phentolamine	Blocks $\alpha$ 1 and $\alpha$ 2-adrenergic receptors.	Strong Dilation	Moderate Dilation	Peripheral Vascular Disease, Hypertensive Crises
Selective $\alpha$ 1-blocker	Prazosin, Doxazosin	Selectively blocks $\alpha$ 1-adrenergic receptors.	Strong Dilation	Minimal Dilation	Hypertension, Benign Prostatic Hyperplasia
Calcium Channel Blocker	Amlodipine, Nifedipine	Blocks L-type calcium channels in vascular smooth muscle.	Strong Dilation	Minimal Dilation	Hypertension, Angina
Nitrates	Nitroglycerin, Isosorbide Dinitrate	Increases nitric oxide (NO) production, leading to cGMP-mediated vasodilation.	Moderate Dilation	Strong Dilation	Angina, Heart Failure
ACE Inhibitors	Lisinopril, Ramipril	Inhibits Angiotensin-Converting Enzyme, reducing Angiotensin II levels.	Strong Dilation	Moderate Dilation	Hypertension, Heart Failure, Diabetic Nephropathy

Table 2: Cross-Validation of Effects in Different Vascular Beds (Predicted for **Azapetine**)

Vascular Bed	Predicted Effect of Azapetine (Non-selective $\alpha$ -blockade)	Comparative Vasodilators & Their Effects
Peripheral Arteries	Significant vasodilation, leading to increased blood flow.	Prazosin (selective $\alpha$ 1-blocker): Similar potent vasodilation. Nifedipine (CCB): Potent vasodilation.
Coronary Arteries	Moderate vasodilation. Potential for reflex tachycardia due to $\alpha$ 2-blockade, which could increase myocardial oxygen demand.	Nitroglycerin: Potent dilation of large epicardial arteries. Adenosine: Potent arteriolar dilation.
Cerebral Arteries	Likely causes vasodilation, but effects can be complex and may be influenced by systemic blood pressure changes.	Volatile Anesthetics (e.g., Isoflurane): Direct cerebral vasodilation. Ketamine: Increases cerebral blood flow.
Renal Arteries	Likely increases renal blood flow due to vasodilation.	ACE Inhibitors (e.g., Captopril): Increase renal blood flow and are protective in certain kidney diseases. Fenoldopam (Dopamine D1 agonist): Potent renal vasodilator.

## Signaling Pathways and Experimental Workflows

To visually represent the mechanisms and experimental procedures discussed, the following diagrams are provided in Graphviz DOT language.

### Signaling Pathway of Azapetine

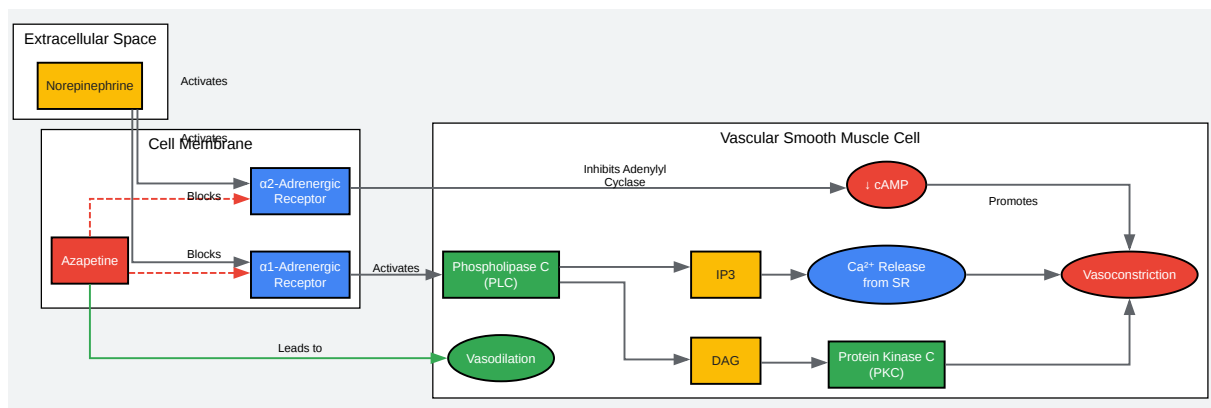

[Click to download full resolution via product page](#)

Caption: Signaling pathway of **Azapetine** in vascular smooth muscle.

## Experimental Workflow for Vascular Reactivity

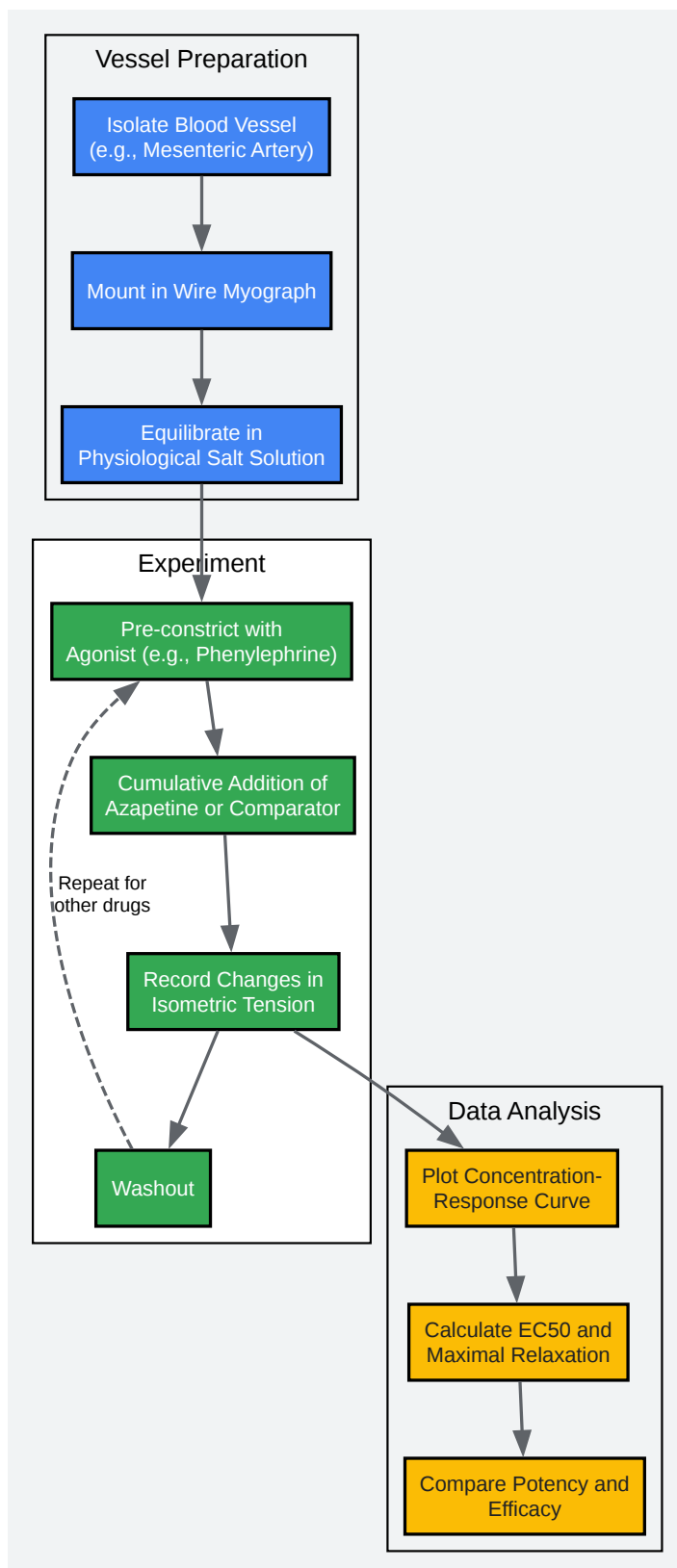

[Click to download full resolution via product page](#)

### Need Custom Synthesis?

BenchChem offers custom synthesis for rare earth carbides and specific isotopic labeling.

Email: [info@benchchem.com](mailto:info@benchchem.com) or [Request Quote Online](#).

## References

- 1. researchgate.net [researchgate.net]
- 2. Methods of renal blood flow measurement - PubMed [pubmed.ncbi.nlm.nih.gov]
- To cite this document: BenchChem. [Cross-validation of Azapetine's effects in different vascular beds]. BenchChem, [2025]. [Online PDF]. Available at: [https://www.benchchem.com/product/b085885#cross-validation-of-azapetine-s-effects-in-different-vascular-beds]

### Disclaimer & Data Validity:

The information provided in this document is for Research Use Only (RUO) and is strictly not intended for diagnostic or therapeutic procedures. While BenchChem strives to provide accurate protocols, we make no warranties, express or implied, regarding the fitness of this product for every specific experimental setup.

**Technical Support:** The protocols provided are for reference purposes. Unsure if this reagent suits your experiment? [[Contact our Ph.D. Support Team for a compatibility check](#)]

**Need Industrial/Bulk Grade?** [Request Custom Synthesis Quote](#)

## BenchChem

Our mission is to be the trusted global source of essential and advanced chemicals, empowering scientists and researchers to drive progress in science and industry.

### Contact

Address: 3281 E Guasti Rd

Ontario, CA 91761, United States

Phone: (601) 213-4426

Email: [info@benchchem.com](mailto:info@benchchem.com)