

Thermodynamic Stability & Medicinal Utility of 2,5-Difluoro Substitution Patterns

Author: BenchChem Technical Support Team. **Date:** April 2026

Compound of Interest

Compound Name: 4-Cyano-2,5-difluorobenzylamine

Cat. No.: B8494378

[Get Quote](#)

Content Type: Technical Whitepaper Audience: Medicinal Chemists, Computational Chemists, Drug Discovery Scientists Version: 1.0

Executive Summary

The 2,5-difluoro substitution pattern represents a privileged motif in modern drug design, offering a unique intersection of thermodynamic stability, metabolic resistance, and electronic modulation. Unlike the more common 2,4- or 2,6-difluoro patterns, the 2,5-motif exploits the para-relationship between the two fluorine atoms (relative to each other) to minimize dipolar penalties while maximizing quadrupole interactions. This guide analyzes the physicochemical drivers behind this pattern's success and provides actionable protocols for its integration into lead optimization campaigns.

Part 1: Theoretical Underpinnings & Electronic Landscape

The "Para-Difluoro" Anomaly

To understand the 2,5-difluoro pattern on a substituted phenyl ring (R-Ph-F

), one must analyze the intrinsic thermodynamics of the difluorobenzene core. In a 2,5-substituted system, the fluorine atoms are located at positions 2 and 5 relative to the primary substituent (

). Geometrically, these fluorines are para to each other.

Thermodynamic Stability Hierarchy (Intrinsic Energy): Calculated heats of formation (

) and relative energies reveal the following stability order for difluorobenzene isomers:

- 1,3-Difluorobenzene (meta): Most stable (ΔH_f° = -10.5 kcal/mol). The dipoles are opposed but not cancelling, and there is minimal steric repulsion.
- 1,2-Difluorobenzene (ortho): Less stable (ΔH_f° = -10.0 kcal/mol) due to lone-pair repulsion (dipole-dipole repulsion) between adjacent fluorines.
- 1,4-Difluorobenzene (para): Comparable to ortho (ΔH_f° = -10.0 kcal/mol).

Implication for 2,5-Substitution: The 2,5-pattern imposes a para-relationship between the fluorines. While this is not the global thermodynamic minimum (which would be meta), it provides a critical advantage: Symmetry-Driven Dipole Cancellation.

Electronic Vectors and "Polar Hydrophobicity"

The 2,5-difluoro motif creates a distinct electrostatic face compared to its isomers.

- Dipole Moment (μ):
(μ = 0.0 D): The vectors of the two fluorine atoms in a 2,5-pattern (para to each other) largely cancel the vector component perpendicular to the C2-C5 axis. This results in a lower net dipole compared to 2,3- or 3,4-patterns.
- Quadrupole Moment (Q):
(Q = 1.0): The 2,5-pattern significantly enhances the quadrupole moment perpendicular to the aromatic ring. This increases the strength of

-stacking interactions with aromatic amino acid residues (Phe, Tyr, Trp) in the binding pocket.

Table 1: Comparative Electronic Properties of Difluoro-Substituted Phenyl Rings

Property	2,5-Difluoro (R-Ph)	2,4-Difluoro (R-Ph)	2,6-Difluoro (R-Ph)
F-F Relationship	Para	Meta	Meta
Net Dipole ()	Moderate (Vector along C1-C4)	High (Vectors additive)	Low/Moderate (Vectors opposed)
Electronic Effect on R	Ortho-withdrawing / Meta-withdrawing	Ortho/Para-withdrawing	Double Ortho-withdrawing
Metabolic Block	Blocks C2 (ortho) and C5 (meta)	Blocks C2 (ortho) and C4 (para)	Blocks C2/C6 (both ortho)
Lipophilicity (LogD)	High (Polar Hydrophobicity)	Moderate	Moderate

Part 2: Conformational Thermodynamics & Binding Affinity

In drug design, "stability" often refers to the Free Energy of Binding (

). The 2,5-difluoro pattern enhances this via conformational locking.

The "Fluorine Lock" Effect

The fluorine atom at the 2-position (ortho to the scaffold connection) restricts rotation around the phenyl-scaffold bond via two mechanisms:

- **Steric Clashing:** The van der Waals radius of F (1.47 Å) creates a barrier to rotation against adjacent carbonyls or amides.
- **Electrostatic Locking:** An attractive interaction between the highly electronegative F and an electropositive atom (e.g., Amide N-H or C-H) can lock the molecule into a bioactive conformation, reducing the entropic penalty (

) upon binding.

Visualization: Electronic & Conformational Vectors

The following diagram illustrates the vector summation and potential steric clashes for the 2,5-pattern compared to the 2,4-pattern.

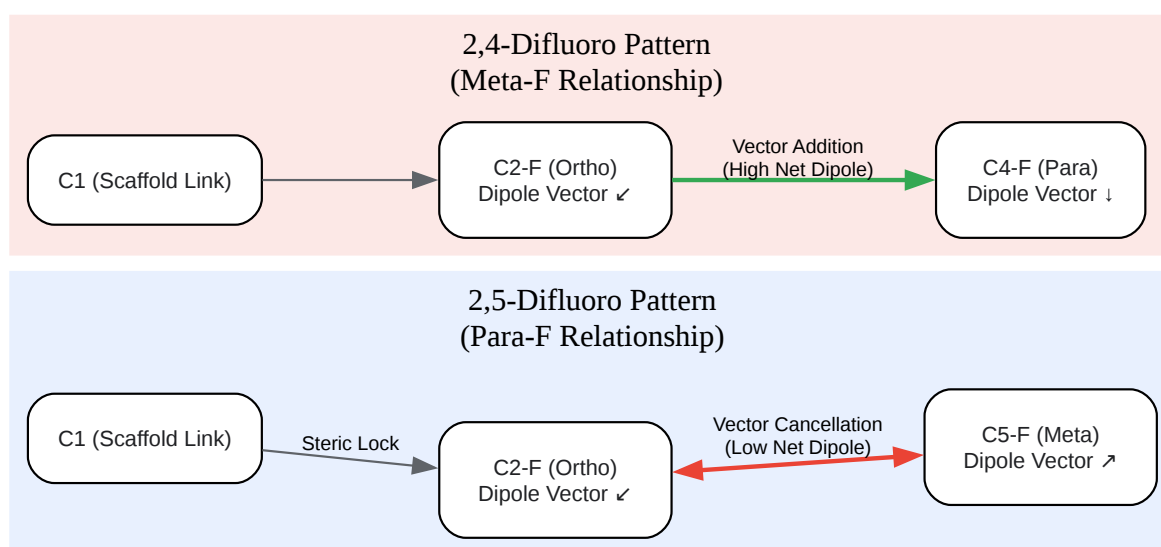

[Click to download full resolution via product page](#)

Caption: Vector analysis showing the partial dipole cancellation in the 2,5-motif (left) versus the additive dipole enhancement in the 2,4-motif (right), influencing membrane permeability and solubility.

Part 3: Metabolic Stability (Kinetic Thermodynamics)

The primary utility of the 2,5-difluoro pattern is the thermodynamic barrier to oxidation.

Blocking Metabolic Soft Spots

Cytochrome P450 enzymes typically attack electron-rich aromatic rings at the para-position relative to an electron-donating substituent, or at unsubstituted ortho positions.

- C-H Bond Energy: ~98 kcal/mol.
- C-F Bond Energy: ~116 kcal/mol.

Replacing a C-H bond with a C-F bond increases the activation energy (

) for the radical abstraction step in CYP450 catalysis to a point where the reaction is kinetically forbidden under physiological conditions.

The 2,5-Advantage

- vs. 2,4-Difluoro: The 2,4-pattern leaves the C5 position open. If the drug binds in a pocket where C5 is exposed to the heme iron, it remains a metabolic liability.
- vs. 2,6-Difluoro: The 2,6-pattern blocks both ortho positions but leaves the para (C4) and meta (C3, C5) positions open.
- The 2,5-Solution: This pattern blocks the critical C2 (ortho) and C5 (meta) positions. Crucially, C5 is often the site of metabolism for aniline derivatives. By blocking C5, the molecule forces the enzyme to attack the sterically hindered C3 or C4 positions, or the deactivated C6 position.

Part 4: Experimental Protocols

Protocol: Comparative Metabolic Stability Assay

To validate the thermodynamic stability of the 2,5-pattern against enzymatic degradation, use the following microsomal stability protocol.

Materials:

- Pooled Human Liver Microsomes (HLM) (20 mg/mL).
- NADPH Regenerating System (1.3 mM NADP⁺, 3.3 mM glucose-6-phosphate, 0.4 U/mL G6PDH).
- Test Compounds: 2,5-difluoro analog vs. non-fluorinated and 2,4-difluoro matched pairs.

Workflow:

- Incubation: Prepare 1 μM test compound in phosphate buffer (pH 7.4) with 0.5 mg/mL HLM.
- Initiation: Pre-incubate at 37°C for 5 min. Initiate reaction by adding NADPH system.
- Sampling: Aliquot 50 μL at T=0, 5, 15, 30, and 60 min into cold acetonitrile (containing internal standard) to quench.
- Analysis: Centrifuge (4000 rpm, 20 min). Analyze supernatant via LC-MS/MS.
- Calculation: Plot $\ln(\% \text{ remaining})$ vs. time.

Protocol: Regioselective Synthesis (SnAr)

Synthesizing the 2,5-difluoro core often involves Nucleophilic Aromatic Substitution (SnAr) on 2,4,5-trifluoronitrobenzene or similar precursors. The 2,5-pattern directs nucleophiles to specific positions based on solvent polarity.

Decision Logic for Synthesis:

- Non-polar solvents (Toluene): Favor ortho-substitution (relative to Nitro) due to H-bonding stabilization of the transition state.
- Polar Aprotic solvents (DMSO/DMF): Favor para-substitution due to charge separation stabilization.

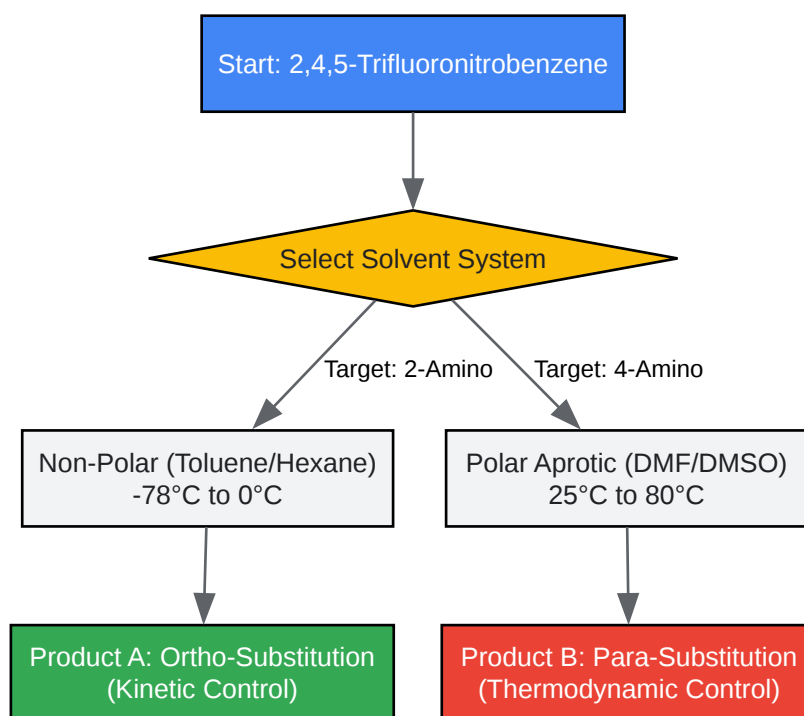

[Click to download full resolution via product page](#)

Caption: Regioselective control in synthesizing 2,5-difluoro precursors. Solvent polarity dictates the thermodynamic vs. kinetic product ratio.

Part 5: Case Studies in Drug Development

Dabrafenib (BRAF Inhibitor)

- Challenge: The initial lead suffered from rapid oxidative metabolism at the phenyl ring.
- Optimization: A "Fluorine Scan" was conducted.[1]
 - Monofluoro: Insufficient metabolic protection.[1]
 - 2,6-Difluoro:[2] Blocked metabolism but introduced steric clash with the binding pocket, reducing potency.
 - 2,5-Difluoro:[3][4] Successfully blocked the metabolic soft spot (C5) while maintaining an optimal dihedral angle for binding. The 2,5-pattern was critical for balancing metabolic stability (

) with binding affinity (

).

Gefitinib (EGFR Inhibitor)

- Mechanism: The 3-chloro-4-fluoroaniline moiety is a classic example of halogen substitution. While not strictly 2,5-difluoro, the principle of using a 3,4-dihalo pattern (electronically similar to 2,5 in terms of deactivation) lowers the HOMO energy of the aniline, preventing oxidation.
- Relevance: Recent analogs have explored the 2,5-difluoro-4-bromo pattern to further tune the quadrupole moment for specific mutant EGFR pockets.

References

- Comparison of Difluorobenzene Isomer Reactivity. BenchChem Technical Guides. (2025). [Link](#)
- An experimental and theoretical study of spin-spin coupling constants for 1,2-, 1,3-, and 1,4-difluorobenzene. Journal of Molecular Structure. (2010). [Link](#)
- Molecular Quadrupole Moments for the Series of Fluoro- and Chlorobenzenes. The Journal of Physical Chemistry. (1996). [Link](#)
- Metabolic Stability of Fluorinated Small Molecules. ChemRxiv. (2023). [Link](#)
- NIST Chemistry WebBook: 2,4-Difluoroaniline Thermochemistry. NIST Standard Reference Data. (2025). [Link](#)

Need Custom Synthesis?

BenchChem offers custom synthesis for rare earth carbides and specific isotopic labeling.

Email: info@benchchem.com or [Request Quote Online](#).

Sources

- [1. m.youtube.com \[m.youtube.com\]](https://m.youtube.com)

- [2. Phase Transitions Equilibria of Five Dichlorinated Substituted Benzenes | MDPI \[mdpi.com\]](#)
- [3. researchgate.net \[researchgate.net\]](#)
- [4. 2,5-Difluoroaniline | C6H5F2N | CID 67775 - PubChem \[pubchem.ncbi.nlm.nih.gov\]](#)
- To cite this document: BenchChem. [Thermodynamic Stability & Medicinal Utility of 2,5-Difluoro Substitution Patterns]. BenchChem, [2026]. [Online PDF]. Available at: [\[https://www.benchchem.com/product/b8494378/docs#thermodynamic-stability-medicinal-utility-of-2-5-difluoro-substitution-patterns\]](https://www.benchchem.com/product/b8494378/docs#thermodynamic-stability-medicinal-utility-of-2-5-difluoro-substitution-patterns)

Disclaimer & Data Validity:

The information provided in this document is for Research Use Only (RUO) and is strictly not intended for diagnostic or therapeutic procedures. While BenchChem strives to provide accurate protocols, we make no warranties, express or implied, regarding the fitness of this product for every specific experimental setup.

Technical Support: The protocols provided are for reference purposes. Unsure if this reagent suits your experiment?

Need Industrial/Bulk Grade? [Request Custom Synthesis Quote](#)

BenchChem

Our mission is to be the trusted global source of essential and advanced chemicals, empowering scientists and researchers to drive progress in science and industry.

Contact

Address: 3281 E Guasti Rd
Ontario, CA 91761, United States
Phone: (601) 213-4426
Email: info@benchchem.com

[Contact our Ph.D. Support Team for a compatibility check](#)

