

common side reactions and byproducts with (-)-DIP-Chloride

Author: BenchChem Technical Support Team. **Date:** April 2026

Compound of Interest

Compound Name: (-)-DIP-Chloride

Cat. No.: B8487921

[Get Quote](#)

Technical Support Center: (-)-DIP-Chloride

Welcome to the technical support center for (-)-DIP-Chloride. This resource is designed for researchers, scientists, and drug development professionals to provide troubleshooting guidance and frequently asked questions regarding the use of this versatile chiral reducing agent.

Frequently Asked Questions (FAQs)

Q1: What is (-)-DIP-Chloride and what is its primary application?

(-)-DIP-Chloride (B-chlorodiisopinocampheylborane) is a highly selective chiral reducing agent. Its principal application is the asymmetric reduction of prochiral ketones to their corresponding optically active secondary alcohols with high enantiomeric excess.^[1] It is particularly effective for the reduction of aryl alkyl ketones, α -hindered ketones, and perfluoroalkyl ketones.^[2]

Q2: What is the reaction mechanism for the reduction of ketones with (-)-DIP-Chloride?

The reduction occurs through a transfer hydrogenation mechanism. The carbonyl oxygen of the ketone coordinates to the Lewis acidic boron atom of the (-)-DIP-Chloride. This is followed by

the transfer of a hydride from one of the isopinocampheyl ligands to the carbonyl carbon via a six-membered boat-like transition state. Subsequent workup liberates the chiral alcohol.[3][4]

Q3: What are the main advantages of using (-)-DIP-Chloride?

The primary advantage of (-)-DIP-Chloride is its ability to achieve high levels of enantioselectivity in the reduction of a wide range of ketones.[5][6] It is a more reactive and better Lewis acid than other borane reagents like Alpine-Borane.[7]

Q4: What are the common side reactions and byproducts associated with (-)-DIP-Chloride?

The most common issue is the decomposition of the reagent due to its high sensitivity to moisture and air. This leads to a loss of activity and lower yields. Upon reaction, the isopinocampheyl group is eliminated as α -pinene. Incomplete reactions or decomposition can lead to a mixture of the desired alcohol, unreacted ketone, and borane byproducts, which can complicate purification.

Q5: How should (-)-DIP-Chloride be handled and stored?

Due to its sensitivity to moisture and air, (-)-DIP-Chloride must be handled under a dry, inert atmosphere (e.g., nitrogen or argon). It should be stored in a tightly sealed container in a cool, dry place. Solutions of the reagent are typically supplied in anhydrous solvents.

Troubleshooting Guide

Issue 1: Low or No Reaction Conversion

Possible Cause	Troubleshooting Step
Degraded Reagent	The most common cause of low yield is the degradation of (-)-DIP-Chloride due to exposure to air and moisture. It is crucial to use a fresh bottle or a properly stored reagent. If in doubt, titrate the reagent to determine its molarity before use.
Insufficient Reagent	Ensure at least a stoichiometric amount of the reagent is used. For challenging substrates, a slight excess may be required.
Low Reaction Temperature	While many reactions proceed well at -25 °C, some less reactive ketones may require a higher temperature. Monitor the reaction by TLC or GC to gauge progress.
Incompatible Solvent	Ethereal solvents like diethyl ether or tetrahydrofuran (THF) are commonly used. Ensure the solvent is anhydrous.

Issue 2: Low Enantioselectivity (ee)

Possible Cause	Troubleshooting Step
Incorrect Reagent Enantiomer	Ensure you are using the correct enantiomer of DIP-Chloride to obtain the desired product stereochemistry. (-)-DIP-Chloride typically affords (S)-alcohols from aryl alkyl ketones.[4]
Reaction Temperature Too High	Higher temperatures can sometimes erode enantioselectivity. Running the reaction at a lower temperature (e.g., -40 °C or -78 °C) may improve the ee.
Substrate Not Ideal	Unhindered prochiral dialkyl ketones are known to give poor enantioselectivity with (-)-DIP-Chloride.[5]
Moisture Contamination	Traces of water can react with the reagent, leading to non-selective reduction pathways. Ensure all glassware, solvents, and starting materials are scrupulously dry.

Issue 3: Difficult Product Purification

Possible Cause	Troubleshooting Step
Borane Byproducts	The standard workup with diethanolamine is designed to complex with the boron-containing byproducts, forming a precipitate that can be filtered off. Ensure sufficient diethanolamine is used.
Emulsion during Workup	If an emulsion forms during the aqueous workup, addition of brine or filtration through a pad of Celite can help to break it.
Product Volatility	If the product alcohol is volatile, care should be taken during solvent removal steps to avoid its loss.

Data Presentation

Table 1: Asymmetric Reduction of Representative Ketones with (-)-DIP-Chloride

Ketone	Product	Reaction Time (h)	Temperature (°C)	Yield (%)	ee (%)
Acetophenone	(S)-1-Phenylethanol	3	-25	92	96
2,2,2-Trifluoroacetophenone	(S)-2,2,2-Trifluoro-1-phenylethanol	72	25	90	90
1-Naphthyl trifluoromethyl ketone	(S)-1-(1-Naphthyl)-2,2,2-trifluoroethanol	120	25	85	78
Cyclohexyl trifluoromethyl ketone	(S)-1-Cyclohexyl-2,2,2-trifluoroethanol	12	25	75	87
Methyl 2-acetylbenzoate	(S)-3-Methylphthalide	-	-25	87	97

Data compiled from multiple sources.^{[2][5]} Conditions and results may vary based on specific experimental parameters.

Experimental Protocols

Key Experiment: Asymmetric Reduction of Acetophenone

This protocol describes a general procedure for the asymmetric reduction of acetophenone to (S)-1-phenylethanol using (-)-DIP-Chloride.

Materials:

- (-)-DIP-Chloride (solution in THF or as a solid)
- Acetophenone
- Anhydrous diethyl ether or THF
- Diethanolamine
- Anhydrous magnesium sulfate or sodium sulfate
- Standard laboratory glassware (oven-dried)
- Inert atmosphere setup (nitrogen or argon)

Procedure:

- **Reaction Setup:** Under an inert atmosphere, a solution of (-)-DIP-Chloride (1.1 equivalents) in anhydrous diethyl ether is cooled to -25 °C in a cryocool or a dry ice/acetone bath.
- **Substrate Addition:** Acetophenone (1.0 equivalent) is added dropwise to the stirred solution of (-)-DIP-Chloride.
- **Reaction Monitoring:** The reaction is stirred at -25 °C and monitored by thin-layer chromatography (TLC) or gas chromatography (GC) until the acetophenone is consumed (typically 2-4 hours).
- **Workup:**
 - The reaction is quenched by the slow addition of diethanolamine (3.0 equivalents).
 - The mixture is allowed to warm to room temperature and stirred for 30 minutes. A white precipitate of the diethanolamine-boron complex will form.

- The solid is removed by filtration through a pad of Celite, and the filter cake is washed with diethyl ether.
- The combined filtrate is washed sequentially with water and brine.
- Purification:
 - The organic layer is dried over anhydrous magnesium sulfate, filtered, and the solvent is removed under reduced pressure.
 - The crude product can be purified by flash column chromatography on silica gel (e.g., using a hexane/ethyl acetate gradient) to yield pure (S)-1-phenylethanol.
- Analysis: The enantiomeric excess of the product is determined by chiral GC or HPLC analysis.

Visualizations

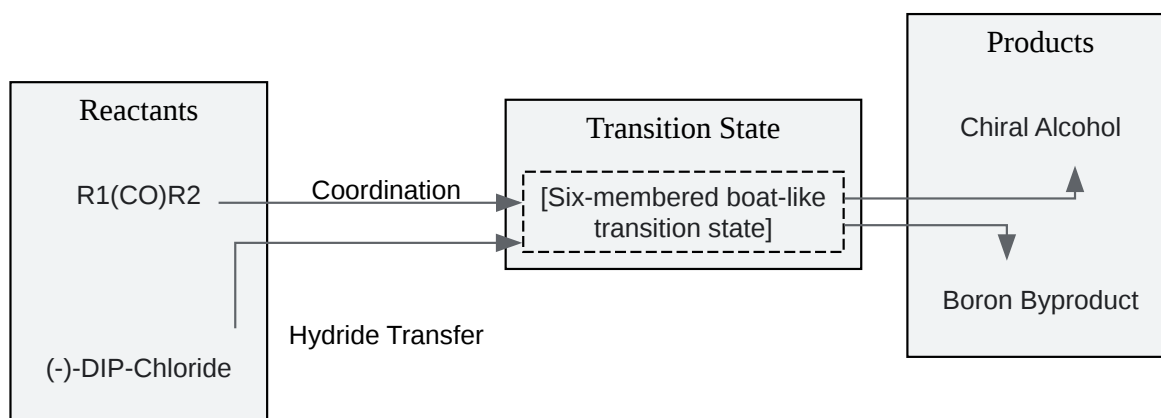

[Click to download full resolution via product page](#)

Caption: Reaction mechanism of ketone reduction by (-)-DIP-Chloride.

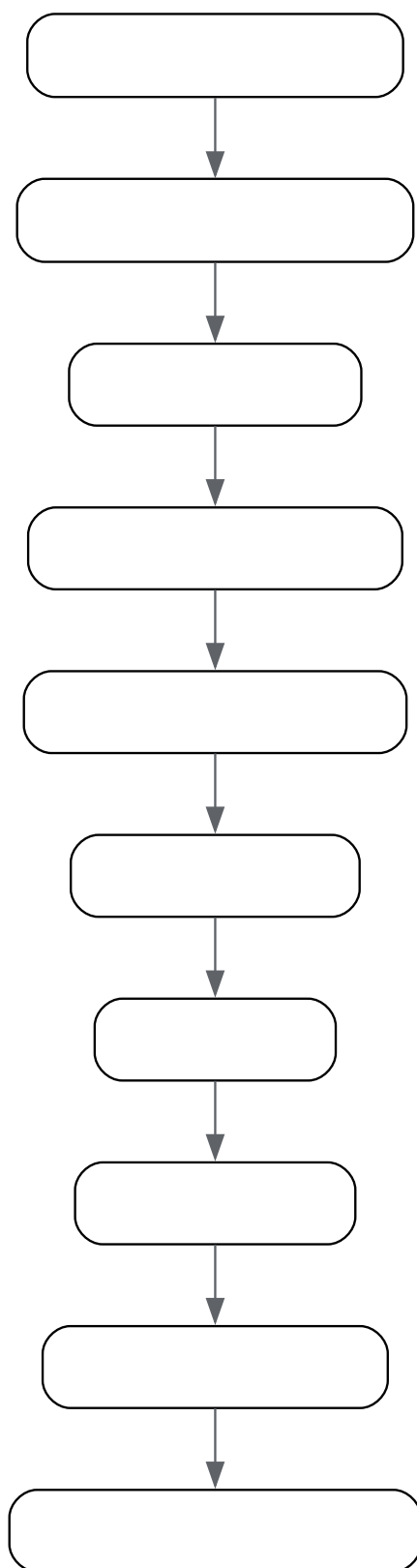

[Click to download full resolution via product page](#)

Caption: General experimental workflow for asymmetric ketone reduction.

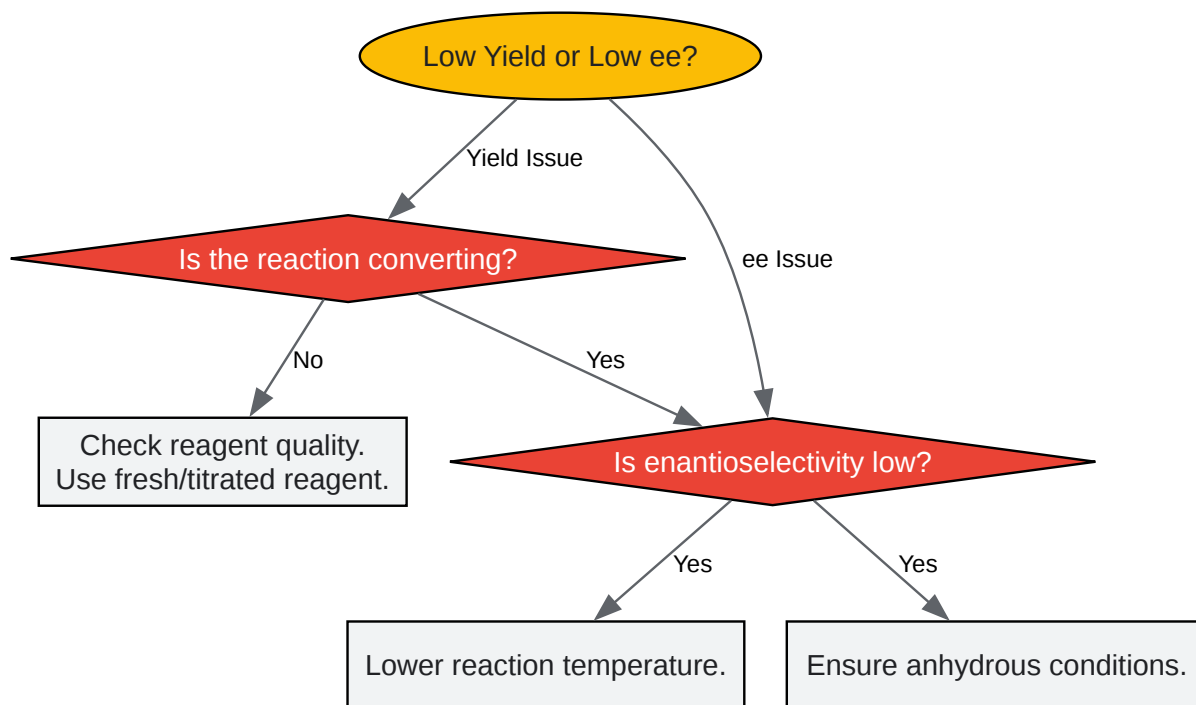

[Click to download full resolution via product page](#)

Caption: Troubleshooting decision tree for common issues.

Need Custom Synthesis?

BenchChem offers custom synthesis for rare earth carbides and specific isotopic labeling.

Email: info@benchchem.com or [Request Quote Online](#).

References

- [1. benchchem.com \[benchchem.com\]](https://www.benchchem.com)
- [2. apps.dtic.mil \[apps.dtic.mil\]](https://apps.dtic.mil)
- [3. Stoichiometric Boron Reagents - Wordpress \[reagents.acsgcipr.org\]](https://reagents.acsgcipr.org)
- [4. uwindsor.ca \[uwindsor.ca\]](https://www.uwindsor.ca)
- [5. researchgate.net \[researchgate.net\]](https://www.researchgate.net)

- [6. Selective reductions. 59. Effective intramolecular asymmetric reductions of alpha-, beta-, and gamma-keto acids with diisopinocampheylborane and intermolecular asymmetric reductions of the corresponding esters with B-chlorodiisopinocampheylborane - PubMed \[pubmed.ncbi.nlm.nih.gov\]](#)
- [7. ccc.chem.pitt.edu \[ccc.chem.pitt.edu\]](#)
- To cite this document: BenchChem. [common side reactions and byproducts with (-)DIP-Chloride]. BenchChem, [2026]. [Online PDF]. Available at: [\[https://www.benchchem.com/product/b8487921/docs#common-side-reactions-and-byproducts-with-dip-chloride\]](https://www.benchchem.com/product/b8487921/docs#common-side-reactions-and-byproducts-with-dip-chloride)

Disclaimer & Data Validity:

The information provided in this document is for Research Use Only (RUO) and is strictly not intended for diagnostic or therapeutic procedures. While BenchChem strives to provide accurate protocols, we make no warranties, express or implied, regarding the fitness of this product for every specific experimental setup.

Technical Support: The protocols provided are for reference purposes. Unsure if this reagent suits your experiment?

Need Industrial/Bulk Grade? [Request Custom Synthesis Quote](#)

BenchChem

Our mission is to be the trusted global source of essential and advanced chemicals, empowering scientists and researchers to drive progress in science and industry.

Contact

Address: 3281 E Guasti Rd
Ontario, CA 91761, United States
Phone: (601) 213-4426
Email: info@benchchem.com

[Contact our Ph.D. Support Team for a compatibility check](#)

