

# Advanced Application Note: Oxazolidinone-Directed Nazarov Cyclization Mechanism and Protocols

**Author:** BenchChem Technical Support Team. **Date:** April 2026

## Compound of Interest

Compound Name: Oxazolidine hydrochloride

Cat. No.: B8482011

[Get Quote](#)

## Introduction to Oxazolidinone-Directed Electrocyclizations

The Nazarov cyclization is a powerful  $4\pi$  electrocyclic reaction that converts cross-conjugated divinyl ketones into highly substituted cyclopentenones. While the reaction inherently controls relative stereochemistry through the conservation of orbital symmetry (conrotatory ring closure), achieving absolute stereocontrol—particularly for the synthesis of multiple contiguous quaternary stereocenters—has historically been a formidable challenge in drug development and natural product synthesis.

The integration of chiral oxazolidinone (Ox) auxiliaries into the Nazarov precursor has revolutionized this landscape. Acting as a remarkably effective chiral activating group, the oxazolidinone enables the torquoselective cyclization of sterically congested substrates under mild conditions. As a Senior Application Scientist, understanding the mechanistic departure of this reaction from classical auxiliary models is critical for optimizing yields, predicting stereochemical outcomes, and scaling up the synthesis of complex  $sp^3$ -rich scaffolds.

# Mechanistic Paradigm Shift: Beyond the Evans Model

Most applications of chiral oxazolidinone auxiliaries (e.g., the Evans model) rely on a common set of stereocontrol principles: the auxiliary is forced into a specific, coplanar conformation with the prochiral substrate, and the reaction occurs at the stereoheterotopic face that is not sterically blocked.

However, the oxazolidinone-directed Nazarov cyclization operates via a fundamentally different mechanism<sup>[1]</sup>:

- **Non-Coplanar Transition States:** Density Functional Theory (DFT) calculations reveal that during the transition state of the  $4\pi$  electrocyclic ring closure, the oxazolidinone ring and the cyclizing pentadienyl cation are distorted from coplanarity.
- **Allylic Strain over Face-Shielding:** The stereocontrol is driven entirely by allylic strain rather than coplanar face-shielding.
- **Dual Conformer Convergence:** The transition state can adopt two distinct conformations of similar energy: a syn-conformer (oxazolidinone carbonyl oriented toward the OH of the pentadienyl cation) and an anti-conformer (oriented away). Surprisingly, both conformations induce the same sense of torquoselectivity. The conrotatory mode leading to the C5- $\alpha$  epimer is heavily disfavored due to high levels of allylic strain between the oxazolidinone substituent and adjacent groups on the pentadienyl cation.
- **Intermediate Charge Stabilization:** Post-cyclization, the oxazolidinone acts as a charge-stabilizing group for the intermediate oxyallyl cation. This stabilization suppresses undesired [1,2]-sigmatropic shifts (Wagner–Meerwein rearrangements) and facilitates the regioselective and stereoselective trapping of nucleophiles.

## Quantitative Assessment of Stereocontrol

The table below summarizes the mechanistic and thermodynamic distinctions between classical oxazolidinone applications and the oxazolidinone-directed Nazarov cyclization.

Parameter	Conventional Evans Model	Oxazolidinone-Directed Nazarov
Stereocontrol Basis	Coplanar face-shielding	Allylic strain (Non-coplanar)
Active Conformations	Single (Syn or Anti)	Dual (Syn and Anti converge)
Torquoselectivity Preference	N/A (Face selection)	3–5 kcal/mol preference for C5- $\beta$ epimer
Intermediate Stabilization	N/A	Suppresses Wagner-Meerwein shifts
Typical Acid Promoters	TiCl <sub>4</sub> , Dialkylaluminum chloride	MeSO <sub>3</sub> H (2–10 eq), BF <sub>3</sub> ·OEt <sub>2</sub>

## Mechanistic Visualization

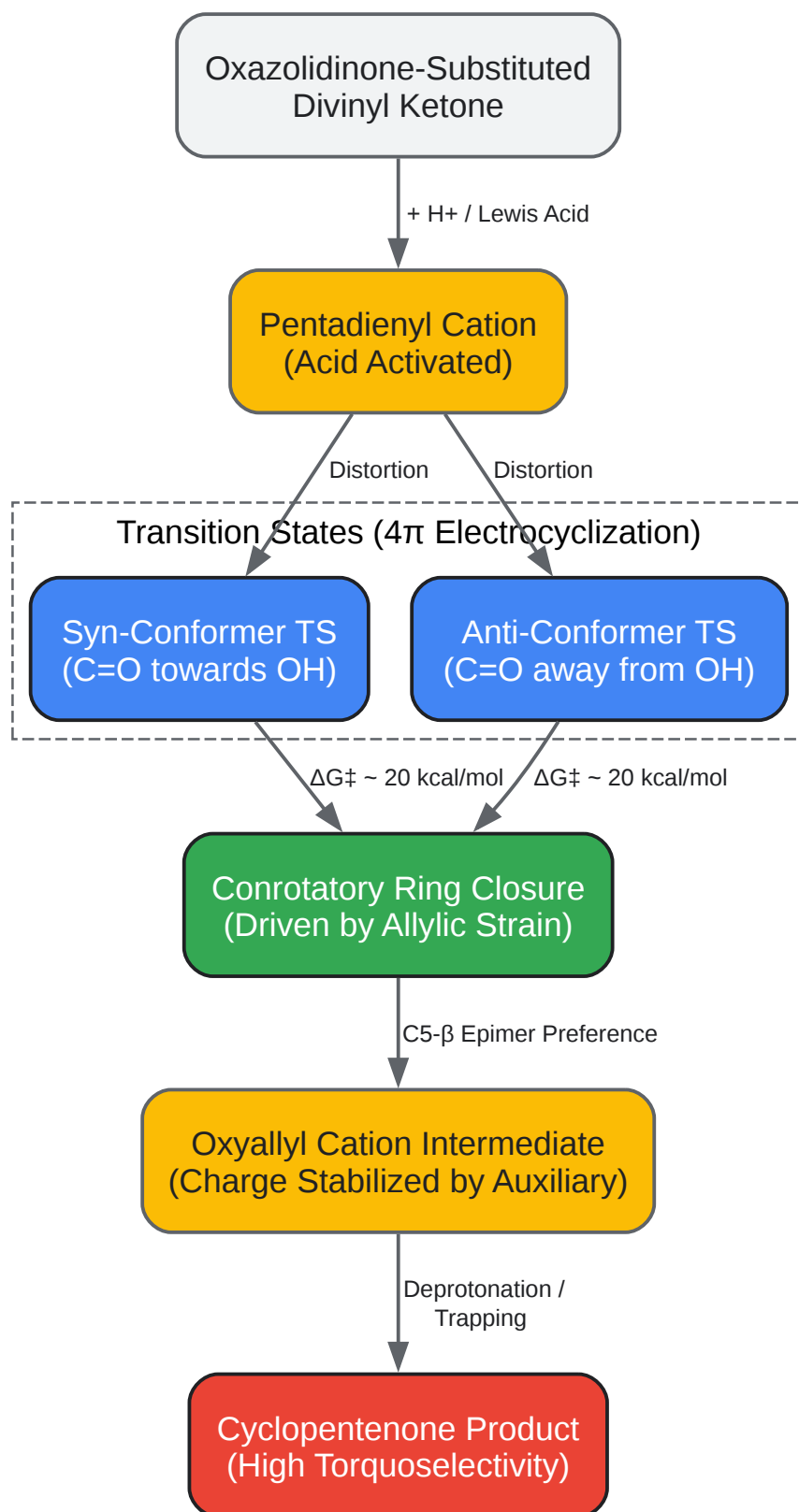

[Click to download full resolution via product page](#)

Mechanistic pathway of the oxazolidinone-directed Nazarov cyclization.

## Validated Experimental Protocols

The following self-validating protocol details the synthesis of multi-quaternary stereocenter cyclopentanoids from oxazolidinone-activated divinyl ketones.

### Phase 1: Torquoselective Nazarov Cyclization

Note: The precursor divinyl ketone is typically accessed via the carbometalation of Oxynamides or through Pd-catalyzed carbonylative Stille couplings[2].

- **Substrate Preparation:** In an oven-dried Schlenk flask under an argon atmosphere, dissolve the oxazolidinone-substituted divinyl ketone (1.0 mmol) in anhydrous dichloromethane (DCM, 10 mL).
- **Acid Activation:** Cool the reaction mixture to 0 °C using an ice bath. Dropwise, add methanesulfonic acid (MeSO<sub>3</sub>H, 2.0 to 10.0 equivalents, depending on the steric congestion of the substrate).
  - **Causality:** The strong Brønsted acid rapidly protonates the cross-conjugated dienone, generating the highly reactive pentadienyl cation required for the 4π electrocyclization.
- **Electrocyclization:** Allow the reaction to warm to room temperature and stir for 2–12 hours. Monitor the consumption of the starting material via TLC.
  - **Causality:** Prolonged stirring at room temperature provides the thermal energy required to overcome the ~20 kcal/mol activation barrier. During this phase, the oxazolidinone auxiliary distorts out of coplanarity to minimize allylic strain, driving the torquoselective conrotatory closure toward the C5-β epimer[1].
- **Quenching:** Once complete, quench the reaction by slowly pouring the mixture into an ice-cold saturated aqueous solution of NaHCO<sub>3</sub> (20 mL).
  - **Causality:** Rapid, cold neutralization prevents undesired epimerization or thermodynamic degradation of the newly formed, highly substituted cyclopentenone.
- **Extraction & Purification:** Extract the aqueous layer with DCM (3 × 15 mL). Wash the combined organic layers with brine, dry over anhydrous Na<sub>2</sub>SO<sub>4</sub>, and concentrate in vacuo.

Purify the crude product via flash column chromatography (silica gel, EtOAc/Hexanes gradient).

## Phase 2: Auxiliary Cleavage (Recovery of Cyclopentanoid)

To utilize the synthesized cyclopentanoid in downstream drug development, the oxazolidinone auxiliary must be removed without disrupting the newly established quaternary stereocenters.

- Preparation: Dissolve the purified oxazolidinone-bearing cyclopentanoid (0.5 mmol) in anhydrous THF (5 mL) and cool to  $-78\text{ }^{\circ}\text{C}$  under an argon atmosphere.
- Reductive Cleavage: Freshly prepare a solution of lithium naphthalenide (LiNph, 3.0 equivalents) in THF. Add the LiNph solution dropwise to the reaction mixture until a persistent dark green color is observed.
  - Causality: LiNph acts as a powerful single-electron reducing agent. It selectively cleaves the N–C bond of the auxiliary via a radical anion intermediate, leaving the sterically hindered all-carbon quaternary stereocenters intact.
- Quenching & Recovery: Quench the reaction with saturated aqueous  $\text{NH}_4\text{Cl}$  (5 mL) at  $-78\text{ }^{\circ}\text{C}$ , then allow the mixture to warm to room temperature. Extract with ethyl acetate ( $3 \times 10\text{ mL}$ ), dry over  $\text{Na}_2\text{SO}_4$ , and concentrate. The chiral oxazolidinone auxiliary can be recovered during the final chromatographic purification of the target cyclopentanol.

## References

- Opposing Auxiliary Conformations Produce the Same Torquoselectivity in an Oxazolidinone-Directed Nazarov Cyclization | Journal of the American Chemical Society [\[\[Link\]](#)
- Asymmetric synthesis of multiple quaternary stereocentre-containing cyclopentyls by oxazolidinone-promoted Nazarov cyclizations | Chemical Science [\[\[Link\]](#)
- Improved Yields with Added Copper(I) Salts in Carbonylative Stille Couplings of Sterically Hindered Vinylstannanes | The Journal of Organic Chemistry [\[\[Link\]](#)

### Need Custom Synthesis?

BenchChem offers custom synthesis for rare earth carbides and specific isotopic labeling.

Email: [info@benchchem.com](mailto:info@benchchem.com) or [Request Quote Online](#).

## Sources

- [1. pubs.acs.org \[pubs.acs.org\]](https://pubs.acs.org)
- [2. pubs.acs.org \[pubs.acs.org\]](https://pubs.acs.org)
- To cite this document: BenchChem. [Advanced Application Note: Oxazolidinone-Directed Nazarov Cyclization Mechanism and Protocols]. BenchChem, [2026]. [Online PDF]. Available at: [<https://www.benchchem.com/product/b8482011/docs#advanced-application-note-oxazolidinone-directed-nazarov-cyclization-mechanism-and-protocols>]

### Disclaimer & Data Validity:

The information provided in this document is for Research Use Only (RUO) and is strictly not intended for diagnostic or therapeutic procedures. While BenchChem strives to provide accurate protocols, we make no warranties, express or implied, regarding the fitness of this product for every specific experimental setup.

**Technical Support:** The protocols provided are for reference purposes. Unsure if this reagent suits your experiment?

**Need Industrial/Bulk Grade?** [Request Custom Synthesis Quote](#)

## BenchChem

Our mission is to be the trusted global source of essential and advanced chemicals, empowering scientists and researchers to drive progress in science and industry.

### Contact

Address: 3281 E Guasti Rd

Ontario, CA 91761, United States

Phone: (601) 213-4426

Email: [info@benchchem.com](mailto:info@benchchem.com)

Contact our Ph.D. Support Team for a compatibility check