

# Technical Guide: Biological Activity of Morpholine-Containing Sulfonamides

**Author:** BenchChem Technical Support Team. **Date:** May 2026

## Compound of Interest

Compound Name: *N-morpholin-4-yl-methanesulfonamide*

Cat. No.: B8475856

[Get Quote](#)

## Executive Summary

The Morpholine-Sulfonamide Conjugate represents a "privileged scaffold" in medicinal chemistry—a structural motif capable of binding to diverse biological targets with high affinity. This guide analyzes the synergistic integration of the sulfonamide moiety (a classic zinc-binding pharmacophore) with the morpholine ring (a pharmacokinetic modulator and hydrogen-bond acceptor).

This document serves as a technical blueprint for researchers, detailing the Structure-Activity Relationships (SAR), mechanistic pathways (Carbonic Anhydrase and Urease inhibition, Kinase targeting), and validated synthetic/experimental protocols required to develop these agents.

## Chemical Architecture & Rationale

The biological potency of this class stems from the complementary physicochemical properties of its two core components.

## The Pharmacophore Synergy

- The Sulfonamide (  $-SO_2NH_2$  ): Acts as a primary anchor, particularly in metalloenzymes. It functions as a Zinc-Binding Group (ZBG) in Carbonic Anhydrases (CAs) and coordinates with Nickel ions in Urease. The acidic proton (  $-SO_2NH-$  ) allows for specific electrostatic interactions.
- The Morpholine Ring: Unlike a simple aliphatic chain, the morpholine ring introduces a defined chair conformation. The ether oxygen serves as a weak hydrogen bond acceptor, while the ring enhances water solubility and metabolic stability compared to phenyl or piperidine analogs.

## SAR Logic Visualization

The following diagram illustrates the structural logic governing the design of these conjugates.

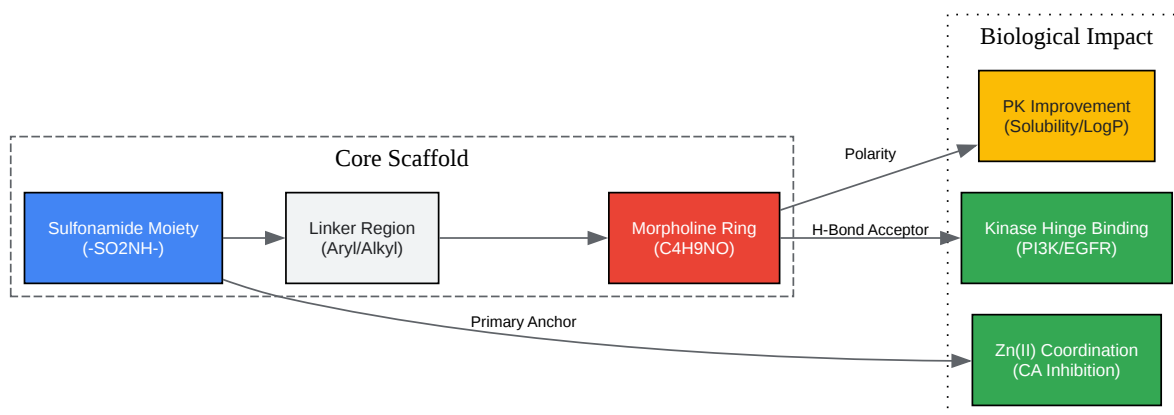

[Click to download full resolution via product page](#)

Figure 1: Structural dissection of morpholine-sulfonamide conjugates showing the functional role of each moiety in biological systems.

# Therapeutic Frontier: Carbonic Anhydrase Inhibition (CAI)

Morpholine-containing sulfonamides are potent inhibitors of human Carbonic Anhydrases (hCAs), specifically isoforms hCA II (glaucoma target) and hCA IX/XII (hypoxic tumor targets).

## Mechanism of Action

The sulfonamide anion (

) coordinates directly to the Zn(II) ion in the enzyme active site, displacing the catalytic water molecule/hydroxide ion. The morpholine tail extends into the enzyme's hydrophobic or hydrophilic pockets, determining isoform selectivity.

- hCA II (Cytosolic): Requires hydrophilic interactions. Morpholine tails often interact with residues near the active site entrance (e.g., Asn62, Gln92).
- hCA IX (Transmembrane/Tumor-associated): The morpholine ring can exploit the hydrophobic pocket specific to this isoform, improving selectivity over the ubiquitous hCA II.

## Quantitative Activity Profile

Representative data derived from structure-activity studies (e.g., Supuran et al., J. Med. Chem).<sup>[1][3][4][5][6][7][8][9][10][11][12]</sup>

| Compound Class                | Target Isoform | (nM)      | Selectivity (vs hCA I) | Therapeutic Relevance |
|-------------------------------|----------------|-----------|------------------------|-----------------------|
| Benzolamide-Morpholine        | hCA II         | 0.8 - 5.0 | >100-fold              | Glaucoma / Edema      |
| Ureido-Sulfonamide-Morpholine | hCA IX         | 12 - 45   | >50-fold               | Hypoxic Tumors        |
| SLC-0111 Analogues            | hCA XII        | 5 - 20    | >200-fold              | Metastatic Cancer     |

## Therapeutic Frontier: Urease Inhibition

Urease (nickel-dependent metalloenzyme) is a critical virulence factor for *Helicobacter pylori*. [13][14] Morpholine sulfonamides act as competitive inhibitors.

### Mechanistic Insight

Unlike the zinc-binding in CAs, in Urease, the sulfonamide group interacts with the Ni(II) binuclear center. The morpholine ring often engages in hydrogen bonding with distal residues (e.g., His593, Arg609), stabilizing the inhibitor-enzyme complex.

- Potency: Optimized morpholine derivatives often surpass standard inhibitors like acetohydroxamic acid (AHA) and thiourea.
- Key Interaction: The ether oxygen of morpholine acts as a crucial anchor point for water-bridged H-bonds within the active site flap.

## Therapeutic Frontier: Anticancer (Kinase Targeting)

Beyond CA inhibition, these scaffolds target specific kinases (PI3K, EGFR) involved in cell proliferation.

### PI3K/mTOR Pathway

The morpholine oxygen often mimics the ATP adenine N1 interaction at the kinase hinge region. When coupled with a sulfonamide (which often projects into the solvent-exposed region or interacts with the gatekeeper residue), these molecules induce apoptosis.

- Effect: Downregulation of p-Akt and induction of Bax/Bcl-2 mediated apoptosis.

## Chemical Synthesis Protocols

**Direct Sulfonylation Strategy** This is the most robust method for generating morpholine-sulfonamides.

## Synthesis Workflow Visualization

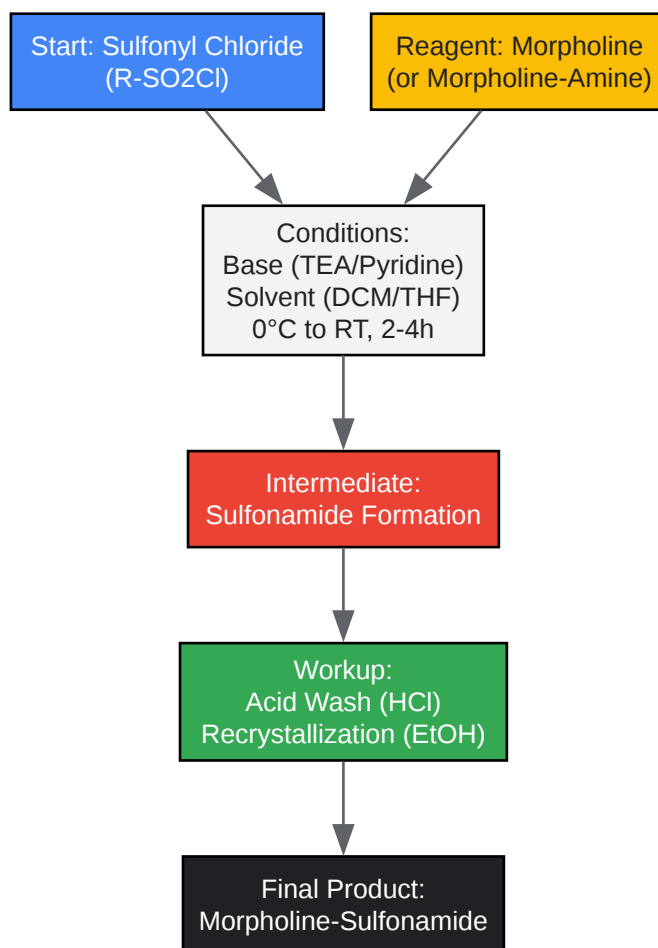

[Click to download full resolution via product page](#)

Figure 2: General synthetic pathway for the preparation of morpholine-sulfonamide derivatives.

## Detailed Synthetic Procedure

Objective: Synthesis of N-(4-morpholinophenyl)benzenesulfonamide.

- Reagents: 4-morpholinoaniline (1.0 eq), Benzenesulfonyl chloride (1.1 eq), Pyridine (solvent/base).
- Setup: Flame-dried round-bottom flask equipped with a magnetic stir bar and drying tube ( ).
- Execution:

- Dissolve 4-morpholinoaniline (e.g., 5 mmol) in dry pyridine (10 mL).
- Cool the solution to 0°C in an ice bath.
- Add Benzenesulfonyl chloride dropwise over 15 minutes to prevent exotherm.
- Allow the mixture to warm to Room Temperature (RT) and stir for 4–6 hours. Monitor via TLC (Mobile phase: Hexane/EtOAc 7:3).
- Workup:
  - Pour the reaction mixture into crushed ice-water (100 mL) containing concentrated HCl (5 mL) to neutralize pyridine.
  - A precipitate will form.<sup>[15]</sup> Filter the solid under vacuum.
  - Wash the cake with cold water ( mL).
- Purification: Recrystallize from Ethanol/Water (9:1) to yield the pure sulfonamide as white/off-white crystals.

## Experimental Validation Protocols

To ensure data integrity (E-E-A-T), use these standardized assays.

### Carbonic Anhydrase Inhibition Assay (Stopped-Flow)

Standard method to determine

against hCA isoforms.

- Principle: Measures the rate of the physiological reaction:  
.
- Indicator: Phenol red (changes color from red to yellow as pH drops).
- Protocol:

- Buffer: HEPES (20 mM, pH 7.5) with 20 mM  
.
- Enzyme: Recombinant hCA I, II, IX (concentration ~10 nM).
- Substrate:  
  
saturated water.
- Procedure: Incubate enzyme + inhibitor (varying concentrations  
  
to  
  
M) for 15 mins. Mix with substrate in a stopped-flow spectrophotometer.
- Measurement: Monitor absorbance decay at 557 nm. Calculate  
  
using the Cheng-Prusoff equation.

## Urease Inhibition Assay (Indophenol Method)

- Principle: Urease hydrolyzes urea to ammonia. Ammonia reacts with phenol/hypochlorite to form a blue indophenol complex.
- Protocol:
  - Mix: 25  
  
L Jack Bean Urease (or H. pylori urease) + 25  
  
L Test Compound. Incubate at 37°C for 15 min.
  - Substrate: Add 55  
  
L Urea (100 mM). Incubate 15 min at 37°C.
  - Development: Add 45  
  
L Phenol reagent + 70

L Alkali reagent. Incubate 50 min.

- Read: Absorbance at 630 nm.
- Control: Thiourea (Standard inhibitor).[14]

## Cell Viability Assay (MTT)

For Anticancer Screening (e.g., MCF-7, PC-3 lines).

- Seeding: Seed cells (cells/well) in 96-well plates. Incubate 24h.
- Treatment: Add morpholine-sulfonamide derivatives (serial dilutions). Incubate 48h.
- Assay: Add MTT reagent (5 mg/mL). Incubate 4h. Solubilize formazan crystals with DMSO.
- Read: Absorbance at 570 nm.

## References

- Supuran, C. T. (2008). Carbonic anhydrases: novel therapeutic applications for inhibitors and activators. *Nature Reviews Drug Discovery*. [Link](#)
- Nocentini, A., & Supuran, C. T. (2018). Carbonic anhydrase inhibitors as antitumor/antimetastatic agents: a patent review (2008-2018). *Expert Opinion on Therapeutic Patents*. [Link](#)
- Amtul, Z., et al. (2002). Chemistry and mechanism of urease inhibition. *Current Medicinal Chemistry*. [Link](#)
- Ghorab, M. M., et al. (2017). Novel sulfonamides bearing a morpholine moiety as anticancer agents: Design, synthesis, biological evaluation and molecular docking. *Journal of Enzyme Inhibition and Medicinal Chemistry*. [Link](#)
- Modi, P., et al. (2021). Morpholine: A privileged structure for the design of novel potent microbial inhibitors. *Future Medicinal Chemistry*. [Link](#)

### Need Custom Synthesis?

BenchChem offers custom synthesis for rare earth carbides and specific isotopic labeling.

Email: [info@benchchem.com](mailto:info@benchchem.com) or [Request Quote Online](#).

## Sources

- 1. [Frontiers | Exploration of morpholine-thiophene hybrid thiosemicarbazones for the treatment of ureolytic bacterial infections via targeting urease enzyme: Synthesis, biochemical screening and computational analysis \[frontiersin.org\]](#)
- 2. [mdpi.com \[mdpi.com\]](#)
- 3. [Morpholine synthesis \[organic-chemistry.org\]](#)
- 4. [researchgate.net \[researchgate.net\]](#)
- 5. [semanticscholar.org \[semanticscholar.org\]](#)
- 6. [researchgate.net \[researchgate.net\]](#)
- 7. [Decoding Urease Inhibition: A Comprehensive Review of Inhibitor Scaffolds - PMC \[pmc.ncbi.nlm.nih.gov\]](#)
- 8. [Revealing quinquennial anticancer journey of morpholine: A SAR based review - PubMed \[pubmed.ncbi.nlm.nih.gov\]](#)
- 9. [mathewsopenaccess.com \[mathewsopenaccess.com\]](#)
- 10. [ijpsonline.com \[ijpsonline.com\]](#)
- 11. [researchgate.net \[researchgate.net\]](#)
- 12. [mdpi.com \[mdpi.com\]](#)
- 13. [researchgate.net \[researchgate.net\]](#)
- 14. [Sulfonamide derivatives targeting urease: Structural diversity and therapeutic potential - Arabian Journal of Chemistry \[arabjchem.org\]](#)
- 15. [pdfs.semanticscholar.org \[pdfs.semanticscholar.org\]](#)
- To cite this document: BenchChem. [Technical Guide: Biological Activity of Morpholine-Containing Sulfonamides]. BenchChem, [2026]. [Online PDF]. Available at: [\[https://www.benchchem.com/product/b8475856/docs#technical-guide-biological-activity-of-morpholine-containing-sulfonamides\]](https://www.benchchem.com/product/b8475856/docs#technical-guide-biological-activity-of-morpholine-containing-sulfonamides)

**Disclaimer & Data Validity:**

The information provided in this document is for Research Use Only (RUO) and is strictly not intended for diagnostic or therapeutic procedures. While BenchChem strives to provide accurate protocols, we make no warranties, express or implied, regarding the fitness of this product for every specific experimental setup.

**Technical Support:** The protocols provided are for reference purposes. Unsure if this reagent suits your experiment?

**Need Industrial/Bulk Grade?** [Request Custom Synthesis Quote](#)

## BenchChem

Our mission is to be the trusted global source of essential and advanced chemicals, empowering scientists and researchers to drive progress in science and industry.

### Contact

Address: 3281 E Guasti Rd  
Ontario, CA 91761, United States  
Phone: (601) 213-4426  
Email: [info@benchchem.com](mailto:info@benchchem.com)

[Contact our Ph.D. Support Team for a compatibility check](#)