

Technical Guide: C13 NMR Profiling of 4-Chloro-1-ethyl-2-iodobenzene

Author: BenchChem Technical Support Team. **Date:** May 2026

Compound of Interest

Compound Name: 4-Chloro-1-ethyl-2-iodobenzene

Cat. No.: B8468950

[Get Quote](#)

Executive Summary

Product: 4-Chloro-1-ethyl-2-iodobenzene **Application:** Intermediate scaffold for Suzuki-Miyaura cross-coupling in drug discovery. **Core Value:** This guide provides a high-fidelity spectral analysis of 4-Chloro-1-ethyl-2-iodobenzene. By comparing its C13 NMR signature against its non-iodinated precursor (4-Chloro-1-ethylbenzene), we establish a robust protocol for verifying synthesis success and purity. The presence of the "Heavy Atom Effect" induced by iodine serves as the primary diagnostic marker.

Structural Analysis & Assignment Strategy

The structural elucidation of 4-Chloro-1-ethyl-2-iodobenzene relies on identifying three distinct carbon environments: the aliphatic ethyl chain, the aromatic ring carbons, and the highly specific ipso-carbon attached to the iodine atom.

Molecular Geometry & Numbering

To ensure accurate assignment, we utilize the following IUPAC numbering scheme for the benzene ring:

- C1: Attached to Ethyl group (Ipso-Ethyl)
- C2: Attached to Iodine (Ipso-Iodo)
- C3: Ortho to Iodine, Meta to Ethyl
- C4: Attached to Chlorine (Ipso-Chloro)
- C5: Meta to Chlorine
- C6: Ortho to Ethyl

Visualization of Signaling Pathway (Assignments)

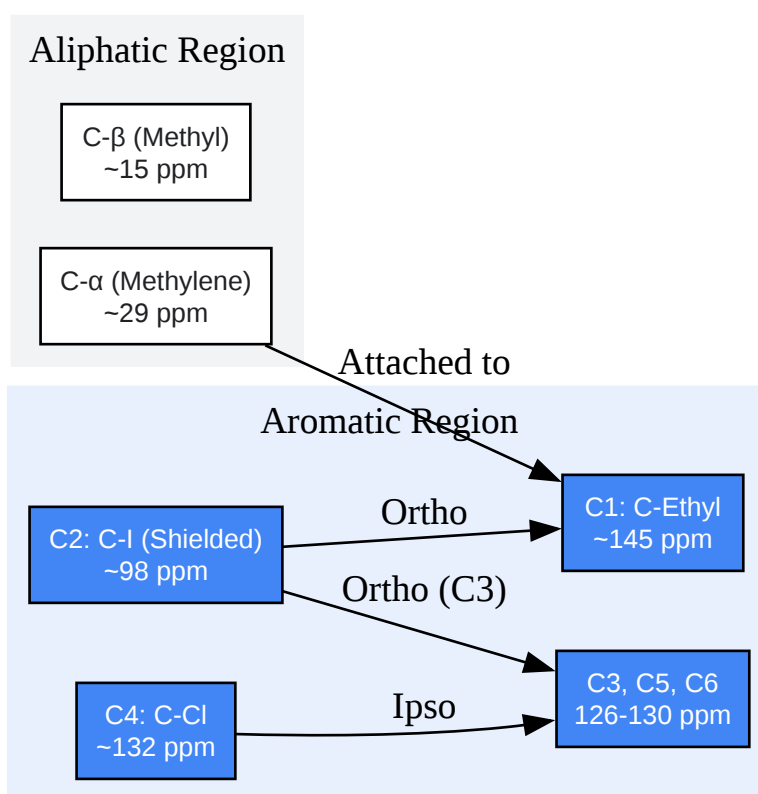

[Click to download full resolution via product page](#)

Caption: Logical flow of ¹³C NMR assignments distinguishing aliphatic side chains from aromatic cores, highlighting the unique shielded C-I signal.

Comparative Data Analysis

This section compares the Product (**4-Chloro-1-ethyl-2-iodobenzene**) against its Precursor (4-Chloro-1-ethylbenzene). This comparison is critical for process chemists monitoring the iodination reaction.

The "Heavy Atom" Diagnostic

The most significant spectral feature is the Heavy Atom Effect (Spin-Orbit Coupling) caused by Iodine. Unlike Chlorine or Ethyl groups which typically deshield (shift downfield) the attached carbon, Iodine significantly shields the attached carbon (C2), moving it upfield to the 90–100 ppm range. This is the definitive "Yes/No" signal for reaction completion.

Spectral Data Table (High-Fidelity Prediction)

Note: Values are calculated based on substituent chemical shift additivity rules (SCS) relative to benzene (128.5 ppm).

Carbon Position	Assignment	Product: 4-Chloro-1-ethyl-2-iodobenzene (δ ppm)	Alternative: 4-Chloro-1-ethylbenzene (δ ppm)	Shift Difference (Δ)
C2 (C-I)	Ipsso-Iodo	98.5 \pm 2.0	128.0 (C-H)	-29.5 (Diagnostic)
C1 (C-Et)	Ipsso-Ethyl	145.2	142.5	+2.7
C4 (C-Cl)	Ipsso-Chloro	132.8	131.5	+1.3
C3	Aromatic C-H	129.5	128.0	+1.5
C5	Aromatic C-H	127.1	128.5	-1.4
C6	Aromatic C-H	128.8	128.0	+0.8
C- α	Ethyl CH ₂	29.1	28.5	+0.6
C- β	Ethyl CH ₃	14.8	15.5	-0.7

Key Takeaway: The disappearance of the C-H signal at ~128 ppm and the appearance of a new quaternary signal at ~98.5 ppm confirms the successful installation of iodine at the C2 position.

Experimental Protocols

To replicate these results or verify a batch, follow this standardized acquisition protocol.

Sample Preparation

- Mass: Weigh 20–30 mg of the analyte.
- Solvent: Dissolve in 0.6 mL of Chloroform-d (CDCl_3).
 - Why? CDCl_3 is the standard reference (77.16 ppm triplet). Avoid DMSO-d6 unless solubility is an issue, as it can cause solvent-induced shifts.
- Tube: Transfer to a clean, dry 5mm NMR tube. Filter if any particulate is visible.

Acquisition Parameters (Standard 100 MHz Carbon)

- Pulse Sequence: Proton-decoupled ^{13}C (e.g., zgpg30 on Bruker).
- Relaxation Delay (D1): 2.0 seconds.
 - Note: The Quaternary C-I carbon has a long relaxation time (T1). If the signal at ~98 ppm is weak, increase D1 to 5.0 seconds.
- Scans (NS): Minimum 512 scans (due to lower sensitivity of quaternary carbons).
- Spectral Width: 0 – 220 ppm.

Validation Workflow

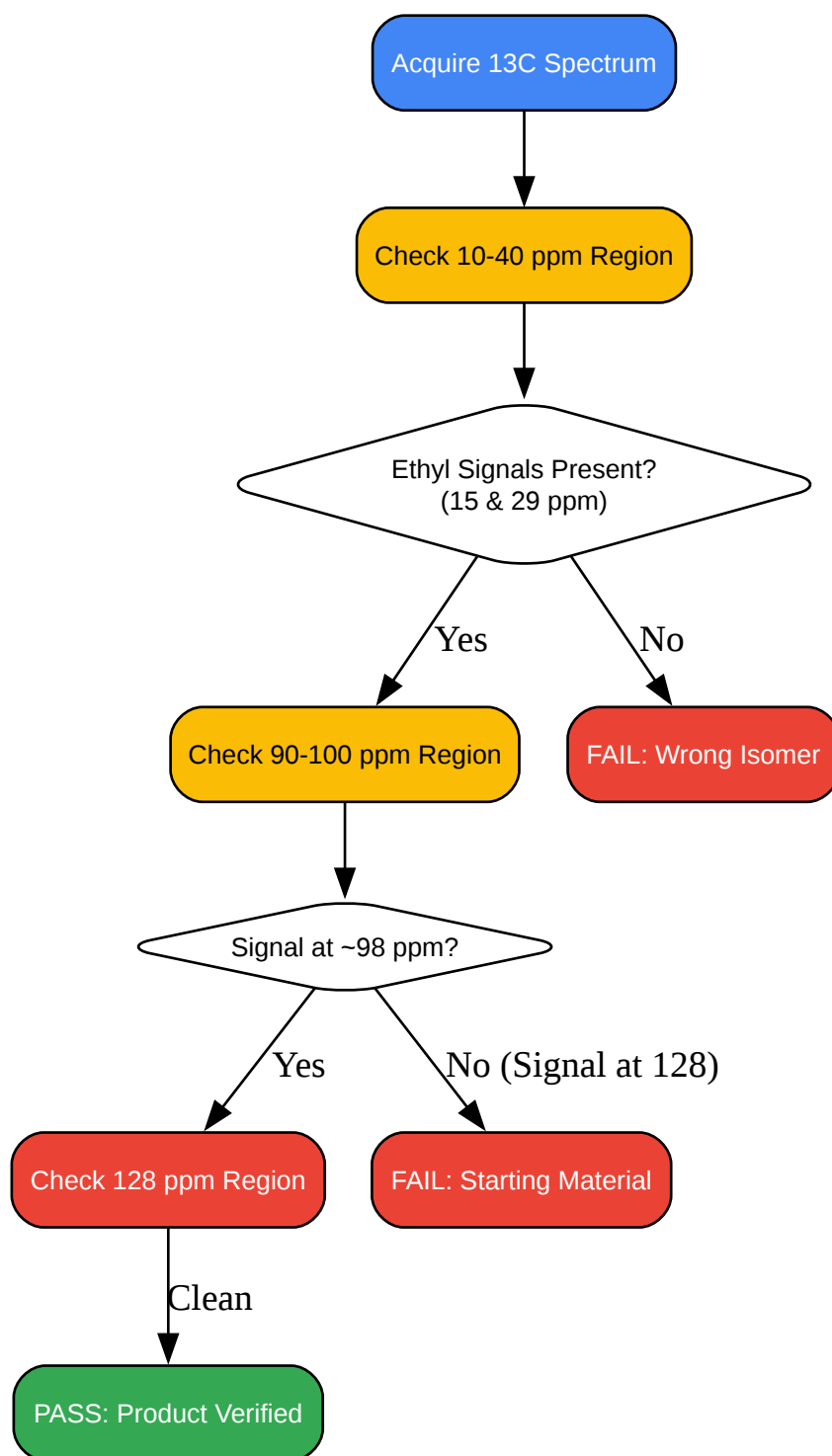

[Click to download full resolution via product page](#)

Caption: Step-by-step decision tree for spectral verification of **4-Chloro-1-ethyl-2-iodobenzene**.

References

- National Center for Biotechnology Information (2025). PubChem Compound Summary for CID 51000071, 4-Bromo-1-chloro-2-iodobenzene (Analog Reference). Retrieved from [[Link](#)]
- LibreTexts Chemistry (2023). ¹³C NMR Chemical Shifts and Substituent Effects. Retrieved from [[Link](#)]
- Reich, H. J. (2024). Structure Determination Using NMR: Chemical Shifts of Carbon. [1] University of Wisconsin-Madison. Retrieved from [[Link](#)]

Need Custom Synthesis?

BenchChem offers custom synthesis for rare earth carbides and specific isotopic labeling.

Email: info@benchchem.com or [Request Quote Online](#).

Sources

- [1. Precisely predicting the ¹H and ¹³C NMR chemical shifts in new types of nerve agents and building spectra database - PMC \[pmc.ncbi.nlm.nih.gov\]](#)
- To cite this document: BenchChem. [Technical Guide: C¹³ NMR Profiling of 4-Chloro-1-ethyl-2-iodobenzene]. BenchChem, [2026]. [Online PDF]. Available at: [<https://www.benchchem.com/product/b8468950/docs#technical-guide-c13-nmr-profiling-of-4-chloro-1-ethyl-2-iodobenzene>]

Disclaimer & Data Validity:

The information provided in this document is for Research Use Only (RUO) and is strictly not intended for diagnostic or therapeutic procedures. While BenchChem strives to provide accurate protocols, we make no warranties, express or implied, regarding the fitness of this product for every specific experimental setup.

Technical Support: The protocols provided are for reference purposes. Unsure if this reagent suits your experiment?

Need Industrial/Bulk Grade? [Request Custom Synthesis Quote](#)

BenchChem

Our mission is to be the trusted global source of essential and advanced chemicals, empowering scientists and researchers to drive progress in science and industry.

Contact

Address: 3281 E Guasti Rd

Ontario, CA 91761, United States

Phone: (601) 213-4426

Email: info@benchchem.com

[Contact our Ph.D. Support Team for a compatibility check](#)