

Technical Guide: Electrophilic Addition of Propyl Sulfenyl Chloride to Alkenes

Author: BenchChem Technical Support Team. **Date:** April 2026

Compound of Interest

Compound Name: *Propyl sulfenyl chloride*

Cat. No.: *B8456481*

[Get Quote](#)

Executive Summary

The electrophilic addition of **propyl sulfenyl chloride** (

) to alkenes represents a high-precision method for introducing sulfur-based functionalities into carbon scaffolds.^[1] Unlike the more common aryl sulfenyl chlorides, aliphatic analogs like

offer unique reactivity profiles and reduced steric bulk, making them valuable for constructing sterically congested motifs in drug candidates.^[1]

This guide details the mechanistic underpinnings, in situ generation protocols, and safety-critical handling requirements for this reaction. It specifically addresses the synthesis of

-chloro sulfides—versatile intermediates that serve as precursors for vinyl sulfides, episulfides, and complex heterocycles.^[1]

Critical Safety Advisory:

-Chloro sulfides are structurally related to sulfur mustards (vesicants).^[1] While propyl derivatives are generally less volatile/potent than ethyl analogs (Mustard Gas), they are potent alkylating agents.^[1] All procedures must be conducted in a functioning fume hood with appropriate PPE.

Mechanistic Framework

The reaction follows a classic electrophilic addition pathway, distinct from radical additions or concerted cycloadditions. Understanding this mechanism is prerequisite to controlling stereochemistry and regioselectivity.

The Episulfonium Intermediate

The reaction initiates with the attack of the alkene

-electrons on the electrophilic sulfur atom of

. This generates a bridged episulfonium (thiiranium) ion, not a discrete carbocation.[1]

- Stereochemical Control: The formation of the three-membered ring locks the stereochemistry. The subsequent nucleophilic attack by the chloride ion must occur from the backside (

 -like), resulting in exclusive anti-addition (trans-stereoselectivity).[1]
- Regiochemical Control: The chloride ion attacks the carbon atom of the episulfonium ring that can best support a partial positive charge.
 - Terminal Alkenes: Chloride attacks the more substituted carbon (Markovnikov orientation regarding the electrophile).
 - Result: The propylthio group (

) attaches to the less substituted carbon, and the chlorine atom attaches to the more substituted carbon.

Visualization of the Pathway[2]

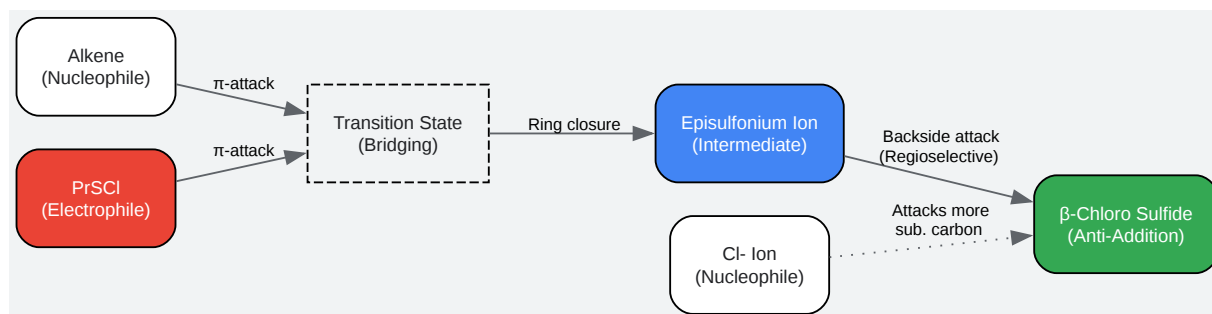

[Click to download full resolution via product page](#)

Figure 1: Mechanistic pathway showing the formation of the bridged episulfonium ion and subsequent anti-addition.

Reagent Preparation: In Situ Generation

Aliphatic sulfenyl chlorides are thermally unstable and hygroscopic. They cannot be stored and must be generated immediately prior to use.

The Disulfide-Sulfuryl Chloride Method

The most reliable method for generating high-purity

involves the chlorinolysis of dipropyl disulfide using sulfuryl chloride (

). This method avoids the handling of gaseous chlorine (

) and allows for precise stoichiometry.

Reaction:

Preparation Workflow

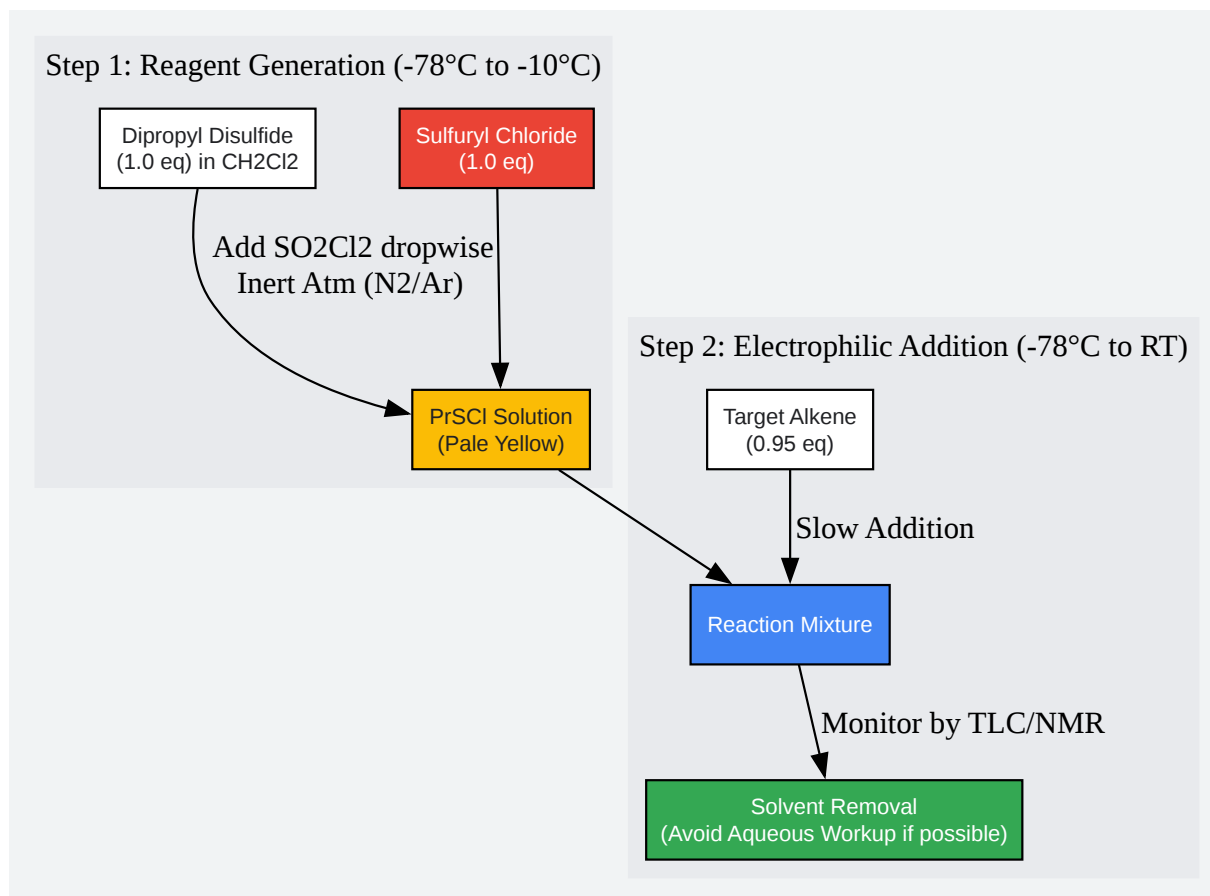

[Click to download full resolution via product page](#)

Figure 2: Workflow for the in situ generation of **propyl sulfenyl chloride** and subsequent addition.

Experimental Protocol (SOP)

Objective: Synthesis of 2-chloro-1-(propylthio)cyclohexane from cyclohexene.

Materials & Equipment

- Reagents: Dipropyl disulfide (>98%), Sulfuryl chloride (, distilled), Cyclohexene, Dichloromethane (anhydrous).[1]

- Equipment: 3-neck round bottom flask, addition funnel, nitrogen line, cooling bath (or Acetone/dry ice).

Step-by-Step Methodology

- System Preparation: Flame-dry a 250 mL 3-neck flask under a stream of dry nitrogen.
- Reagent Formation:
 - Charge the flask with Dipropyl disulfide (10.0 mmol) and anhydrous (50 mL).
 - Cool the solution to (ice/salt bath) or if high selectivity is required.
 - Add Sulfuryl chloride (10.0 mmol) dropwise over 10 minutes.
 - Observation: The solution should turn a pale yellow/orange color. Gas evolution () will occur; ensure proper venting.
 - Stir for 15 minutes to ensure complete conversion to .
- Alkene Addition:
 - Cool the mixture to (Dry ice/Acetone).
 - Dissolve Cyclohexene (19.0 mmol, 0.95 eq relative to generated PrSCI) in (10 mL).

- Add the alkene solution dropwise over 20 minutes. Note: Slight excess of PrSCI ensures complete consumption of the alkene.
- Reaction & Warm-up:
 - Allow the reaction to warm slowly to room temperature over 2 hours.
 - Monitor conversion via TLC (Note:
 - chloro sulfides can be unstable on silica; use neutral alumina or run quickly).[1]
- Workup:
 - Concentrate the mixture under reduced pressure (rotary evaporator) at low temperature (<).
 - Purification: If necessary, rapid filtration through a neutral alumina plug using Hexanes/EtOAc.[1] Avoid aqueous washes if the product is prone to hydrolysis.

Scope and Regioselectivity Data

The regioselectivity is dictated by the electronic nature of the alkene. The following table summarizes expected outcomes based on standard alkyl sulfenyl chloride reactivity.

Alkene Type	Structure	Major Product Structure	Regioselectivity	Yield (Typical)
Terminal			Markovnikov*	85-95%
Symmetrical Internal			N/A (Anti-addition)	90-98%
Styrenyl			Markovnikov	>95%
Conjugated Diene		1,2-addition dominant	Mixed	60-75%

*Note: "Markovnikov" here refers to the electrophile (

) adding to the less substituted carbon, placing the Cl on the more substituted carbon.

Applications in Drug Development[3][4]

Functionalization Handles

The

-chloro sulfide motif is rarely the final endpoint in drug design due to its reactivity. Instead, it serves as a "loaded spring" for further elaboration:

- Vinyl Sulfides: Elimination of (using bases like DBU) yields vinyl sulfides, which are valuable Michael acceptors.[1]
- Episulfides: Treatment with mild nucleophiles can reform the thiirane ring, a bioisostere of epoxides.
- Heterocycle Synthesis: Reaction with internal nucleophiles (e.g., pendant amines or alcohols) facilitates the rapid construction of sulfur-containing heterocycles like dihydrothiazoles.[1]

Bioisosterism

The propylthio group (

) is a lipophilic side chain. In medicinal chemistry, modifying the alkyl chain length (Methyl vs. Propyl) allows for fine-tuning of:

- LogP (Lipophilicity): Propyl increases lipophilicity significantly compared to methyl.[1]
- Metabolic Stability: The sulfur atom is a site for oxidation (to sulfoxide/sulfone), altering the pharmacokinetic profile.

References

- Mellor, J. M. (2021).[1] Electrophilic Addition to Alkenes. In Organic Reaction Mechanisms. Wiley. [Link](#)

- Bahrami, K., Khodaei, M. M., & Soheilzad, M. (2009).[1][2] A Novel, Practical Synthesis of Sulfonyl Chlorides from Thiol and Disulfide Derivatives. *Synlett*, 2009(17), 2773-2776. [Link\[1\]](#)
- Schmid, G. H., & Tidwell, T. T. (1978).[1][3] Reactivity of cyclopropylalkenes with p-chlorobenzenesulfonyl chloride. *Canadian Journal of Chemistry*, 56(2), 205-210. [Link](#)
- Drabowicz, J., & Kielbasinski, P. (2008).[1] Alkanesulfonyl Halides. In *Science of Synthesis: Houben-Weyl Methods of Molecular Transformations (Vol. 39)*. Thieme. [Link](#)
- Master Organic Chemistry. (2013). Alkene Addition Reactions: Regioselectivity and Stereoselectivity. [Link](#)

Need Custom Synthesis?

BenchChem offers custom synthesis for rare earth carbides and specific isotopic labeling.

Email: info@benchchem.com or [Request Quote Online](#).

Sources

- 1. [mdpi.com](https://www.mdpi.com) [[mdpi.com](https://www.mdpi.com)]
- 2. A Novel, Practical Synthesis of Sulfonyl Chlorides from Thiol and Disulfide Derivatives [[organic-chemistry.org](https://www.organic-chemistry.org)]
- 3. [cdnsiencepub.com](https://www.cdnsiencepub.com) [[cdnsiencepub.com](https://www.cdnsiencepub.com)]
- To cite this document: BenchChem. [Technical Guide: Electrophilic Addition of Propyl Sulfonyl Chloride to Alkenes]. BenchChem, [2026]. [Online PDF]. Available at: [<https://www.benchchem.com/product/b8456481/docs#technical-guide-electrophilic-addition-of-propyl-sulfonyl-chloride-to-alkenes>]

Disclaimer & Data Validity:

The information provided in this document is for Research Use Only (RUO) and is strictly not intended for diagnostic or therapeutic procedures. While BenchChem strives to provide accurate protocols, we make no warranties, express or implied, regarding the fitness of this product for every specific experimental setup.

Technical Support: The protocols provided are for reference purposes. Unsure if this reagent suits your experiment?

Need Industrial/Bulk Grade? [Request Custom Synthesis Quote](#)

BenchChem

Our mission is to be the trusted global source of essential and advanced chemicals, empowering scientists and researchers to drive progress in science and industry.

Contact

Address: 3281 E Guasti Rd
Ontario, CA 91761, United States
Phone: (601) 213-4426
Email: info@benchchem.com

[Contact our Ph.D. Support Team for a compatibility check](#)