

# Comparative Mass Spectrometry Guide: Fragmentation Dynamics of Diiodinated Phenols

**Author:** BenchChem Technical Support Team. **Date:** April 2026

## Compound of Interest

Compound Name: 2-Fluoro-4,6-diiodophenol

Cat. No.: B8452982

[Get Quote](#)

## Executive Summary & Scientific Context

Diiodinated phenols (DIPs), specifically isomers like 2,4-diiodophenol and 2,6-diiodophenol, are critical analytes in two distinct fields: environmental toxicology (as unregulated disinfection byproducts in iodinated water) and pharmaceutical synthesis (as thyromimetic precursors).

Their analysis presents a unique challenge: the carbon-iodine (C-I) bond is the weakest among common organic halogens (~213 kJ/mol), leading to rapid fragmentation that can obscure the molecular ion if ionization energy is not carefully controlled. This guide compares the fragmentation behaviors of DIPs against their chlorinated/brominated analogs and differentiates between ionization modalities (EI vs. ESI).

## The Comparative Landscape: EI vs. ESI

The choice between Electron Ionization (GC-MS) and Electrospray Ionization (LC-MS) dictates the fragmentation topology.

## Table 1: Ionization Modality Comparison for Diiodophenols

Feature	Electron Ionization (EI, 70 eV)	Electrospray Ionization (ESI, Negative Mode)
Primary Ion	Radical Cation (m/z ~346)	Deprotonated Pseudomolecular Ion (m/z ~345)
Dominant Mechanism	Homolytic Cleavage (Radical site initiation)	Heterolytic Cleavage / Collision Induced Dissociation (CID)
Key Fragment Ions	m/z 219 , m/z 218	m/z 127 , m/z 217
Structural Insight	High (Fingerprint fragmentation)	Moderate (Requires MS/MS for structural data)
Sensitivity	Moderate (Derivatization often required)	High (Excellent for acidic phenols)
Suitability	Structural elucidation of unknowns	Quantification in complex matrices (biological/water)

## Mechanistic Deep Dive: Fragmentation Pathways

### The "Weak Link" Hypothesis

Unlike chlorophenols, where the C-Cl bond (~327 kJ/mol) is robust enough to allow ring cleavage (loss of CO) to compete with halogen loss, diiodophenols are dominated by the lability of the C-I bond.

- Chlorinated Phenols: Often show

or

.

- Iodinated Phenols: Almost exclusively initiate via C-I cleavage.

### The Ortho-Effect (Isomer Differentiation)

The proximity of the iodine atom to the phenolic hydroxyl group is the diagnostic key.

- 2,4-Diiodophenol: Contains one ortho-iodine.
- 2,6-Diiodophenol: Contains two ortho-iodines.

Mechanism: The "Ortho Effect" facilitates the elimination of hydrogen iodide (HI, 128 Da) rather than just the iodine radical (I, 127 Da). A 1,4-hydrogen shift from the hydroxyl group to the iodine allows for the neutral loss of HI, generating a stable keto-carbene or quinoid-type ion.

“

*Diagnostic Rule: A higher ratio of*

(m/z 218) to

(m/z 219) is often indicative of 2,6-substitution due to the statistical probability (two ortho iodines) and steric facilitation.

## Visualizing the Fragmentation Pathway

The following diagram illustrates the primary decay channels for 2,4-diiodophenol under Electron Ionization.

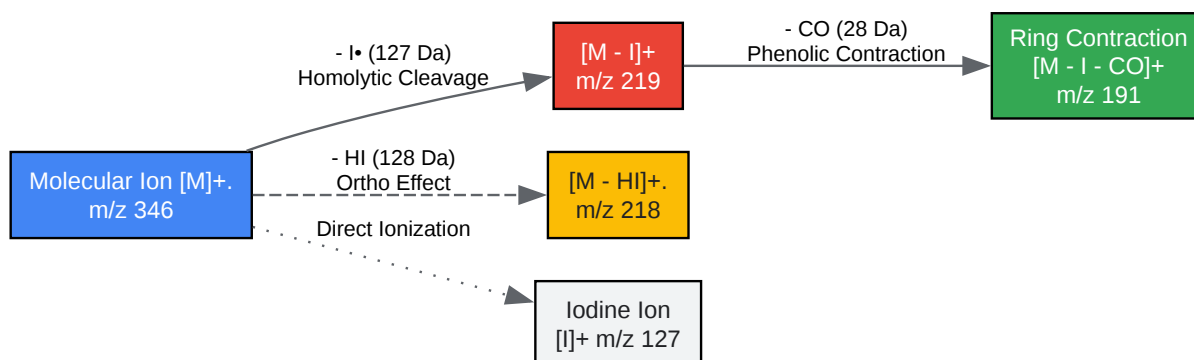

[Click to download full resolution via product page](#)

Figure 1: EI Fragmentation pathway of 2,4-Diiodophenol showing competitive loss of Iodine radical vs. HI neutral loss.

## Experimental Protocol: LC-MS/MS Quantification

While EI provides structural data, modern drug development and environmental analysis rely on LC-MS/MS (ESI-) for sensitivity. This protocol is self-validating through the use of internal standards.

### Reagents & Standards

- Analyte: 2,4-Diiodophenol & 2,6-Diiodophenol standards (>98% purity).
- Internal Standard (IS): 2,4,6-Tribromophenol or  
-2,4-Dichlorophenol (distinct mass defect and retention time).
- Solvents: LC-MS grade Methanol and Water (buffered with 0.1% Formic Acid or Ammonium Acetate to stabilize pH).

### Workflow Diagram

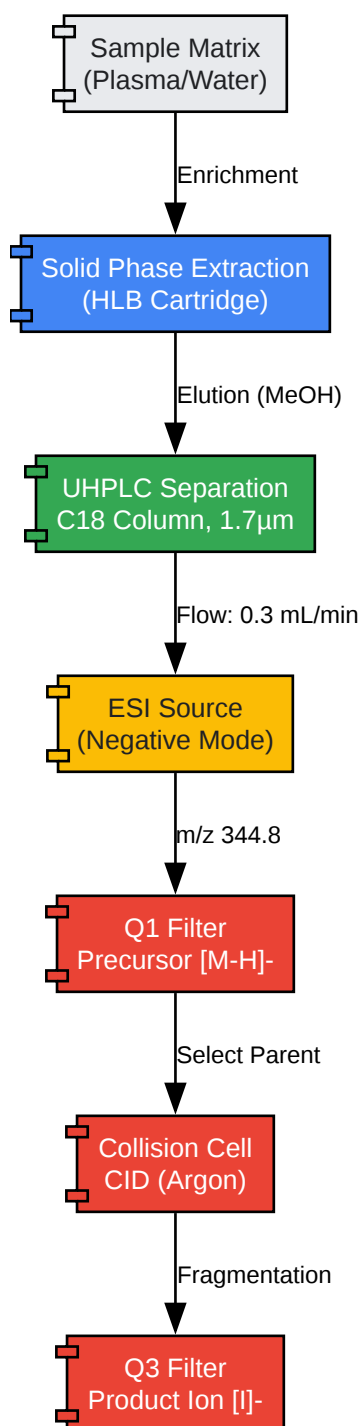

[Click to download full resolution via product page](#)

Figure 2: MRM Workflow for sensitive detection of diiodophenols using Negative ESI.

## Step-by-Step Methodology

- Sample Preparation: Acidify sample to pH < 2 to protonate phenols, enhancing retention on SPE cartridges.
- LC Separation: Use a C18 reverse-phase column.
  - Gradient: 5% MeOH to 95% MeOH over 8 minutes.
  - Rationale: Diiodophenols are hydrophobic (logP ~3.0); high organic content is needed for elution.
- MS/MS Transitions (MRM):
  - Precursor: m/z 344.8
  - Quantifier Product: m/z 126.9  
(Most intense, but non-specific).
  - Qualifier Product: m/z 216.9  
(Structural confirmation).
  - Note: The transition to m/z 127 is ubiquitous for iodinated compounds. You must rely on chromatographic resolution to distinguish isomers.

## Comparison with Alternatives

### Table 2: Halogenated Phenol Fragmentation Metrics

Analyte	Bond Energy (C-X)	Primary Neutral Loss (EI)	Base Peak (EI)	Diagnostic Feature
Diiodophenol	~213 kJ/mol	Iodine radical ( )	or	Massive mass defect; rapid I loss.
Dibromophenol	~285 kJ/mol	Bromine radical ( )		Isotope pattern (1:2:1) for .
Dichlorophenol	~327 kJ/mol	CO (28 Da) or HCl		Isotope pattern (9:6:1) for .

Key Insight: While chlorinated phenols retain the halogen longer, allowing for ring-specific fragmentation, diiodophenols lose iodine so readily that the spectrum is often dominated by the de-iodinated phenolic core. This makes soft ionization (like Cold EI or ESI) crucial if molecular weight confirmation is required.

## References

- NIST Chemistry WebBook. Mass Spectrum of 2,4-Diiodophenol. National Institute of Standards and Technology. [\[Link\]](#)
- Lebedev, A. T. (2013). Mass Spectrometry of Environmental Organic Pollutants. Comprehensive guide on halogenated phenol fragmentation. [\[Link\]](#)
- EPA Method 528. Determination of Phenols in Drinking Water by GC-MS. U.S. Environmental Protection Agency. [\[Link\]](#)
- Doc Brown's Chemistry. Fragmentation Patterns of Phenols in Mass Spectrometry. [\[Link\]](#)
- Save My Exams. Mass Spectrometry Fragmentation Patterns (HL). [\[Link\]](#)

- To cite this document: BenchChem. [Comparative Mass Spectrometry Guide: Fragmentation Dynamics of Diiodinated Phenols]. BenchChem, [2026]. [Online PDF]. Available at: [<https://www.benchchem.com/product/b8452982/docs#comparative-mass-spectrometry-guide-fragmentation-dynamics-of-diiodinated-phenols>]

---

### Disclaimer & Data Validity:

The information provided in this document is for Research Use Only (RUO) and is strictly not intended for diagnostic or therapeutic procedures. While BenchChem strives to provide accurate protocols, we make no warranties, express or implied, regarding the fitness of this product for every specific experimental setup.

**Technical Support:** The protocols provided are for reference purposes. Unsure if this reagent suits your experiment?

**Need Industrial/Bulk Grade?** [Request Custom Synthesis Quote](#)

## BenchChem

Our mission is to be the trusted global source of essential and advanced chemicals, empowering scientists and researchers to drive progress in science and industry.

### Contact

Address: 3281 E Guasti Rd  
Ontario, CA 91761, United States  
Phone: (601) 213-4426  
Email: [info@benchchem.com](mailto:info@benchchem.com)

[Contact our Ph.D. Support Team for a compatibility check](#)