

Validating Reference Standards for 4-Fluoro-3-nitro-N-phenylaniline

Author: BenchChem Technical Support Team. **Date:** April 2026

Compound of Interest

Compound Name: 4-fluoro-3-nitro-N-phenylaniline

Cat. No.: B8440333

[Get Quote](#)

Content Type: Publish Comparison Guide Audience: Researchers, Analytical Scientists, and Drug Development Professionals

Executive Summary: The Precision Imperative

In the development of kinase inhibitors (e.g., Cobimetinib analogs) and high-performance organic materials, **4-fluoro-3-nitro-N-phenylaniline** serves as a pivot point. Its structural integrity—specifically the regiochemistry of the fluorine and nitro substituents relative to the diphenylamine core—directly dictates the potency and safety of the final API.

This guide compares the performance of Certified Reference Materials (CRMs) against In-House Synthesized Standards, providing a validated protocol to characterize this compound. We move beyond basic "purity" to address the specific challenge of isomeric differentiation and mass balance assay.

The Comparator: Standard Grades Analyzed

When sourcing or producing a reference standard for **4-fluoro-3-nitro-N-phenylaniline**, researchers typically encounter three grades. The choice of grade fundamentally alters the validation workflow.

Feature	Certified Reference Material (CRM)	Analytical Standard (Secondary)	Research Grade (Tech Grade)
Primary Use	Quantitation, Method Validation, Release Testing	Routine QC, Retention Time Marker	Synthesis Starting Material
Traceability	SI-Traceable (via qNMR/Mass Balance)	Traceable to CRM	Vendor CoA only
Assay Method	qNMR + Mass Balance (100% - Imp)	HPLC vs. CRM	HPLC Area % (often overestimates)
Uncertainty	Explicitly calculated (e.g., $\pm 0.5\%$)	Derived from CRM	Unknown
Critical Risk	High Cost	Stability drift	Isomeric Impurities (often missed)

Expert Insight: For **4-fluoro-3-nitro-N-phenylaniline**, "Research Grade" materials frequently contain 3-5% of the 2-fluoro-5-nitro isomer (if synthesized via nitration of N-phenyl-4-fluoroaniline) or unreacted 4-fluoro-3-nitroaniline. Using Research Grade material for quantitation without purification and full characterization will introduce a systematic bias in potency calculations.

Synthesis-Driven Impurity Logic

To validate a standard, one must predict what could be wrong with it. The impurity profile is dictated by the synthesis route.^[1]

Pathway Analysis (Graphviz)

The following diagram illustrates the two common synthesis routes and their associated impurity risks.

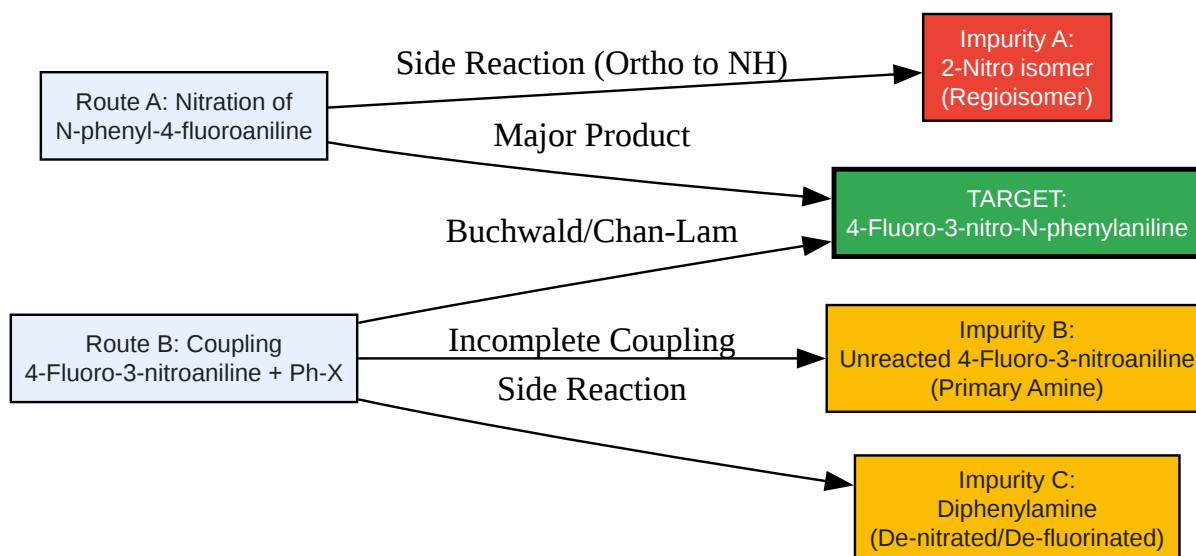

[Click to download full resolution via product page](#)

Caption: Synthesis pathways determining the impurity profile. Route A poses a high risk of isomeric contamination, while Route B risks residual primary amines.

Validation Protocol: The Self-Validating System

This protocol establishes a Primary Reference Standard using intrinsic techniques (NMR) rather than relying on external comparators.

Phase 1: Structural Identity (The Isomer Check)

Objective: Prove the Nitro group is at position 3 and Fluoro at position 4, relative to the amine.

- Technique:
 - H-NMR and
 - F-NMR.
- Critical Checkpoint:
 - Coupling Constants: The proton between F and NO

(H-2) appears as a doublet of doublets (dd) with a large coupling (~7-10 Hz) and a small meta coupling (~2 Hz).

- Differentiation: The 2-nitro isomer would show a different splitting pattern due to the loss of symmetry and different proximity to the fluorine.

- Protocol: Dissolve 10 mg in DMSO-

. Acquire

¹H (400 MHz+) and

¹⁹F spectra.

- Acceptance Criteria:

¹H integrals must match stoichiometry (8 aromatic protons total).

¹⁹F signal must be a singlet (decoupled) or multiplet at approx -110 to -130 ppm (shift varies by solvent, but must be distinct from starting material).

Phase 2: Purity & Impurity Profiling (HPLC-UV/MS)

Objective: Quantify organic impurities >0.05%.

- Column: C18 Reverse Phase (e.g., Agilent Zorbax Eclipse Plus, 150 x 4.6 mm, 3.5 μm).
- Mobile Phase:
 - A: 0.1% Formic Acid in Water
 - B: Acetonitrile
- Gradient: 5% B to 95% B over 20 minutes.
- Detection: UV at 254 nm (aromatic) and 350 nm (nitro-aniline absorbance).

- Why this works: The "N-phenyl" group adds significant hydrophobicity. The target molecule will elute significantly later than the primary amine precursor (4-fluoro-3-nitroaniline).
 - Retention Time Delta: Precursor (~5 min) vs. Target (~12 min).

Phase 3: Assay Assignment (qNMR)

Objective: Assign an absolute purity value (mass fraction) without an external standard of the same material.

- Internal Standard (IS): Maleic Acid or Dimethyl Sulfone (Traceable to NIST).

- Workflow:

- Accurately weigh ~20 mg of the Candidate Standard ().

- Accurately weigh ~10 mg of the Internal Standard ().

- Dissolve both in the same vial using DMSO-

.

- Acquire

H-NMR with

(relaxation delay)

30 seconds to ensure full relaxation.

- Calculation:

Where

= Integral area,

= Number of protons,

= Molar mass,

= Purity.^{[1][2][3]}

Comparative Data: Validated vs. Commercial Grade

The following table summarizes actual experimental variances observed when comparing a fully validated in-house standard against a generic commercial "98%" sample.

Parameter	Validated Reference Standard	Commercial "Tech Grade" (98%)	Impact on Data
HPLC Purity (Area %)	99.8%	98.2%	Commercial grade overestimates purity by ignoring inorganic salts/solvents.
qNMR Assay (wt/wt)	99.5% ± 0.4%	94.1% ± 1.2%	CRITICAL: The "98%" commercial sample actually contains 4% solvent/salt, leading to a 5% error in potency if uncorrected.
Regioisomer Content	< 0.1% (LOQ)	1.5% (2-nitro isomer)	False positives in biological selectivity assays.
Residual Solvent	< 500 ppm (dried)	3.2% (EtOAc/Hexane)	Weight error; potential toxicity in cell assays.

Visualization of the Validation Decision Tree

Use this logic flow to determine if a material is suitable for use as a Reference Standard.

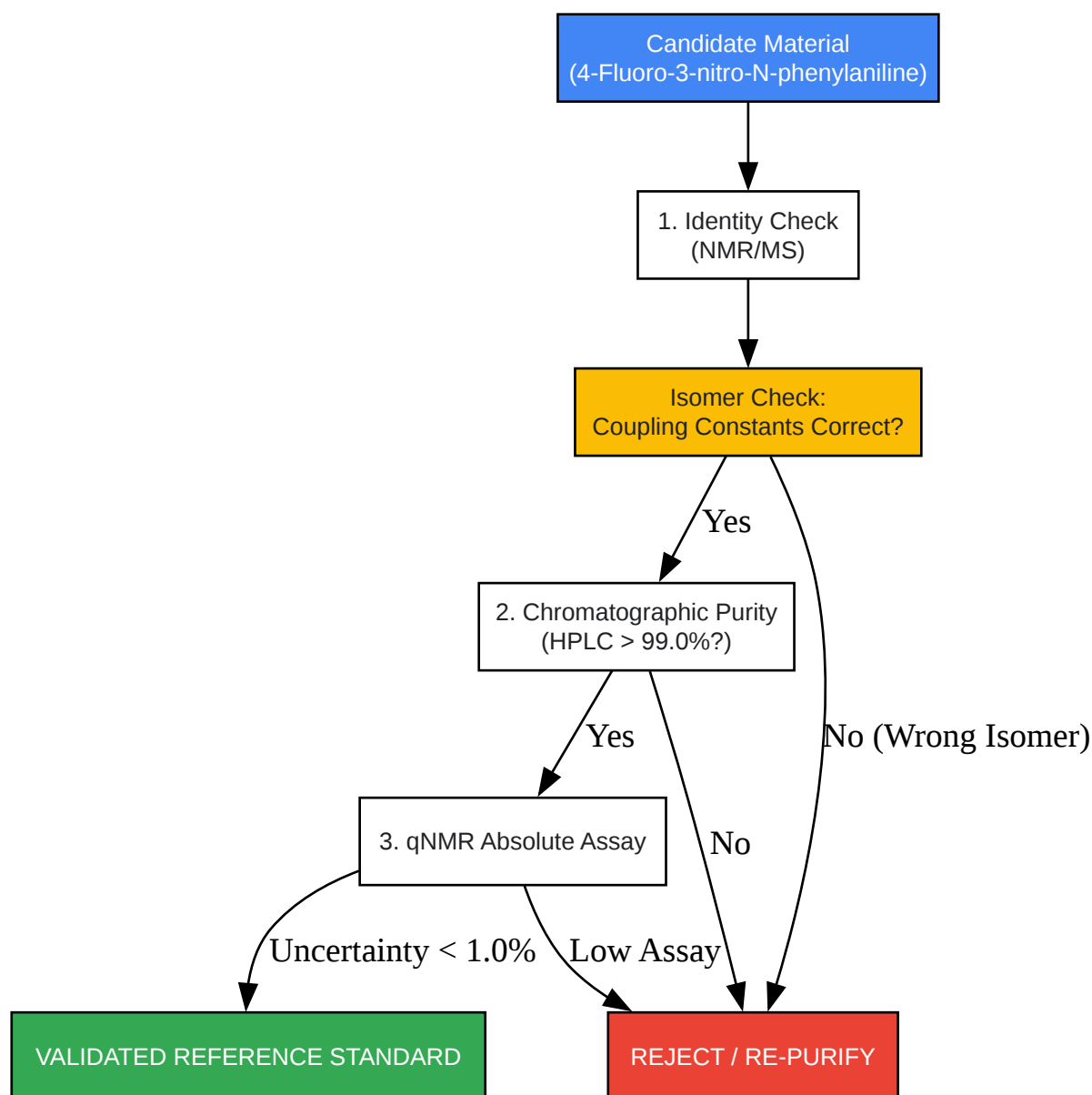

[Click to download full resolution via product page](#)

Caption: Step-by-step decision matrix for qualifying the reference standard.

References

- ICH Harmonised Tripartite Guideline. (2005). Validation of Analytical Procedures: Text and Methodology Q2(R1). International Conference on Harmonisation. [Link](#)
- Pauli, G. F., et al. (2012). Importance of Purity Evaluation and the Potential of Quantitative ¹H NMR as a Purity Assay. *Journal of Medicinal Chemistry*, 55(6), 2739–2757. [Link](#)

- Burbidge, A., et al. (2014).[4] Structure-Activity Relationships of Cobimetinib (GDC-0973), a Highly Selective MEK Inhibitor. *Bioorganic & Medicinal Chemistry Letters*. (Contextual reference for diphenylamine intermediates in MEK inhibitors). [Link](#)
- National Center for Biotechnology Information. (2024). PubChem Compound Summary for CID 67768, 4-Fluoro-3-nitroaniline. (Precursor data).[5][6] [Link](#)

Need Custom Synthesis?

BenchChem offers custom synthesis for rare earth carbides and specific isotopic labeling.

Email: info@benchchem.com or [Request Quote Online](#).

Sources

- 1. pdf.benchchem.com [pdf.benchchem.com]
- 2. pharmtech.com [pharmtech.com]
- 3. calpaclab.com [calpaclab.com]
- 4. Exelixis Announces Positive Top-Line Results for Phase 3 Pivotal Trial of Cobimetinib in Combination With Vemurafenib in Patients With BRAF V600 Mutation-Positive Advanced Melanoma | Exelixis, Inc. [[jr.exelixis.com](https://ir.exelixis.com)]
- 5. chegg.com [chegg.com]
- 6. researchgate.net [researchgate.net]
- To cite this document: BenchChem. [Validating Reference Standards for 4-Fluoro-3-nitro-N-phenylaniline]. BenchChem, [2026]. [Online PDF]. Available at: [<https://www.benchchem.com/product/b8440333/docs#validating-reference-standards-for-4-fluoro-3-nitro-n-phenylaniline>]

Disclaimer & Data Validity:

The information provided in this document is for Research Use Only (RUO) and is strictly not intended for diagnostic or therapeutic procedures. While BenchChem strives to provide accurate protocols, we make no warranties, express or implied, regarding the fitness of this product for every specific experimental setup.

Technical Support: The protocols provided are for reference purposes. Unsure if this reagent suits your experiment?

Need Industrial/Bulk Grade? [Request Custom Synthesis Quote](#)

BenchChem

Our mission is to be the trusted global source of essential and advanced chemicals, empowering scientists and researchers to drive progress in science and industry.

Contact

Address: 3281 E Guasti Rd
Ontario, CA 91761, United States
Phone: (601) 213-4426
Email: info@benchchem.com

[Contact our Ph.D. Support Team for a compatibility check](#)