

# Introduction: The Strategic Importance of the 2-Nitrobiphenyl Scaffold

**Author:** BenchChem Technical Support Team. **Date:** April 2026

## Compound of Interest

**Compound Name:** 4-Aminomethyl-2'-nitro-1,1'-biphenyl

**Cat. No.:** B8436583

[Get Quote](#)

The 2-nitro-1,1'-biphenyl framework is a cornerstone in modern organic chemistry, serving as a pivotal structural motif in pharmaceuticals, agrochemicals, and advanced materials.[1] Biphenyl derivatives, in general, are prevalent in numerous biologically active compounds and functional materials like liquid crystals and organic light-emitting diodes (OLEDs).[1] The strategic placement of a nitro group at the 2-position introduces a unique combination of steric and electronic properties. This functional group not only influences the molecule's conformation, often leading to the fascinating phenomenon of atropisomerism, but also serves as a versatile synthetic handle for a multitude of chemical transformations.[2][3]

This guide offers a comprehensive exploration of 2-nitro-1,1'-biphenyl derivatives, intended for researchers, scientists, and professionals in drug development. We will delve into the principal synthetic methodologies, elucidate the key physicochemical properties, and showcase their critical applications, particularly as precursors to carbazole alkaloids and other valuable N-heterocycles.

## Part 1: Core Synthetic Methodologies

The construction of the C(sp<sup>2</sup>)-C(sp<sup>2</sup>) bond linking the two phenyl rings is the central challenge in synthesizing 2-nitrobiphenyls. Over the years, several powerful methods have emerged, with transition-metal-catalyzed cross-coupling reactions being the most prominent.

## Suzuki-Miyaura Cross-Coupling: A Versatile and High-Yielding Approach

The palladium-catalyzed Suzuki-Miyaura cross-coupling reaction is arguably the most efficient and widely used method for preparing 2-nitrobiphenyls.<sup>[4][5]</sup> The reaction typically involves the coupling of a 2-nitroaryl halide with a phenylboronic acid in the presence of a palladium catalyst and a base.<sup>[6][7]</sup>

**Mechanism and Causality:** The catalytic cycle begins with the oxidative addition of the aryl halide to a Pd(0) complex. This is followed by transmetalation with the boronic acid (activated by the base to form a boronate species) and concludes with reductive elimination, which yields the biphenyl product and regenerates the Pd(0) catalyst.<sup>[5]</sup> The choice of catalyst, ligand, base, and solvent system is critical for achieving high yields and can be tailored to the specific substrates. For instance, the use of highly active catalysts like Pd(PPh<sub>3</sub>)<sub>4</sub> allows for the coupling of even less reactive 1-chloro-2-nitrobenzenes. Microwave heating has been shown to accelerate the reaction rate significantly.<sup>[7][8]</sup>

Suzuki-Miyaura Cross-Coupling for 2-Nitrobiphenyl Synthesis.

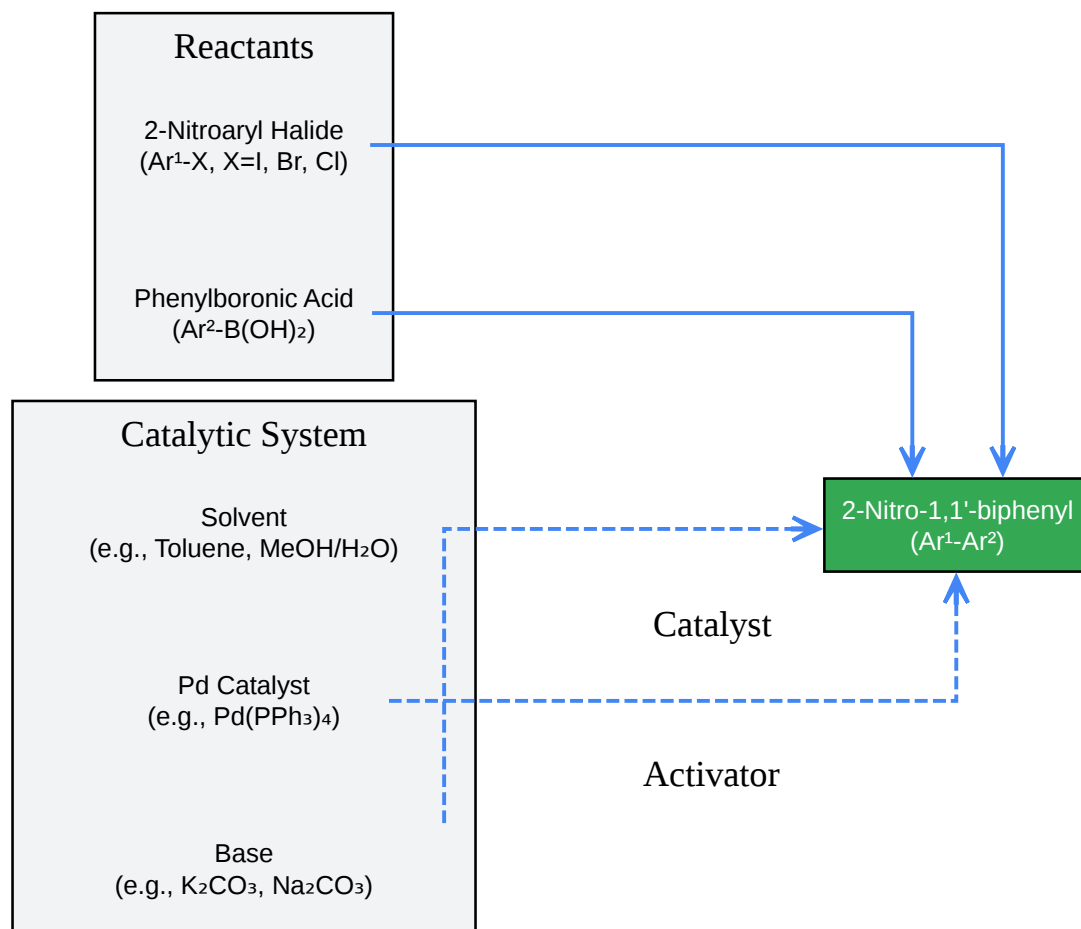

[Click to download full resolution via product page](#)

Caption: Suzuki-Miyaura Cross-Coupling for 2-Nitrobiphenyl Synthesis.

A noteworthy challenge arises when the phenylboronic acid itself is substituted with a nitro group at the 2-position, as obstacles in the transmetalation step can occur.[4][9]

## Ullmann Coupling: The Classic Copper-Mediated Synthesis

The Ullmann reaction is a classical method for forming aryl-aryl bonds, involving the copper-mediated coupling of two aryl halide molecules.[10] For synthesizing unsymmetrical 2-nitrobiphenyls, a variation using a 2-nitroaryl halide and another aromatic compound is

employed. The traditional approach requires high temperatures and often uses high-boiling polar solvents like DMF or nitrobenzene.[11][12]

Modern Advancements: To address the harsh conditions of the classic Ullmann reaction, more environmentally friendly, solvent-free methods have been developed. These include heating the neat reactants with copper powder or employing high-speed ball milling (HSBM).[10][13] The HSBM technique is particularly effective, as it uses a copper vial and ball bearing that provide a continuously fresh catalyst surface, often leading to quantitative yields without the need for extensive purification.[10]

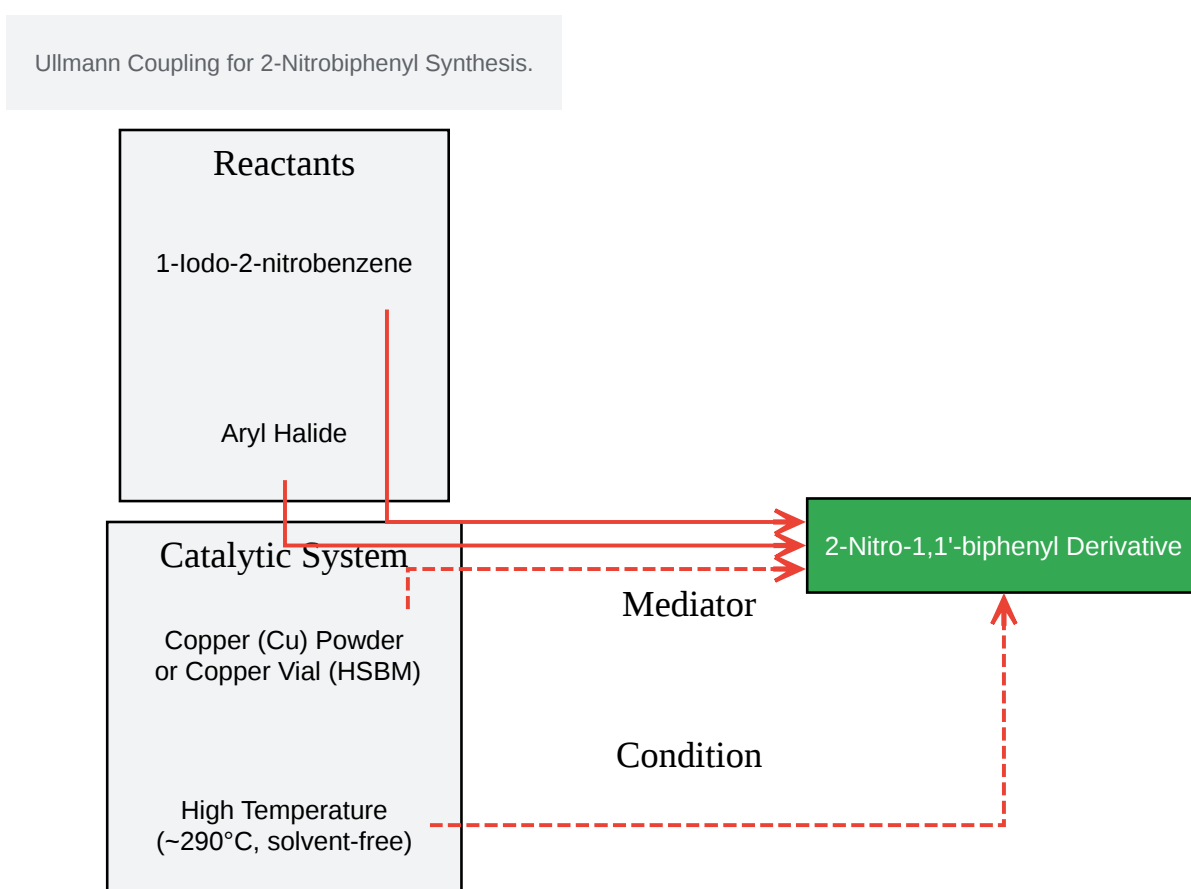

[Click to download full resolution via product page](#)

Caption: Ullmann Coupling for 2-Nitrobiphenyl Synthesis.

## Modern C-H Functionalization Strategies

Direct C-H bond activation and functionalization represent the cutting edge of synthetic chemistry, offering a more atom-economical approach by avoiding the pre-functionalization of substrates (e.g., into halides or boronic acids).[14][15] While less common for the direct synthesis of 2-nitrobiphenyls, methods for the functionalization of biphenyl scaffolds are rapidly advancing. For example, nitrile-directed meta-C-H olefination, acetoxylation, and iodination of biaryl compounds have been reported, showcasing the potential for regioselective modifications.[16] These advanced methods, often employing palladium catalysis, provide powerful tools for the late-stage diversification of biphenyl structures.[16]

Synthetic Method	Catalyst/Mediator	Typical Substrates	Advantages	Disadvantages	Reference(s)
Suzuki-Miyaura Coupling	Palladium (e.g., Pd(PPh <sub>3</sub> ) <sub>4</sub> )	2-Nitroaryl halides, Phenylboronic acids	High yields, excellent functional group tolerance, mild conditions.	Cost of palladium catalyst, potential issues with sterically hindered substrates.	<a href="#">[4]</a> <a href="#">[7]</a> <a href="#">[8]</a>
Ullmann Coupling	Copper (Cu)	2-Nitroaryl iodides/bromides	Cost-effective (uses copper), solvent-free options available (Green Chemistry).	Harsh reaction conditions (high temp), lower functional group tolerance, can have lower yields than Suzuki.	<a href="#">[10]</a> <a href="#">[12]</a> <a href="#">[13]</a>
C-H Functionalization	Palladium (Pd)	Biphenyls with directing groups	High atom economy, avoids pre-functionalization, allows late-stage modification.	Often requires specific directing groups, can have challenges with regioselectivity.	<a href="#">[15]</a> <a href="#">[16]</a>

## Part 2: Physicochemical Properties and Atropisomerism

2-Nitro-1,1'-biphenyl is typically a gold to tan crystalline solid at room temperature.[17][18] It is insoluble in water but soluble in many organic solvents.[19] The most significant stereochemical feature of many 2-nitro-1,1'-biphenyl derivatives is the potential for atropisomerism.

Atropisomerism: Chirality Without a Chiral Center

Atropisomerism occurs in molecules that have hindered rotation (a high rotational barrier) around a single bond, allowing for the isolation of distinct conformational isomers (rotamers).[2][20] In biphenyls, this phenomenon, also known as axial chirality, arises when there are bulky substituents at the ortho positions (2, 2', 6, and 6').[20][21]

The ortho-nitro group, along with other substituents on the adjacent ring, can create sufficient steric hindrance to prevent free rotation around the pivotal C1-C1' bond. If the substitution pattern on the rings is asymmetric, the molecule becomes chiral and can be resolved into stable, non-superimposable enantiomers.[21][22]

Caption: Hindered rotation in ortho-substituted biphenyls leads to stable atropisomers.

## Part 3: Key Reactions and Applications

The true value of 2-nitro-1,1'-biphenyls lies in their utility as versatile synthetic intermediates. The nitro group can be readily transformed into other functionalities, most notably through reduction to an amino group, which opens pathways to a vast array of complex molecules.[3][23]

### Gateway to Carbazoles: Reductive Cyclization

The most prominent application of 2-nitrobiphenyls is their conversion into carbazoles, a class of N-heterocycles found in numerous natural products and pharmacologically active compounds.[24][25] This transformation is achieved through reductive cyclization, where the nitro group is reduced, and the resulting intermediate undergoes an intramolecular cyclization to form the carbazole core.

Several methods exist for this cyclization:

- Triphenylphosphine-Mediated Cyclization (Cadogan Reaction): This is a practical and convenient method where triphenylphosphine acts as the deoxygenating agent to reduce the nitro group, facilitating cyclization. The reaction is typically carried out in a high-boiling solvent like o-dichlorobenzene and tolerates a wide range of functional groups.[24][26][27]
- Palladium-Catalyzed Reductive Cyclization: These methods often use carbon monoxide (CO) as the reductant. To avoid handling pressurized CO gas, CO surrogates like phenyl formate can be used, which decompose in situ to release CO.[25]

Reductive cyclization of 2-nitrobiphenyl to form the carbazole scaffold.

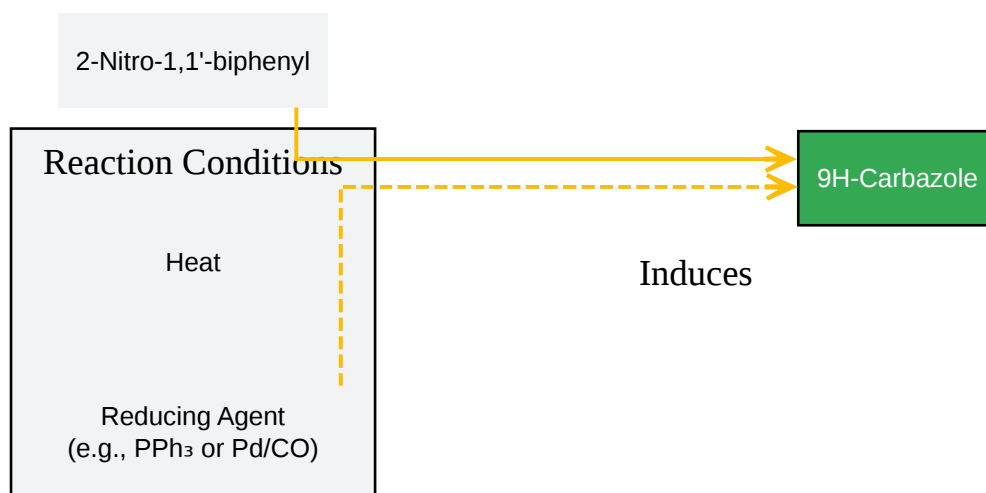

[Click to download full resolution via product page](#)

Caption: Reductive cyclization of 2-nitrobiphenyl to form the carbazole scaffold.

## Applications in Medicinal Chemistry and Materials Science

Beyond carbazoles, the 2-nitrobiphenyl moiety is a precursor to a wide range of bioactive molecules.[28] The reduction of the nitro group to an amine provides a key intermediate, 2-aminobiphenyl, which is a building block for various pharmaceuticals, including anti-inflammatory drugs and kinase inhibitors. The ability to introduce diverse substituents onto the biphenyl rings allows for the fine-tuning of a compound's biological activity and physical

properties, making these derivatives valuable in drug discovery and the development of organic materials.[1]

## Part 4: Experimental Protocols

The following protocols are generalized procedures derived from literature and should be adapted and optimized for specific substrates.

### Protocol 1: Synthesis of 2-Nitrobiphenyl via Suzuki Coupling[8]

This protocol describes a microwave-assisted Suzuki coupling of 1-chloro-2-nitrobenzene with phenylboronic acid.

- **Reactant Preparation:** To a microwave vial, add 1-chloro-2-nitrobenzene (1.0 mmol), phenylboronic acid (1.2 mmol), sodium carbonate (2.0 mmol), and Pd(PPh<sub>3</sub>)<sub>4</sub> (0.03 mmol).
- **Solvent Addition:** Add a 4:1 mixture of methanol and water (5 mL).
- **Reaction:** Seal the vial and place it in a microwave reactor. Heat the mixture to the desired temperature (e.g., 100-120 °C) for 15-30 minutes.
- **Workup:** After cooling, dilute the reaction mixture with water and extract with ethyl acetate (3 x 20 mL).
- **Purification:** Combine the organic layers, wash with brine, dry over anhydrous sodium sulfate, and concentrate under reduced pressure. Purify the crude product by column chromatography (silica gel, using a hexane/ethyl acetate gradient) to yield the pure 2-nitrobiphenyl.

### Protocol 2: Synthesis of a Carbazole via PPh<sub>3</sub>-Mediated Reductive Cyclization[27]

This protocol describes the conversion of a 2-nitrobiphenyl derivative to a carbazole.

- **Reactant Preparation:** In a round-bottom flask equipped with a reflux condenser, combine the 2-nitrobiphenyl derivative (1.0 mmol) and triphenylphosphine (2.5 mmol).

- Solvent Addition: Add 1,2-dichlorobenzene (o-DCB) (2 mL per mmol of the nitro compound) under a nitrogen atmosphere.
- Reaction: Heat the mixture to reflux with vigorous stirring. Monitor the reaction by TLC until the starting material is completely consumed.
- Workup: Cool the reaction to room temperature and remove the solvent under high vacuum.
- Purification: The crude residue can be purified directly by column chromatography. Alternatively, to remove the triphenylphosphine oxide byproduct, slurry the residue with ligroin to precipitate the oxide, filter, concentrate the filtrate, and then purify by column chromatography to yield the pure carbazole.

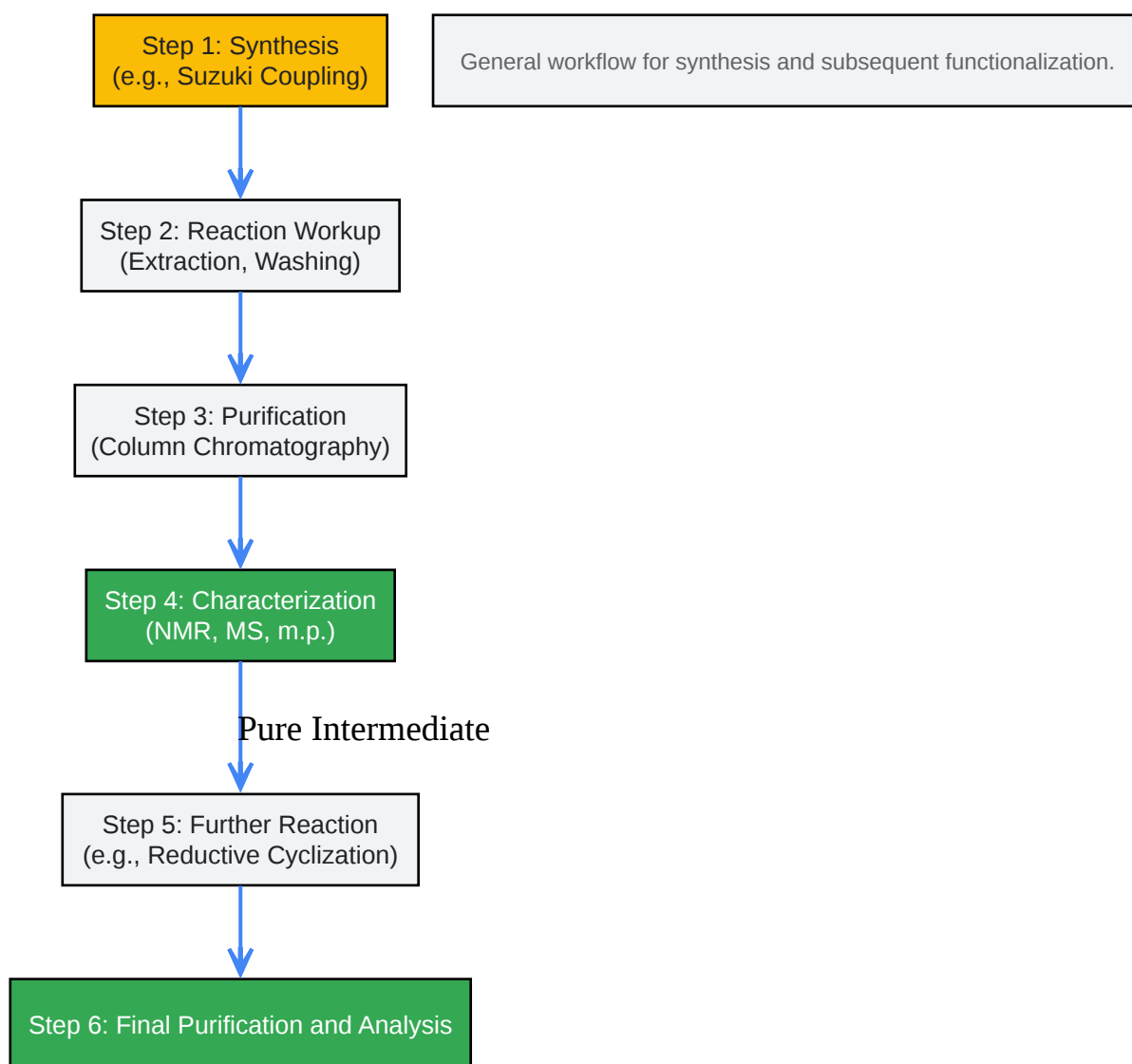

[Click to download full resolution via product page](#)

### Need Custom Synthesis?

BenchChem offers custom synthesis for rare earth carbides and specific isotopic labeling.

Email: [info@benchchem.com](mailto:info@benchchem.com) or [Request Quote Online](#).

## Sources

- 1. A fruitful century for the scalable synthesis and reactions of biphenyl derivatives: applications and biological aspects - RSC Advances (RSC Publishing) DOI:10.1039/D3RA03531J [pubs.rsc.org]
- 2. Stereo Isomerism in Biphenyl Compounds (Atropisomerism) and Conditions for Optical Activity | Pharmaguideline [pharmaguideline.com]
- 3. mdpi-res.com [mdpi-res.com]
- 4. pubs.acs.org [pubs.acs.org]
- 5. A fruitful century for the scalable synthesis and reactions of biphenyl derivatives: applications and biological aspects - PMC [pmc.ncbi.nlm.nih.gov]
- 6. pdf.benchchem.com [pdf.benchchem.com]
- 7. researchgate.net [researchgate.net]
- 8. researchgate.net [researchgate.net]
- 9. Synthesis of 2-nitro- and 2,2'-dinitrobiphenyls by means of the suzuki cross-coupling reaction - PubMed [pubmed.ncbi.nlm.nih.gov]
- 10. Synthesis of Substituted 2,2'-Dinitrobiphenyls by a Novel Solvent-Free High Yielding Ullmann Coupling Biarylation - PMC [pmc.ncbi.nlm.nih.gov]
- 11. CN106986774A - A kind of preparation method of 2 nitrobiphenyl - Google Patents [patents.google.com]
- 12. pdf.benchchem.com [pdf.benchchem.com]
- 13. rsc.org [rsc.org]
- 14. Metal-free radical catalysis: an sp<sup>2</sup> C–H activation strategy for efficient synthesis of lignin–biphenyl dimers - New Journal of Chemistry (RSC Publishing) [pubs.rsc.org]
- 15. fairlamb.group [fairlamb.group]

- 16. Rational Development of Remote C-H Functionalization of Biphenyl: Experimental and Computational Studies - PubMed [pubmed.ncbi.nlm.nih.gov]
- 17. 2-Nitrobiphenyl | C<sub>12</sub>H<sub>9</sub>NO<sub>2</sub> | CID 6829 - PubChem [pubchem.ncbi.nlm.nih.gov]
- 18. 2-Nitrobiphenyl - Hazardous Agents | Haz-Map [haz-map.com]
- 19. 2-NITRO-1,1'-BIPHENYL | CAMEO Chemicals | NOAA [cameochemicals.noaa.gov]
- 20. courseware.cutm.ac.in [courseware.cutm.ac.in]
- 21. Atropisomers: things are tight, single bond won't rotate – Chiralpedia [chiralpedia.com]
- 22. Biphenyl derivatives & Atropisomerism | PPTX [slideshare.net]
- 23. mdpi.com [mdpi.com]
- 24. Triphenylphosphine-mediated reductive cyclization of 2-nitrobiphenyls: a practical and convenient synthesis of carbazoles - PubMed [pubmed.ncbi.nlm.nih.gov]
- 25. air.unimi.it [air.unimi.it]
- 26. acs.figshare.com [acs.figshare.com]
- 27. pstorage-ac-6854636.s3.amazonaws.com [pstorage-ac-6854636.s3.amazonaws.com]
- 28. Recent Progress in the Synthesis of Drugs and Bioactive Molecules Incorporating Nitro(het)arene Core - PMC [pmc.ncbi.nlm.nih.gov]
- To cite this document: BenchChem. [Introduction: The Strategic Importance of the 2-Nitrobiphenyl Scaffold]. BenchChem, [2026]. [Online PDF]. Available at: [https://www.benchchem.com/product/b8436583/docs#introduction-the-strategic-importance-of-the-2-nitrobiphenyl-scaffold]

---

### Disclaimer & Data Validity:

The information provided in this document is for Research Use Only (RUO) and is strictly not intended for diagnostic or therapeutic procedures. While BenchChem strives to provide accurate protocols, we make no warranties, express or implied, regarding the fitness of this product for every specific experimental setup.

**Technical Support:** The protocols provided are for reference purposes. Unsure if this reagent suits your experiment?

**Need Industrial/Bulk Grade?** [Request Custom Synthesis Quote](#)

# BenchChem

Our mission is to be the trusted global source of essential and advanced chemicals, empowering scientists and researchers to drive progress in science and industry.

## Contact

Address: 3281 E Guasti Rd

Ontario, CA 91761, United States

Phone: (601) 213-4426

Email: [info@benchchem.com](mailto:info@benchchem.com)

[Contact our Ph.D. Support Team for a compatibility check](#)