

Application Notes and Protocols for Cadmium Selenide Quantum Dots in LED Applications

Author: BenchChem Technical Support Team. **Date:** May 2026

Compound of Interest

Compound Name: CADMIUM SELENIDE

Cat. No.: B8431935

[Get Quote](#)

For Researchers, Scientists, and Drug Development Professionals

Introduction

Cadmium Selenide (CdSe) quantum dots (QDs) are semiconductor nanocrystals that exhibit unique quantum mechanical properties due to their size, which is on the order of the exciton Bohr radius.[1] This quantum confinement effect allows for the precise tuning of their optical and electronic properties, most notably their photoluminescence and electroluminescence, by simply controlling the particle size.[2][3] Larger dots emit longer wavelengths (redder light), while smaller dots emit shorter wavelengths (bluer light).[3] This size-tunability, combined with their high photoluminescence quantum yield (PLQY), narrow emission spectra, and broad absorption, makes them highly desirable materials for next-generation light-emitting diode (LED) applications, including displays and solid-state lighting.[4][5]

This document provides detailed application notes, experimental protocols, and performance data for the utilization of CdSe-based quantum dots in LED technologies.

Core Concepts and Principles

The operation of a Quantum Dot LED (QD-LED) is analogous to that of a conventional organic light-emitting diode (OLED).[6] The device structure typically consists of a multi-layer stack that includes an anode, a hole injection layer (HIL), a hole transport layer (HTL), a layer of quantum dots as the emissive layer (EML), an electron transport layer (ETL), an electron injection layer (EIL), and a cathode.[5][7]

When a voltage is applied across the device, electrons and holes are injected from the cathode and anode, respectively. These charge carriers are transported through the ETL and HTL and subsequently recombine within the quantum dot layer. This recombination of an electron-hole pair (an exciton) results in the emission of a photon with an energy corresponding to the bandgap of the quantum dot.[6] The color of the emitted light is therefore determined by the size of the CdSe QDs in the emissive layer.[3]

To enhance the stability and luminescence efficiency, CdSe cores are often encapsulated with a wider bandgap semiconductor material, such as zinc sulfide (ZnS), to form a core/shell structure (e.g., CdSe/ZnS).[4][8] This shell passivates surface defects on the CdSe core, which can act as non-radiative recombination centers, thereby improving the quantum yield and protecting the core from environmental degradation.[2][9]

Quantitative Performance Data

The performance of CdSe-based QD-LEDs is evaluated based on several key metrics. The tables below summarize representative data from various studies.

Table 1: Optical Properties of CdSe-based Quantum Dots

Quantum Dot Composition	Emission Peak (nm)	Full Width at Half Maximum (FWHM) (nm)	Photoluminescence Quantum Yield (PLQY) (%)	Reference
CdSe	597 - 638	20 - 30	Up to 91.4% (with TBP)	[10]
CdSe/ZnS	500 - 650	20 - 30	>90%	[4][8]
CdZnSe/ZnSe	620 - 690	Narrow	Up to 50%	[11]
CdSe/CdS/ZnS (Green)	550	35	84%	[12]
CdSe/CdS/ZnS (Red)	609	-	77%	[12]

Table 2: Performance Metrics of CdSe-based QD-LEDs

Emissive Layer	Peak External Quantum Efficiency (EQE) (%)	Maximum Luminance (cd/m ²)	Color	Reference
CdSe/ZnS	16.3	89,150	Green	[13]
CdSe/ZnSe/ZnS eS	22.9	67,840 (maintains >90% EQE at 100,000)	Green	[13]
CdZnSe/ZnSe	6.8	-	Red	[11]
CdSe/ZnS (mCP doped)	3.3	10,651	-	[14]
Red Tandem QD-LED	23.1	-	Red	[5]
Green Tandem QD-LED	27.6	-	Green	[5]
Blue Tandem QD-LED	21.4	-	Blue	[5]

Experimental Protocols

Protocol 1: Synthesis of CdSe Core Quantum Dots (Hot-Injection Method)

This protocol is based on a common hot-injection synthesis method.[2][15] Warning: Cadmium and selenium compounds are toxic and should be handled in a fume hood with appropriate personal protective equipment.

Materials:

- Cadmium oxide (CdO)
- Oleic acid (OA)

- 1-Octadecene (ODE)
- Selenium (Se) powder
- Trioctylphosphine (TOP)
- Toluene
- Methanol
- Three-neck round-bottom flask, heating mantle, condenser, thermocouple, nitrogen inlet, syringes, and standard glassware.

Procedure:

- **Cadmium Precursor Preparation:** In a three-neck flask, combine CdO (e.g., 0.5 mmol), oleic acid (e.g., 3 ml), and 1-octadecene (e.g., 8 ml).
- Heat the mixture to ~100-120°C under vacuum for 30-60 minutes to remove water and oxygen.
- Switch to a nitrogen atmosphere and increase the temperature to ~250-300°C until the solution becomes clear and colorless, indicating the formation of the cadmium oleate complex.
- **Selenium Precursor Preparation:** In a separate vial inside a glovebox or fume hood, dissolve Se powder (e.g., 0.5 mmol) in TOP or a mixture of TOP and ODE.
- **Nucleation and Growth:** Rapidly inject the selenium precursor solution into the hot cadmium precursor solution. This will cause a rapid color change, indicating the nucleation of CdSe nanocrystals.
- The growth temperature is typically maintained lower than the injection temperature. The size of the quantum dots, and thus their emission color, is controlled by the reaction time and temperature. Aliquots can be taken at different time points to obtain QDs of various sizes.
- **Isolation and Purification:** To stop the reaction, cool the flask rapidly.

- Add an excess of a non-solvent like methanol to precipitate the QDs.
- Centrifuge the mixture to collect the QD precipitate.
- Discard the supernatant and re-disperse the QDs in a solvent such as toluene. Repeat the precipitation and re-dispersion steps 2-3 times to purify the quantum dots.
- Finally, disperse the purified CdSe QDs in a suitable solvent for storage and further use.

Protocol 2: Fabrication of a CdSe-based QD-LED

This protocol describes the fabrication of a typical QD-LED device using solution processing. [\[16\]](#)

Materials:

- Patterned Indium Tin Oxide (ITO) coated glass substrates (anode)
- Poly(3,4-ethylenedioxythiophene) polystyrene sulfonate (PEDOT:PSS) solution (HIL/HTL)
- Purified CdSe/ZnS quantum dots dispersed in a non-polar solvent (e.g., toluene)
- Electron transport layer material (e.g., Zinc Oxide (ZnO) nanoparticles or an organic material like TPBi)
- Metal for cathode (e.g., Aluminum)
- Spin coater
- Thermal evaporator
- Glovebox with an inert atmosphere

Procedure:

- **Substrate Preparation:** Clean the patterned ITO substrate sequentially with detergent, deionized water, acetone, and isopropanol in an ultrasonic bath. Dry the substrate with a nitrogen gun.

- Treat the ITO surface with oxygen plasma or UV-ozone to improve its work function and promote adhesion of the subsequent layer.[16]
- Hole Injection/Transport Layer Deposition: Spin-coat a thin layer of PEDOT:PSS onto the cleaned ITO substrate.
- Anneal the substrate at a specified temperature (e.g., 120-150°C) to remove residual solvent.
- Quantum Dot Emissive Layer Deposition: Transfer the substrate into a nitrogen-filled glovebox.
- Spin-coat the CdSe/ZnS QD solution onto the PEDOT:PSS layer. The concentration of the QD solution and the spin speed will determine the thickness and uniformity of the emissive layer.
- Anneal the substrate at a moderate temperature to evaporate the solvent.
- Electron Transport Layer Deposition: Deposit the ETL. If using ZnO nanoparticles, this can be done via spin-coating. If using a small molecule organic material, it is typically deposited via thermal evaporation.
- Cathode Deposition: Deposit the metal cathode (e.g., 100-150 nm of Aluminum) through a shadow mask using a thermal evaporator.[16]
- Encapsulation: To protect the device from oxygen and moisture, it should be encapsulated using a suitable sealant and a cover glass.

Visualizations

Workflow for CdSe QD-LED Fabrication

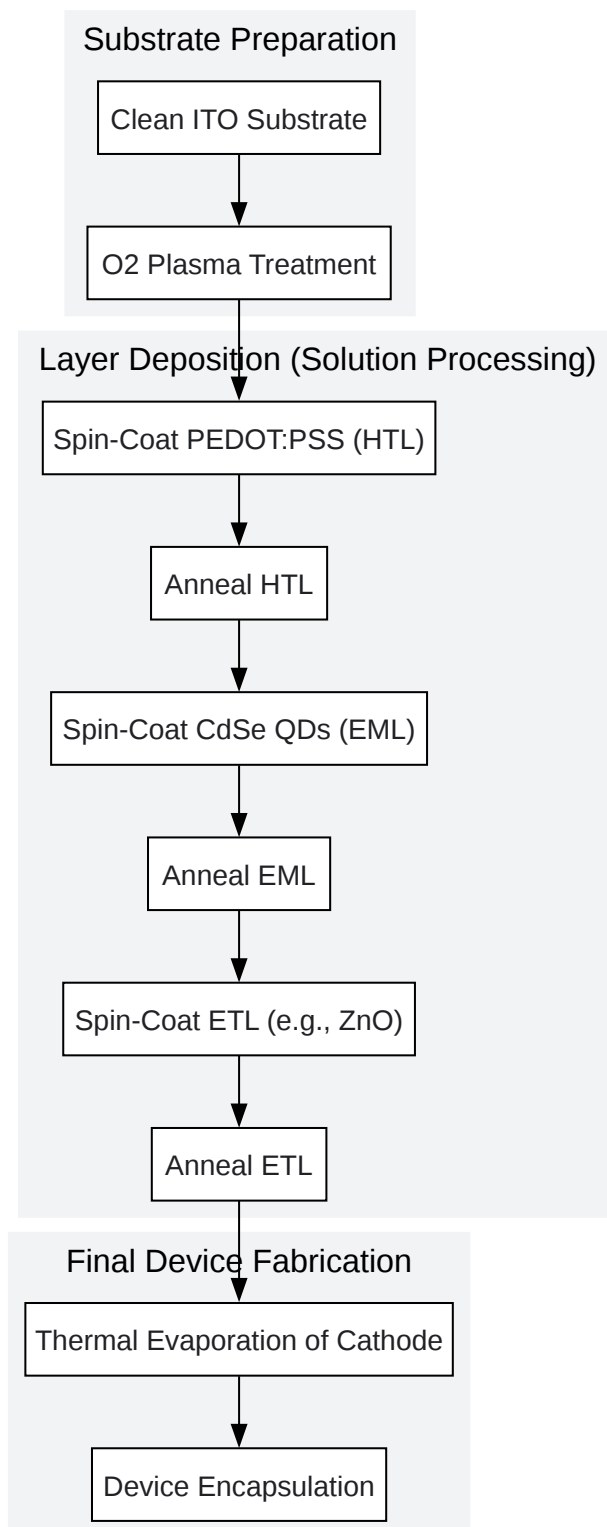

[Click to download full resolution via product page](#)

Caption: A flowchart illustrating the major steps in the fabrication of a solution-processed CdSe quantum dot LED.

Simplified Energy Level Diagram of a QD-LED

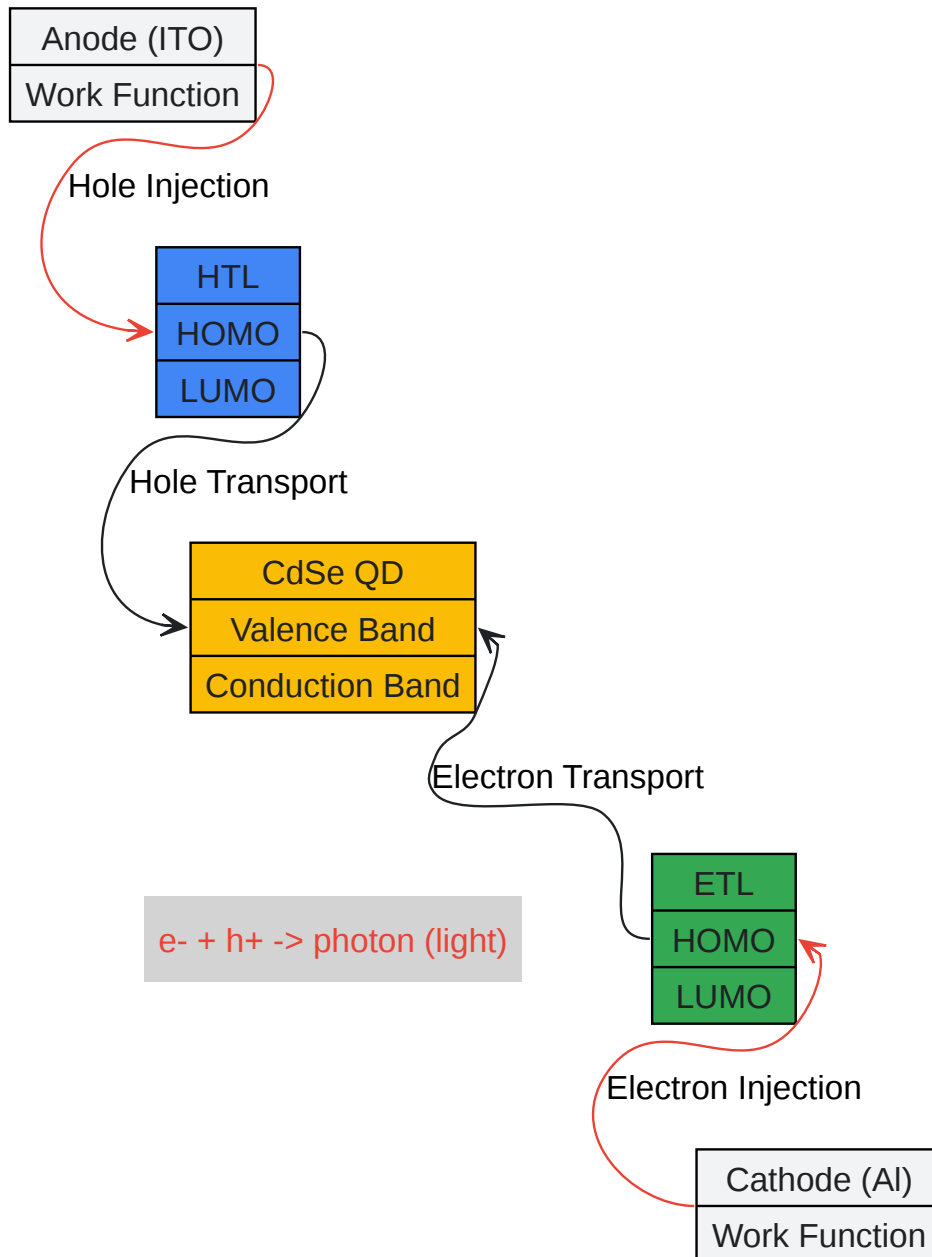

Structure of a Core/Shell CdSe/ZnS Quantum Dot

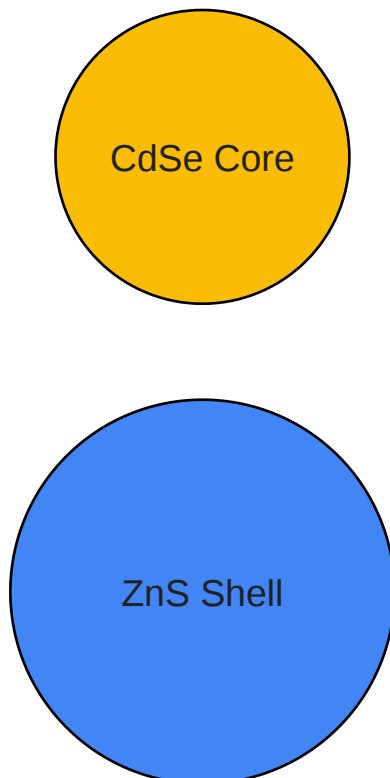

[Click to download full resolution via product page](#)

Need Custom Synthesis?

BenchChem offers custom synthesis for rare earth carbides and specific isotopic labeling.

Email: info@benchchem.com or [Request Quote Online](#).

References

- [1. zhao.chem.uconn.edu](http://1.zhao.chem.uconn.edu) [zhao.chem.uconn.edu]
- [2. youtube.com](http://2.youtube.com) [youtube.com]
- [3. google.com](http://3.google.com) [google.com]
- [4. nanographenex.com](http://4.nanographenex.com) [nanographenex.com]
- [5. Technology progress on quantum dot light-emitting diodes for next-generation displays - Nanoscale Horizons \(RSC Publishing\) DOI:10.1039/D0NH00556H](#) [pubs.rsc.org]
- [6. Quantum dot display - Wikipedia](#) [en.wikipedia.org]

- [7. Colloidal quantum dot light-emitting devices - PMC \[pmc.ncbi.nlm.nih.gov\]](#)
- [8. Quantum Dot LEDs: Making Custom Color LEDs : 5 Steps - Instructables \[instructables.com\]](#)
- [9. researchgate.net \[researchgate.net\]](#)
- [10. mdpi.com \[mdpi.com\]](#)
- [11. OPG \[opg.optica.org\]](#)
- [12. OPG \[opg.optica.org\]](#)
- [13. OPG \[opg.optica.org\]](#)
- [14. Enhanced Performance of CdSe/ZnS Quantum Dot Light-Emitting Diode...: Ingenta Connect \[ingentaconnect.com\]](#)
- [15. Synthesis of Cadmium Selenide Quantum Dot Nanoparticles – MRSEC Education Group – UW–Madison \[education.mrsec.wisc.edu\]](#)
- [16. Fabrication Process of Light Emitting Diodes Using CdSe/CdS/ZnS Quantum Dot - Proceedings of the Korean Vacuum Society Conference \[koreascience.kr\]](#)
- To cite this document: BenchChem. [Application Notes and Protocols for Cadmium Selenide Quantum Dots in LED Applications]. BenchChem, [2026]. [Online PDF]. Available at: [<https://www.benchchem.com/product/b8431935/docs#application-notes-and-protocols-for-cadmium-selenide-quantum-dots-in-led-applications>]

Disclaimer & Data Validity:

The information provided in this document is for Research Use Only (RUO) and is strictly not intended for diagnostic or therapeutic procedures. While BenchChem strives to provide accurate protocols, we make no warranties, express or implied, regarding the fitness of this product for every specific experimental setup.

Technical Support: The protocols provided are for reference purposes. Unsure if this reagent suits your experiment?

Need Industrial/Bulk Grade? [Request Custom Synthesis Quote](#)

BenchChem

Our mission is to be the trusted global source of essential and advanced chemicals, empowering scientists and researchers to drive progress in science and industry.

Contact

Address: 3281 E Guasti Rd

Ontario, CA 91761, United States

Phone: (601) 213-4426

Email: info@benchchem.com

[Contact our Ph.D. Support Team for a compatibility check](#)