

# Technical Support Center: (+)-Norgestrel Long-Term Storage and Stability

**Author:** BenchChem Technical Support Team. **Date:** April 2026

## Compound of Interest

Compound Name: (+)-Norgestrel

Cat. No.: B8389816

[Get Quote](#)

For Researchers, Scientists, and Drug Development Professionals

This technical support center provides comprehensive guidance on the challenges associated with the long-term storage and stability of **(+)-Norgestrel**. It includes troubleshooting guides for common experimental issues and frequently asked questions to support your research and development activities.

## Frequently Asked Questions (FAQs)

Q1: What are the primary factors that affect the stability of **(+)-Norgestrel**?

A1: The stability of **(+)-Norgestrel** is primarily influenced by temperature, humidity, light, and the presence of certain excipients.<sup>[1][2]</sup> High temperatures and humidity can accelerate degradation.<sup>[1]</sup> Exposure to light, particularly UV light, can also lead to the formation of degradation products.

Q2: What are the recommended storage conditions for **(+)-Norgestrel**?

A2: For long-term storage, **(+)-Norgestrel** should be kept at controlled room temperature, generally between 20°C to 25°C (68°F to 77°F), in a well-closed container, protected from light

and moisture.[3]

Q3: What are the known degradation pathways for **(+)-Norgestrel**?

A3: **(+)-Norgestrel** is susceptible to degradation through hydrolysis (acidic and alkaline conditions) and oxidation.[1] Forced degradation studies on its active enantiomer, levonorgestrel, have shown significant degradation under these conditions. Thermal and photolytic degradation also occur, though to a lesser extent under typical storage conditions.

Q4: Are there any known incompatibilities with common pharmaceutical excipients?

A4: Preformulation studies on levonorgestrel have indicated potential chemical interactions with magnesium stearate and aspartame, especially under heated conditions. No significant chemical interactions were observed with microcrystalline cellulose, lactose monohydrate, sodium carboxymethyl cellulose, calcium lactate pentahydrate, and talc at ambient temperature.[1] However, it is always recommended to conduct specific drug-excipient compatibility studies for your unique formulation.

Q5: How can I monitor the stability of my **(+)-Norgestrel** samples?

A5: A stability-indicating High-Performance Liquid Chromatography (HPLC) method is the most common and reliable way to monitor the stability of **(+)-Norgestrel**. This method should be able to separate the active pharmaceutical ingredient (API) from its degradation products and any excipients present in the formulation.

## Troubleshooting Guides

This section addresses specific issues you may encounter during the stability testing and analysis of **(+)-Norgestrel**.

### HPLC Analysis Troubleshooting

Issue	Possible Causes	Troubleshooting Steps
Peak Tailing of (+)-Norgestrel	<ul style="list-style-type: none"> <li>- Interaction with active silanols on the column.</li> <li>- Incorrect mobile phase pH.</li> <li>- Column contamination.</li> </ul>	<ul style="list-style-type: none"> <li>- Use a high-purity, end-capped C18 column.</li> <li>- Ensure the mobile phase pH is appropriate for the analysis (typically neutral for steroids).</li> <li>- Flush the column with a strong solvent like isopropanol.</li> </ul>
Peak Fronting of (+)-Norgestrel	<ul style="list-style-type: none"> <li>- Sample overload (mass or volume).</li> <li>- Sample solvent is stronger than the mobile phase.</li> <li>- Column collapse due to highly aqueous mobile phase.<sup>[4]</sup></li> </ul>	<ul style="list-style-type: none"> <li>- Reduce the injection volume or dilute the sample.<sup>[5]</sup></li> <li>- Dissolve the sample in the mobile phase.</li> <li>- If using a highly aqueous mobile phase, switch to an "aqueous C18" column or ensure the mobile phase contains at least 5-10% organic solvent.<sup>[4]</sup></li> </ul>
Appearance of New, Unknown Peaks	<ul style="list-style-type: none"> <li>- Formation of degradation products.</li> <li>- Contamination of the sample, solvent, or HPLC system.</li> </ul>	<ul style="list-style-type: none"> <li>- Compare the chromatogram with a reference standard stored under ideal conditions.</li> <li>- Perform forced degradation studies to tentatively identify the degradation products.</li> <li>- Check for sources of contamination in your sample preparation and analytical workflow.</li> </ul>
Shifting Retention Times	<ul style="list-style-type: none"> <li>- Change in mobile phase composition.</li> <li>- Fluctuation in column temperature.</li> <li>- Inconsistent flow rate.</li> </ul>	<ul style="list-style-type: none"> <li>- Prepare fresh mobile phase and ensure proper mixing and degassing.</li> <li>- Use a column oven to maintain a consistent temperature.<sup>[6]</sup></li> <li>- Check the HPLC pump for leaks or bubbles.</li> </ul>

## Stability Study Troubleshooting

Issue	Possible Causes	Troubleshooting Steps
Unexpectedly High Degradation at Accelerated Conditions (e.g., 40°C/75% RH)	<ul style="list-style-type: none"> <li>- High moisture permeability of the packaging.</li> <li>- Incompatibility with an excipient, exacerbated by heat and humidity.</li> <li>- The formulation is inherently sensitive to these conditions.</li> </ul>	<ul style="list-style-type: none"> <li>- Evaluate the container closure system for its moisture barrier properties.</li> <li>- Review drug-excipient compatibility data. Consider screening alternative excipients.</li> <li>- Reformulate with protective excipients or a more robust formulation design.</li> </ul>
Discoloration or Change in Physical Appearance	<ul style="list-style-type: none"> <li>- Formation of chromophoric degradation products.</li> <li>- Interaction with packaging components.</li> <li>- Physical changes in excipients (e.g., Maillard reaction with lactose).</li> </ul>	<ul style="list-style-type: none"> <li>- Characterize the degradation products to identify the cause.</li> <li>- Conduct compatibility studies with the packaging materials.</li> <li>- If using reducing sugars like lactose, consider alternative fillers, especially if the API or other excipients contain amine groups.</li> </ul>
Failure to Meet Dissolution Specifications Over Time	<ul style="list-style-type: none"> <li>- Physical changes in the tablet (e.g., hardening).</li> <li>- Cross-linking of excipients.</li> <li>- Changes in the crystal form of the API.</li> </ul>	<ul style="list-style-type: none"> <li>- Monitor tablet hardness and friability during the stability study.</li> <li>- Investigate potential interactions between excipients that could lead to cross-linking.</li> <li>- Use techniques like XRPD to monitor the solid-state properties of (+)-Norgestrel in the formulation.</li> </ul>

## Data Presentation

The following table summarizes quantitative data from forced degradation studies on levonorgestrel, the active enantiomer of **(+)-Norgestrel**. This data can help in understanding the potential degradation under various stress conditions.

Table 1: Summary of Forced Degradation Data for Levonorgestrel

Stress Condition	Duration	Approximate Degradation (%)	Reference
Acid Hydrolysis (1N HCl)	7 hours at 100°C	31.52%	[1]
Alkaline Hydrolysis (0.5N NaOH)	7 hours at 100°C	68.31%	[1]
Oxidation (10% H <sub>2</sub> O <sub>2</sub> )	7 hours at 100°C	43.14%	[1]
Thermal Degradation	7 days at 100°C	Minimal	[1]
Photolytic Degradation (UV light)	7 days	Minimal	[1]

## Experimental Protocols

### Protocol 1: Forced Degradation Study of (+)-Norgestrel

Objective: To investigate the degradation pathways of **(+)-Norgestrel** under various stress conditions as part of the development of a stability-indicating analytical method.

Methodology:

- Preparation of Stock Solution: Prepare a stock solution of **(+)-Norgestrel** in a suitable solvent (e.g., methanol or acetonitrile) at a concentration of approximately 1 mg/mL.
- Acid Hydrolysis:
  - Mix 1 mL of the stock solution with 1 mL of 1N HCl.
  - Heat the mixture at 80°C for 4 hours.
  - Cool the solution to room temperature and neutralize with 1N NaOH.
  - Dilute to a final concentration of approximately 100 µg/mL with the mobile phase.

- Alkaline Hydrolysis:
  - Mix 1 mL of the stock solution with 1 mL of 0.5N NaOH.
  - Heat the mixture at 80°C for 4 hours.
  - Cool the solution to room temperature and neutralize with 1N HCl.
  - Dilute to a final concentration of approximately 100 µg/mL with the mobile phase.
- Oxidative Degradation:
  - Mix 1 mL of the stock solution with 1 mL of 10% hydrogen peroxide (H<sub>2</sub>O<sub>2</sub>).
  - Keep the solution at room temperature for 24 hours.
  - Dilute to a final concentration of approximately 100 µg/mL with the mobile phase.
- Thermal Degradation:
  - Store a solid sample of **(+)-Norgestrel** in a hot air oven at 105°C for 24 hours.
  - After exposure, prepare a solution of approximately 100 µg/mL in the mobile phase.
- Photolytic Degradation:
  - Expose a solid sample of **(+)-Norgestrel** to UV light (254 nm) in a photostability chamber for 7 days.
  - After exposure, prepare a solution of approximately 100 µg/mL in the mobile phase.
- Analysis: Analyze all stressed samples, along with an unstressed control sample, using a validated stability-indicating HPLC method.

## Protocol 2: Stability-Indicating HPLC Method for (+)-Norgestrel

Objective: To quantify **(+)-Norgestrel** and its degradation products in stability samples.

**Methodology:**

- HPLC System: A standard HPLC system with a UV detector.
- Column: Kromasil C18 (250 mm x 4.6 mm, 5 µm) or equivalent.
- Mobile Phase: A gradient of water (A) and acetonitrile (B).
- Gradient Program:
  - 0-5 min: 50% B
  - 5-20 min: 50% to 80% B
  - 20-25 min: 80% B
  - 25-30 min: 80% to 50% B
  - 30-35 min: 50% B
- Flow Rate: 1.0 mL/min.
- Column Temperature: 25°C.
- Detection Wavelength: 241 nm.
- Injection Volume: 20 µL.
- Sample Preparation: Dilute the sample to an appropriate concentration (e.g., 100 µg/mL) using the mobile phase.

## Visualizations

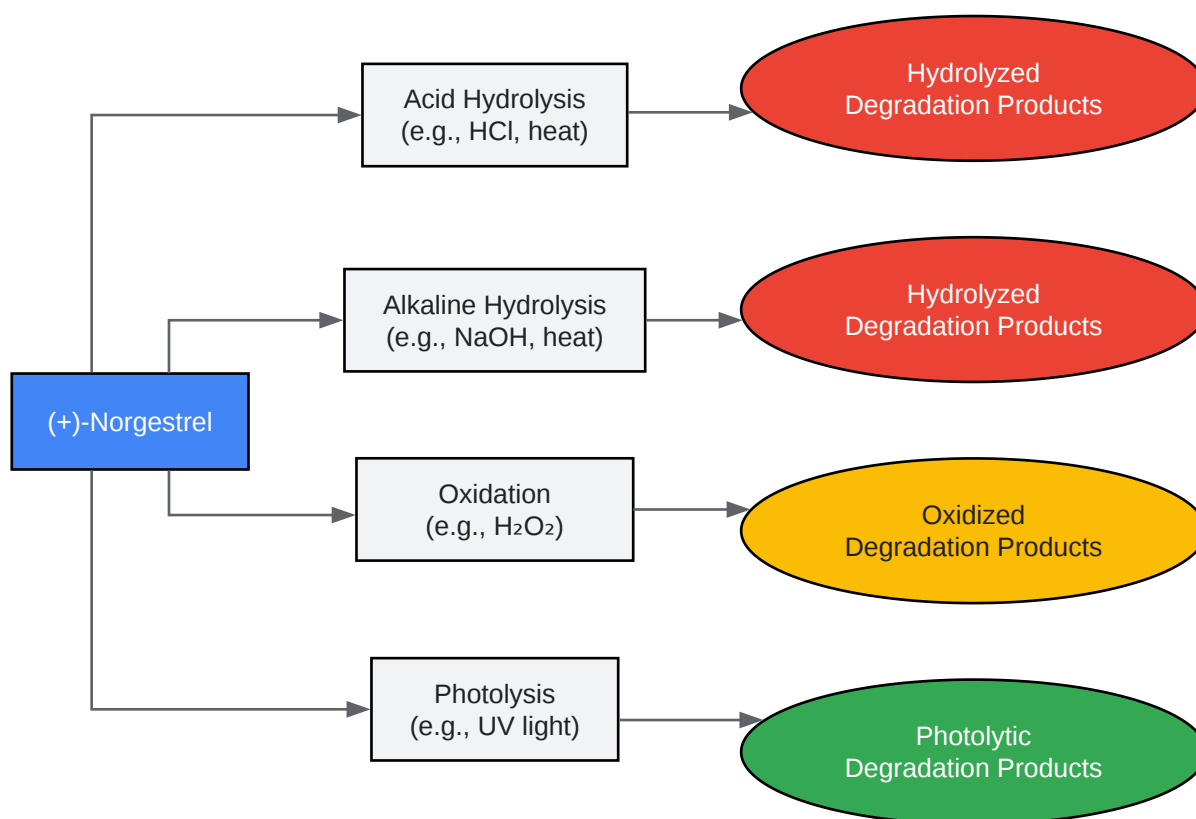

[Click to download full resolution via product page](#)

Caption: Major degradation pathways of **(+)-Norgestrel** under stress conditions.

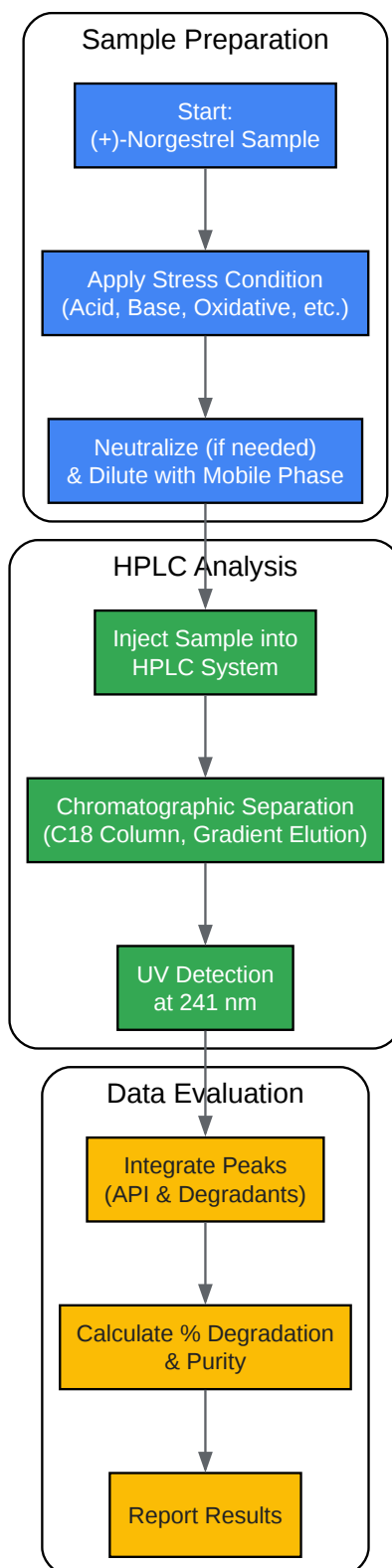

[Click to download full resolution via product page](#)

Caption: Experimental workflow for a forced degradation study of **(+)-Norgestrel**.

**Need Custom Synthesis?**

BenchChem offers custom synthesis for rare earth carbides and specific isotopic labeling.

Email: [info@benchchem.com](mailto:info@benchchem.com) or [Request Quote Online](#).

## References

- [1. researchgate.net \[researchgate.net\]](https://www.researchgate.net)
- [2. mdpi.com \[mdpi.com\]](https://www.mdpi.com)
- [3. accessdata.fda.gov \[accessdata.fda.gov\]](https://accessdata.fda.gov)
- [4. \[4\]Troubleshooting HPLC- Fronting Peaks \[restek.com\]](#)
- [5. Understanding Peak Fronting in HPLC | Phenomenex \[phenomenex.com\]](#)
- [6. Troubleshooting and Performance Improvement for HPLC | Aurigene Pharmaceutical Services \[aurigeneservices.com\]](#)
- To cite this document: BenchChem. [Technical Support Center: (+)-Norgestrel Long-Term Storage and Stability]. BenchChem, [2026]. [Online PDF]. Available at: [\[https://www.benchchem.com/product/b8389816/docs#technical-support-center-norgestrel-long-term-storage-and-stability\]](https://www.benchchem.com/product/b8389816/docs#technical-support-center-norgestrel-long-term-storage-and-stability)

---

**Disclaimer & Data Validity:**

The information provided in this document is for Research Use Only (RUO) and is strictly not intended for diagnostic or therapeutic procedures. While BenchChem strives to provide accurate protocols, we make no warranties, express or implied, regarding the fitness of this product for every specific experimental setup.

**Technical Support:** The protocols provided are for reference purposes. Unsure if this reagent suits your experiment?

**Need Industrial/Bulk Grade?** [Request Custom Synthesis Quote](#)

# BenchChem

Our mission is to be the trusted global source of essential and advanced chemicals, empowering scientists and researchers to drive progress in science and industry.

## Contact

Address: 3281 E Guasti Rd

Ontario, CA 91761, United States

Phone: (601) 213-4426

Email: [info@benchchem.com](mailto:info@benchchem.com)

[Contact our Ph.D. Support Team for a compatibility check](#)