

IR Spectroscopy Characterization Guide: 1-(2,2,2-Trifluoroethyl)piperidine[1]

Author: BenchChem Technical Support Team. **Date:** April 2026

Compound of Interest

Compound Name: 1-(2,2,2-Trifluoroethyl)piperidine

Cat. No.: B8377376

[Get Quote](#)

Content Type: Technical Comparison & Characterization Guide Target Audience: Medicinal Chemists, Process Development Scientists, and Analytical Chemists.[1]

Executive Summary & Scientific Context

1-(2,2,2-Trifluoroethyl)piperidine (CAS: 13105-50-5) is a critical fluorinated building block in medicinal chemistry.[1] The introduction of the trifluoroethyl group (ngcontent-ng-c3932382896="" _nghost-ng-c102404335="" class="inline ng-star-inserted">

) modulates basicity (

), lipophilicity (

), and metabolic stability compared to the non-fluorinated ethyl analog.

This guide provides a comparative infrared (IR) spectroscopy analysis to validate the synthesis of this target from its precursor, piperidine.[1] Because the trifluoroethyl group exerts a strong electron-withdrawing inductive effect (ngcontent-ng-c3932382896="" _nghost-ng-c102404335="" class="inline ng-star-inserted">

), the IR spectrum exhibits distinct diagnostic shifts—specifically in the C–H stretching region (Bohlmann bands) and the fingerprint region (C–F stretching)—that distinguish it from simple alkyl piperidines.

Structural Analysis & Vibrational Modes[1][2][3]

To accurately interpret the spectrum, one must visualize the molecule as two distinct vibrational domains: the piperidine ring and the fluoroalkyl tail.

Molecular Topology & Key Vibrations (Graphviz)

The following diagram maps the structural components to their expected vibrational frequencies.

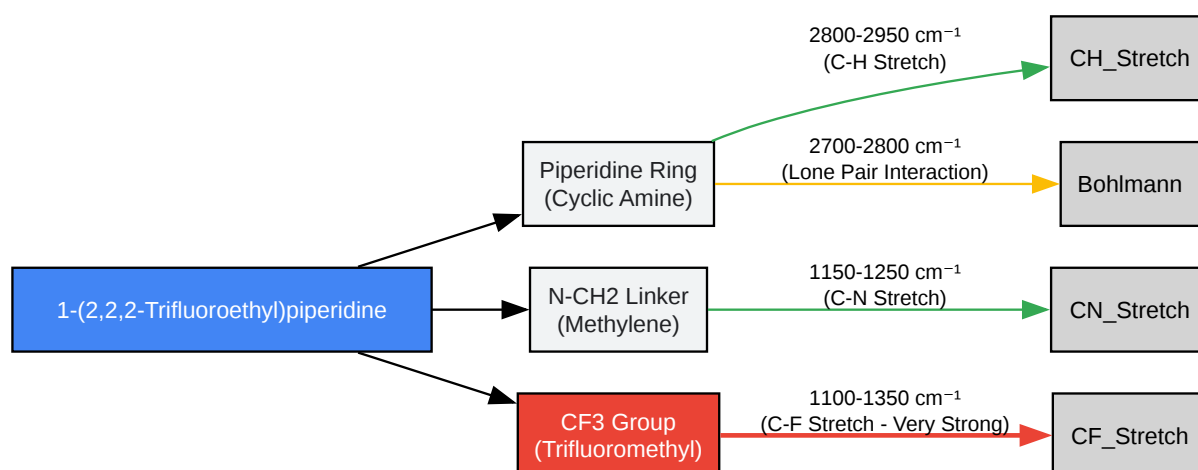

[Click to download full resolution via product page](#)

Figure 1: Structural decomposition of vibrational modes.[1] Note the dominance of the C–F stretch in the fingerprint region.

Comparative Spectral Analysis: Target vs. Precursor

The most effective way to confirm the identity of **1-(2,2,2-Trifluoroethyl)piperidine** is by comparing it against the starting material, piperidine.[1] The reaction involves N-alkylation, replacing the N–H bond with an N–C bond.

Diagnostic Peak Table[1]

Vibrational Mode	Piperidine (Precursor)	1-(2,2,2-Trifluoroethyl)piperidine (Target)	Diagnostic Value
N-H Stretch	3200–3400 cm ⁻¹ (Broad, Medium)	ABSENT	Primary Confirmation. Disappearance confirms N-alkylation.
C-H Stretch (Asym)	2930–2950 cm ⁻¹	2930–2960 cm ⁻¹	Low.[1] Standard aliphatic backbone.[1]
Bohlmann Bands	~2790 cm ⁻¹ (Distinct)	Attenuated / Shifted	High. The electron-withdrawing trifluoroethyl group reduces lone-pair donation, weakening these bands.
C-F Stretch	ABSENT	1100–1350 cm ⁻¹ (Very Strong, Multi-peak)	Critical. Confirms incorporation of the trifluoroethyl group.[1]
C-N Stretch	1100–1200 cm ⁻¹ (Weak/Medium)	1150–1250 cm ⁻¹ (Overlaps with C-F)	Medium.[1] Hard to distinguish due to C-F dominance.[1]

Detailed Band Interpretation

A. The "Fingerprint of Fluorine" (1100–1350 cm⁻¹)

The C–F bond is one of the strongest single bonds in organic chemistry, with a large dipole moment.

- Observation: You will observe intense, broad absorption bands in this region.[1]

- Differentiation: Unlike simple alkyl piperidines (which have moderate C–C and C–N bands here), the fluorinated target will show massive absorbance that often "bottoms out" the transmittance scale.^[1]
- Assignment: These are coupled vibrations of the

group (symmetric and asymmetric stretching).

B. The Bohlmann Band Anomaly (2700–2800 cm⁻¹)

In tertiary amines like N-ethylpiperidine, "Bohlmann bands" appear low-frequency C–H stretches (2700–2800 cm⁻¹).^[1] These occur when C–H bonds are anti-periplanar to the nitrogen lone pair, allowing hyperconjugation (ngcontent-ng-c3932382896="" _ngghost-ng-c102404335="" class="inline ng-star-inserted">

).

- Effect of Fluorine: The ngcontent-ng-c3932382896="" _ngghost-ng-c102404335="" class="inline ng-star-inserted">

group is strongly electron-withdrawing. It pulls electron density away from the nitrogen, reducing the energy of the lone pair and its ability to participate in hyperconjugation.

- Result: Expect the Bohlmann bands to be weaker or less defined in **1-(2,2,2-Trifluoroethyl)piperidine** compared to N-ethylpiperidine.^[1] This is a subtle but sophisticated proof of structure.^[1]

Experimental Protocol: ATR-FTIR Characterization

This protocol ensures high-quality data acquisition, minimizing atmospheric interference (water/CO₂) which can obscure key regions.^[1]

Workflow Diagram

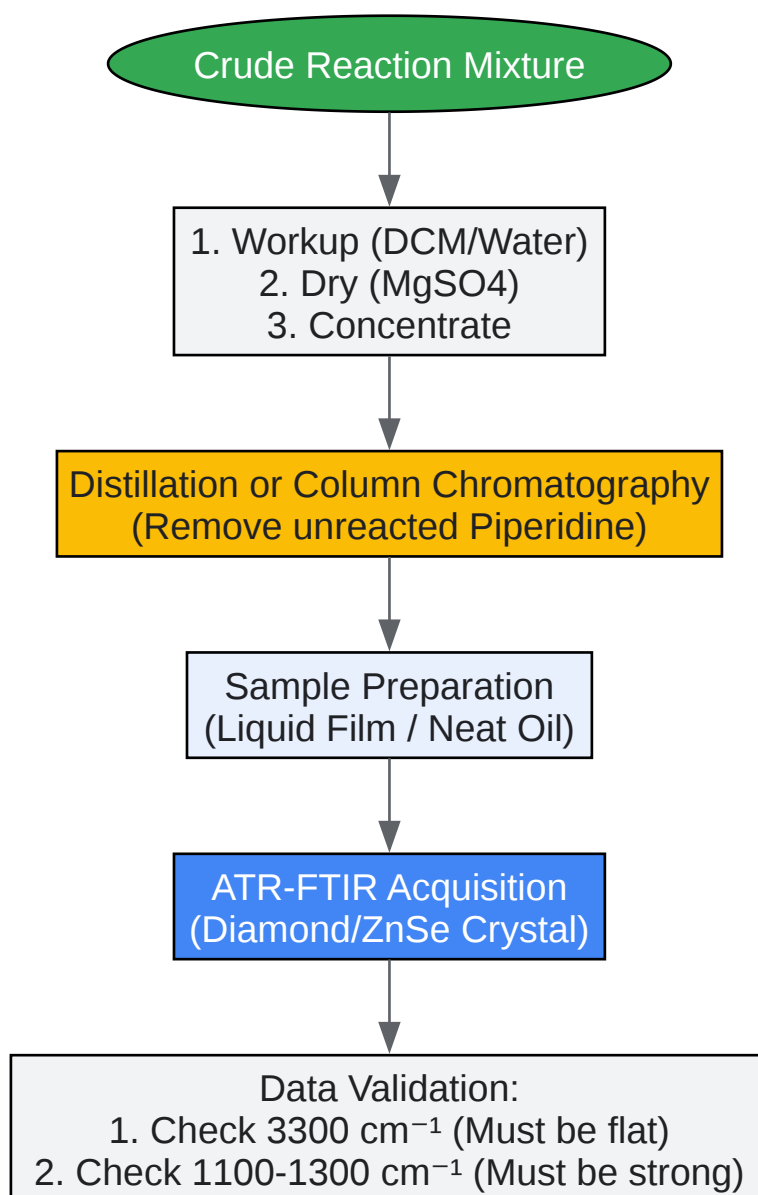

[Click to download full resolution via product page](#)

Figure 2: Standard workflow for isolation and spectral validation.[1]

Step-by-Step Methodology

- Instrument Setup:
 - Mode: Attenuated Total Reflectance (ATR) is preferred over transmission (KBr pellets) for liquid amines to avoid hygroscopic effects.[1]
 - Crystal: Diamond or ZnSe (Zinc Selenide).[1]

- Resolution: 4 cm^{-1} .[\[1\]](#)[\[2\]](#)[\[3\]](#)
- Scans: Minimum 16 scans (32 recommended for high signal-to-noise).
- Background Correction:
 - Clean the crystal with isopropanol.[\[1\]](#)
 - Collect an air background spectrum immediately before the sample.[\[1\]](#) Crucial: Ensure the background is free of water vapor peaks (3600 cm^{-1} and 1600 cm^{-1}).[\[1\]](#)
- Sample Application:
 - Place 1 drop ($\sim 10\text{-}20\text{ }\mu\text{L}$) of the neat liquid **1-(2,2,2-Trifluoroethyl)piperidine** onto the crystal.[\[1\]](#)
 - Apply pressure using the anvil to ensure intimate contact.[\[1\]](#)
- Data Processing:
 - Apply baseline correction if the baseline drifts.[\[1\]](#)
 - Normalization: Normalize the strongest peak (likely the C–F stretch at $\sim 1150\text{-}1200\text{ cm}^{-1}$) to 1.0 absorbance units for easy comparison.

Troubleshooting & Impurities

Spectral Anomaly	Probable Cause	Corrective Action
Peak at $\sim 3300\text{ cm}^{-1}$	Residual Piperidine (Starting Material) or Water	Dry sample over molecular sieves.[1] If peak persists, re-purify (distillation).[1]
Peak at $\sim 1700\text{ cm}^{-1}$	Residual Carbonyl Impurity	If reductive amination was used (using trifluoroacetaldehyde), this indicates unreacted aldehyde.[1]
Weak C-F Region	Poor Crystal Contact	Increase pressure on the ATR anvil.[1]
Doublet at 2300 cm^{-1}	Atmospheric CO_2	Re-run background scan; purge instrument with .

References

- Piperidine Reference Spectrum: NIST Mass Spectrometry Data Center.[1] Piperidine - Infrared Spectrum.[1][4][2][5][6] NIST Standard Reference Database 69: NIST Chemistry WebBook.[1][2] [Link]
- Bohlmann Bands: Konno, T., et al. "Stereo-electronic effects in the infrared spectra of amines." [1] Journal of the American Chemical Society.[1]
- General IR Interpretation: Silverstein, R. M., Webster, F. X., & Kiemle, D. J. (2005).[1] Spectrometric Identification of Organic Compounds (7th ed.). John Wiley & Sons.[1][7]
- C-F Stretching Frequencies: Socrates, G. (2001).[1] Infrared and Raman Characteristic Group Frequencies: Tables and Charts (3rd ed.). Wiley.[1][7] (See section on Fluorinated Compounds, typically $1000\text{--}1400\text{ cm}^{-1}$).[1][6]

Need Custom Synthesis?

BenchChem offers custom synthesis for rare earth carbides and specific isotopic labeling.

Email: info@benchchem.com or [Request Quote Online](#).

Sources

- 1. 1-(2,2,2-Trifluoroethyl)piperazine dihydrochloride | C₆H₁₃Cl₂F₃N₂ | CID 16312067 - PubChem [pubchem.ncbi.nlm.nih.gov]
- 2. Piperidine [webbook.nist.gov]
- 3. [researchgate.net](https://www.researchgate.net) [[researchgate.net](https://www.researchgate.net)]
- 4. Molecular structure, vibrational spectra (FTIR and FT Raman) and natural bond orbital analysis of 4-Aminomethylpiperidine: DFT study - PubMed [pubmed.ncbi.nlm.nih.gov]
- 5. Piperidine(110-89-4) IR Spectrum [[chemicalbook.com](https://www.chemicalbook.com)]
- 6. cpb-us-e1.wpmucdn.com [cpb-us-e1.wpmucdn.com]
- 7. Infrared spectroscopy correlation table - Wikipedia [en.wikipedia.org]
- To cite this document: BenchChem. [IR Spectroscopy Characterization Guide: 1-(2,2,2-Trifluoroethyl)piperidine[1]]. BenchChem, [2026]. [Online PDF]. Available at: [<https://www.benchchem.com/product/b8377376/docs#ir-spectroscopy-characterization-guide-1-2-2-2-trifluoroethyl-piperidine-1>]

Disclaimer & Data Validity:

The information provided in this document is for Research Use Only (RUO) and is strictly not intended for diagnostic or therapeutic procedures. While BenchChem strives to provide accurate protocols, we make no warranties, express or implied, regarding the fitness of this product for every specific experimental setup.

Technical Support: The protocols provided are for reference purposes. Unsure if this reagent suits your experiment?

Need Industrial/Bulk Grade? [Request Custom Synthesis Quote](#)

BenchChem

Our mission is to be the trusted global source of essential and advanced chemicals, empowering scientists and researchers to drive progress in science and industry.

Contact

Address: 3281 E Guasti Rd

Ontario, CA 91761, United States

Phone: (601) 213-4426

Email: info@benchchem.com

[Contact our Ph.D. Support Team for a compatibility check](#)