

Comparative analysis of the stability of different anthracene-based emitters

Author: BenchChem Technical Support Team. **Date:** April 2026

Compound of Interest

Compound Name: 9-(4-Tert-butylphenyl)anthracene

Cat. No.: B8307509

[Get Quote](#)

Comparative Analysis of the Stability of Anthracene-Based Emitters

Executive Summary: The Blue Stability Bottleneck

While red and green phosphorescent OLEDs have achieved commercial maturity, stable deep-blue emission remains the primary bottleneck. Anthracene derivatives are the industry standard for the blue Emissive Layer (EML) due to their high photoluminescence quantum yield (PLQY) and wide bandgap. However, their operational lifetime is limited by specific degradation mechanisms.

This guide compares the stability profiles of standard anthracene derivatives (ADN, MADN, TBADN) against next-generation stabilized variants (Deuterated, Sterically Hindered), providing experimental data and mechanistic insights to guide material selection.

Mechanistic Analysis of Stability

To select the right emitter, one must understand why they fail. The degradation of anthracene cores is rarely thermal decomposition alone; it is primarily driven by excited-state chemistry and polaron instabilities.

Degradation Pathways

- Exciton-Polaron Annihilation: High densities of triplets and polarons lead to energy transfer events that excite molecules to unstable higher-lying states (or), causing bond dissociation.
- Chemical Reactivity (Dimerization): The 9,10-positions of anthracene are chemically active. Without steric protection, excited-state anthracenes can undergo [4+4] cycloaddition (dimerization), breaking the conjugation and acting as deep traps/quenchers.
- C-H Bond Dissociation: The C-H bonds, particularly on the pendant aryl groups, are vulnerable to cleavage, leading to radical formation and subsequent non-radiative recombination centers.

Visualization: Degradation vs. Stabilization Logic

The following diagram maps the degradation pathways and the specific countermeasures used in modern derivative design.

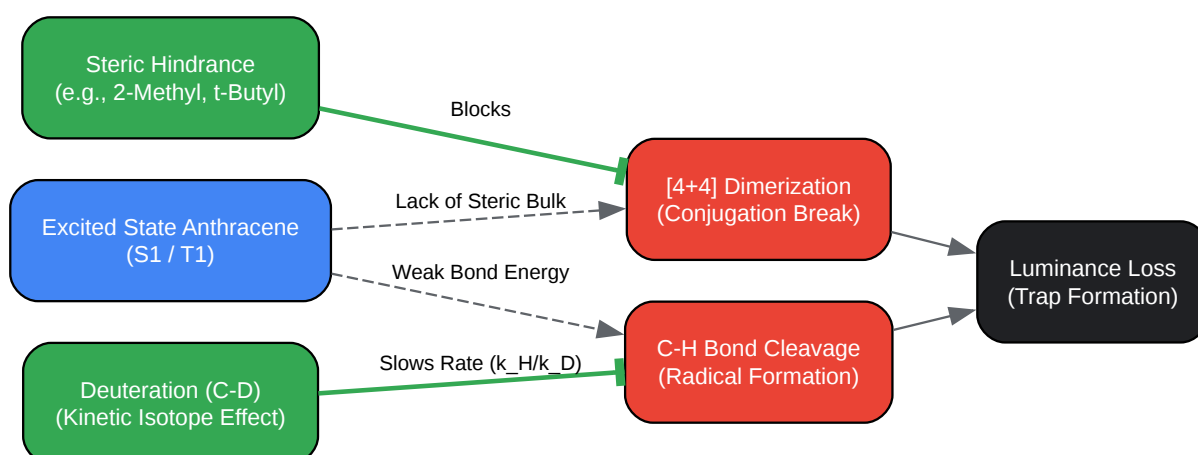

[Click to download full resolution via product page](#)

Figure 1: Mechanistic pathway showing how steric bulk prevents dimerization and deuterium mitigates bond cleavage.[1][3][4][5]

Comparative Performance Analysis

The following data synthesizes performance metrics from standard vacuum-deposited blue OLED devices. Note that "Host" materials often dictate the stability of the blue pixel, even when doped.

Structural & Thermal Stability

High glass transition temperatures (

) are a prerequisite for operational stability to prevent morphological crystallization during operation (Joule heating).

Material	Full Name	Substitution Strategy	(°C)	(°C)	Stability Insight
ADN	9,10-di(2-naphthyl)anthracene	Symmetric Aryl	~90-100	400+	Baseline standard. Prone to crystallization over long periods.
MADN	2-methyl-9,10-di(2-naphthyl)anthracene	Methyl Steric	~120	410+	Methyl group disrupts packing, increasing and film stability [1].
TBADN	2-t-butyl-9,10-di(2-naphthyl)anthracene	Bulky Steric	~130	420+	Bulky t-butyl group maximizes amorphous stability but can reduce charge mobility.
BDDFA	9,10-bis(fluorenyl)anthracene	Rigid Fluorenyl	131+	450+	Rigid fluorene wings prevent planar stacking, significantly boosting thermal limits [2].

Device Operational Stability (Lifetime Data)

Comparison of device lifetimes (

or

) under accelerated testing conditions.

Emitter/Host System	Dopant	CIE (x,y)	EQE Max (%)	Lifetime ()	Relative Stability Factor
ADN (Ref)	TBP	(0.14, 0.16)	3.5 - 5.0	~100h @ 1000 nits	1.0x (Baseline)
MADN	TBP	(0.14, 0.15)	5.0 - 6.0	~600h @ 20 mA/cm ²	~6.0x vs ADN [1]
Deuterated ADN	D-TBP	(0.14, 0.16)	5.0 - 5.5	~800h @ 1000 nits	~8.0x vs Non-D [3]
Phosphine-Oxide Anthracene	None	(0.13, 0.12)	5.5	540h ()	High stability due to bipolar transport balance [4].

Key Takeaway:

- MADN vs. ADN:** The addition of a methyl group at the 2-position (MADN) does not just improve thermal properties; it significantly enhances operational lifetime by preventing the close stacking that facilitates exciton-polaron annihilation.
- Deuteration Effect:** Replacing Hydrogen with Deuterium (Deuterated ADN) offers the highest stability jump. The C-D bond is stronger (lower zero-point energy), reducing the probability of bond dissociation in the excited state (Kinetic Isotope Effect) [3].

Experimental Protocols

To validate these stability claims in your own lab, follow these standardized protocols.

Protocol: Device Fabrication for Stability Testing

Objective: Create reproducible devices where the only variable is the anthracene derivative.

- Substrate Prep: Clean ITO glass (15 /sq) via ultrasonication in acetone, methanol, and IPA (15 min each). UV-Ozone treat for 15 min.
- Vacuum Deposition: Transfer to chamber (Torr).
- Layer Stack (Standard Blue):
 - HIL: HAT-CN (10 nm)
 - HTL: NPB (40 nm)
 - EML (Variable): Anthracene Host doped with 5% Blue Dopant (e.g., BD-1) (20 nm).
 - ETL: Alq3 or TPBi (30 nm)
 - EIL/Cathode: LiF (1 nm) / Al (100 nm)
- Encapsulation: Encapsulate immediately in glovebox using UV-curable epoxy and glass lids with desiccant.

Protocol: Accelerated Lifetime Measurement

Objective: Determine

(Time to 50% initial luminance).[6]

- Setup: Connect encapsulated devices to a multi-channel current source (e.g., Keithley 2400 or Ossila OLED Lifetime System).
- Driving Condition: Apply Constant Current Density (J).
 - Recommendation: Do not drive at constant voltage, as resistance increases over time.
 - Target: Set current to achieve an initial luminance (

) of 1,000 cd/m² (standard for blue).

- Data Logging: Record Luminance (

) and Voltage (

) every 60 seconds.

- Analysis: Plot Normalized Luminance (

) vs. Time. Fit the decay curve to the Stretched Exponential Decay (SED) equation to extrapolate if testing time is limited:

Visualization: Lifetime Testing Workflow

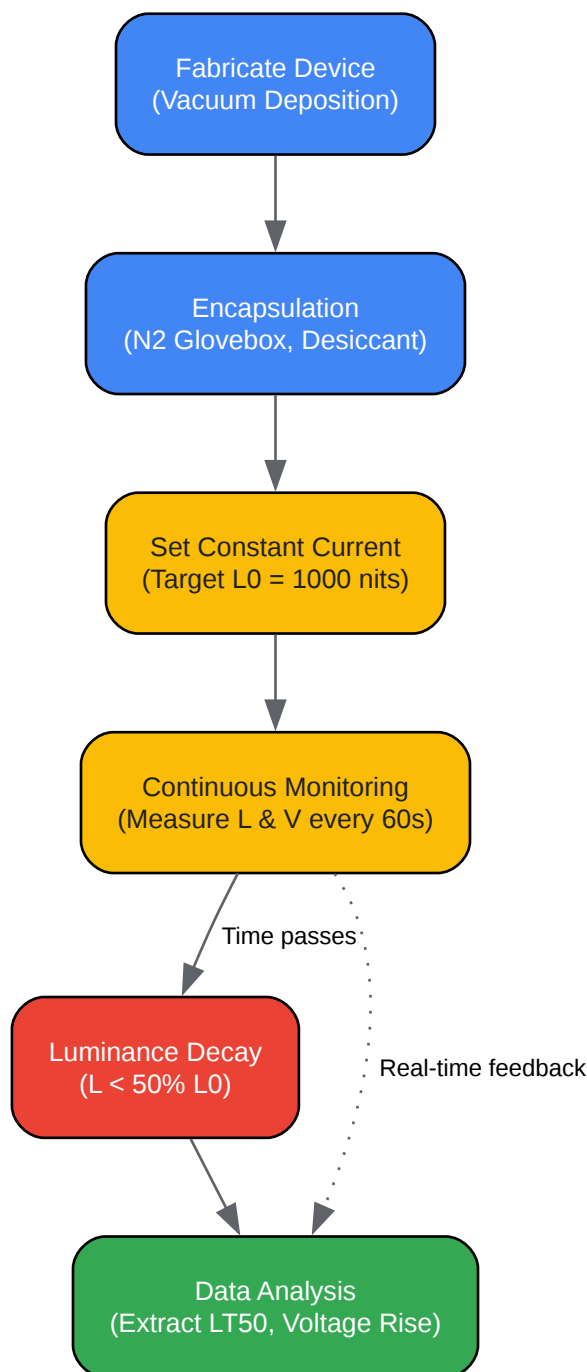

[Click to download full resolution via product page](#)

Figure 2: Workflow for accelerated OLED lifetime testing.

References

- Study of efficient and stable organic light-emitting diodes with 2-methyl-9,10-di(2-naphthyl)anthracene (MADN). Applied Physics Letters. [Link](#)

- Color Pure and Stable Blue Light Emitting Material Containing Anthracene and Fluorene. [Academia.edu.Link](#)
- Lifetime Enhancement and Degradation Study of Blue OLEDs Using Deuterated Materials. [ResearchGate.Link](#)
- Anthracene derivatives for stable blue-emitting organic electroluminescence devices. [ResearchGate.Link](#)

Need Custom Synthesis?

BenchChem offers custom synthesis for rare earth carbides and specific isotopic labeling.

Email: info@benchchem.com or [Request Quote Online](#).

Sources

- [1. mdpi.com \[mdpi.com\]](#)
- [2. researchgate.net \[researchgate.net\]](#)
- [3. mdpi.com \[mdpi.com\]](#)
- [4. researchgate.net \[researchgate.net\]](#)
- [5. mdpi.com \[mdpi.com\]](#)
- [6. How to Measure OLED Device Lifetime Under Continuous Usage \[eureka.patsnap.com\]](#)
- To cite this document: BenchChem. [Comparative analysis of the stability of different anthracene-based emitters]. BenchChem, [2026]. [Online PDF]. Available at: [\[https://www.benchchem.com/product/b8307509/docs#comparative-analysis-of-the-stability-of-different-anthracene-based-emitters\]](https://www.benchchem.com/product/b8307509/docs#comparative-analysis-of-the-stability-of-different-anthracene-based-emitters)

Disclaimer & Data Validity:

The information provided in this document is for Research Use Only (RUO) and is strictly not intended for diagnostic or therapeutic procedures. While BenchChem strives to provide accurate protocols, we make no warranties, express or implied, regarding the fitness of this product for every specific experimental setup.

Technical Support: The protocols provided are for reference purposes. Unsure if this reagent suits your experiment?

Need Industrial/Bulk Grade? [Request Custom Synthesis Quote](#)

BenchChem

Our mission is to be the trusted global source of essential and advanced chemicals, empowering scientists and researchers to drive progress in science and industry.

Contact

Address: 3281 E Guasti Rd
Ontario, CA 91761, United States
Phone: (601) 213-4426
Email: info@benchchem.com

[Contact our Ph.D. Support Team for a compatibility check](#)