

# Low efficacy of potassium phosphite tablet formulations in root zones.

**Author:** BenchChem Technical Support Team. **Date:** May 2026

## Compound of Interest

Compound Name: *Dipotassium phosphite*

CAS No.: 13492-26-7

Cat. No.: B083143

[Get Quote](#)

## Technical Support Center: Potassium Phosphite Formulations

This technical support center provides troubleshooting guidance and frequently asked questions (FAQs) for researchers, scientists, and drug development professionals working with potassium phosphite tablet formulations in root zones.

### Troubleshooting Guides & FAQs

This section addresses common issues encountered during experiments with potassium phosphite tablets.

#### Issue 1: Lack of Efficacy or Poor Plant Response

Q1: We are not observing the expected plant health benefits (e.g., disease suppression, enhanced growth) after applying potassium phosphite tablets to the root zone. What are the possible reasons?

A1: Several factors can contribute to the low efficacy of potassium phosphite tablets in the root zone:

- **Slow Release and Formulation:** Tablet formulations are designed for slow release. However, research indicates that this slow release may not provide a sufficient concentration of the active ingredient, phosphite, to be effective.[1][2] In contrast, liquid and granular formulations have demonstrated better performance in suppressing disease when applied to the root zone.[1][2]
- **Slow Conversion to Phosphate:** Phosphite ( $\text{PO}_3^{3-}$ ) is not readily metabolized by plants as a primary phosphorus source.[3][4][5] It must be converted to phosphate ( $\text{PO}_4^{3-}$ ) by soil microorganisms.[3][6] This is a slow process, with an estimated half-life of 3 to 4 months.[4] Consequently, the nutritional benefits are not immediate.
- **Incorrect Mode of Action Expectation:** Potassium phosphite's primary role is not as a direct fertilizer but as a biostimulant that activates the plant's natural defense mechanisms.[1][7][8] If you are expecting a rapid fertilizer effect, you will likely be disappointed. The benefits are more related to increased resistance to pathogens and environmental stress.[8]

Q2: Our plants are showing signs of phosphorus deficiency (e.g., stunted growth, purplish discoloration) after the application of potassium phosphite tablets. Why is this happening?

A2: This is a known issue, particularly in soils with low phosphate levels. Here's why:

- **Competition for Uptake:** Phosphite and phosphate ions are taken up by the plant through the same transporters.[9] In phosphate-deficient soil, the more mobile phosphite can outcompete the available phosphate for uptake, leading to or exacerbating phosphorus deficiency.[9]
- **Suppression of Phosphate Starvation Response:** Phosphite can "trick" the plant into thinking it has sufficient phosphate, which suppresses the plant's natural responses to phosphate starvation.[10] This interference with the plant's metabolic pathways can lead to reduced growth and symptoms of phosphorus deficiency.[10][11]

Q3: We are using a slow-release tablet formulation, but the results are inconsistent. What could be the cause?

A3: The inconsistency in results from slow-release tablets can be attributed to several factors:

- **Environmental and Soil Conditions:** The rate of release from the tablet and the subsequent conversion of phosphite to phosphate are highly dependent on soil moisture, temperature, and microbial activity.[2] Variations in these conditions can lead to unpredictable results.
- **Low Active Ingredient Release:** The tablet formulation may not be releasing a sufficient dose of the active ingredient to be effective, especially during critical periods of plant susceptibility to infection.[1]

## Issue 2: Experimental Design and Data Interpretation

Q4: How can we accurately assess the efficacy of our potassium phosphite tablet formulation in our experiments?

A4: A well-designed experiment is crucial. Consider the following:

- **Appropriate Controls:** Include untreated controls and positive controls (e.g., a proven effective liquid phosphite formulation and a standard phosphate fertilizer).
- **Phosphate Levels:** Ensure your growing medium has sufficient levels of phosphate to avoid inducing phosphorus deficiency.
- **Multiple Time Points:** Evaluate plant responses at various time points post-application to account for the slow-release nature of the tablets and the time required for the plant to mount a defense response.
- **Relevant Metrics:** Measure parameters that reflect both the expected biostimulant effect (e.g., disease incidence/severity, expression of defense-related genes) and any potential negative effects (e.g., root and shoot biomass, signs of phytotoxicity).

Q5: What is the best method to quantify the amount of phosphite in our soil and plant tissue samples?

A5: High-Performance Ion Chromatography (HPIC) is a reliable and widely used method for the determination of phosphite and phosphate concentrations in plant and soil samples.[12] There are also fluorescent enzyme assays available that can be cost-effective alternatives.[12]

## Data Presentation

Table 1: Comparison of Potassium Phosphite Formulations on Foliar Phytophthora Infection in Rhododendron

Formulation	Application Method	Lesion Area Suppression (vs. Control)	Duration of Suppression	Reference
Tablet (Fertilizer)	Placed in root zone	Not effective at any time point	N/A	[1]
Liquid (Fungicide)	Soil Drench	Significant reduction	8 to 12 weeks	[1][2]
Granular (Fertilizer)	Broadcast on soil surface	Significant reduction	6 to 8 weeks	[1][2]

## Experimental Protocols

### 1. Protocol for Evaluating the Efficacy of Root-Applied Potassium Phosphite Formulations

This protocol outlines a general procedure for assessing the efficacy of potassium phosphite tablets against a model pathogen.

#### a. Plant Material and Growth Conditions:

- Select a plant species susceptible to a known root or foliar pathogen (e.g., Rhododendron for Phytophthora).
- Grow plants in a controlled environment (greenhouse) in pots with a standardized, phosphate-sufficient growing medium.
- Maintain consistent watering, light, and temperature conditions.

#### b. Treatments:

- Control Group: No treatment.
- Placebo Group: A tablet without the active ingredient.
- Potassium Phosphite Tablet Group: Apply tablets to the root zone according to the manufacturer's instructions.
- Positive Control (Liquid Formulation): Apply a liquid potassium phosphite formulation as a soil drench at a recommended rate.

- Positive Control (Phosphate Fertilizer): Apply a standard phosphate fertilizer to a separate group to assess nutritional effects.
  - Replicate each treatment group sufficiently (e.g., 5-10 plants per group).
- c. Pathogen Inoculation:
- At a predetermined time after treatment application (e.g., 1, 3, 6, and 8 weeks), inoculate a subset of plants from each group with the pathogen.
  - For foliar pathogens, this can be done by applying a spore suspension to the leaves. For root pathogens, the inoculum can be incorporated into the soil.
- d. Data Collection:
- Disease Assessment: At various time points post-inoculation, assess disease severity (e.g., lesion size, percentage of infected tissue).
  - Plant Growth Parameters: Measure plant height, shoot and root biomass (dry weight).
  - Phytotoxicity: Visually inspect plants for any signs of damage, such as leaf necrosis or stunting.
  - (Optional) Phosphite/Phosphate Analysis: Collect soil and plant tissue samples to quantify phosphite and phosphate concentrations using HPIC.

## 2. Protocol for Quantification of Phosphite in Soil and Plant Tissue by HPIC (High-Performance Ion Chromatography)

This is a summarized protocol based on established methods.[\[12\]](#)

### a. Sample Preparation:

- Plant Tissue: Dry the plant material and grind it into a fine powder.
- Soil: Air-dry the soil and sieve it to remove large debris.
- Extraction: Extract phosphite and phosphate from the prepared samples using a suitable extraction solution (e.g., deionized water or a weak acid). Shake the mixture for a specified period and then centrifuge or filter to obtain a clear extract.

### b. HPIC Analysis:

- Instrumentation: Use an ion chromatograph equipped with a suitable anion-exchange column and a conductivity detector.

- Mobile Phase: An appropriate eluent, such as a sodium hydroxide or sodium carbonate/bicarbonate solution, is used to separate the ions.
- Calibration: Prepare a series of standard solutions with known concentrations of phosphite and phosphate to create a calibration curve.
- Injection and Detection: Inject the sample extracts and standards into the HPIC system. The separated phosphite and phosphate ions are detected by the conductivity detector.
- Quantification: Determine the concentration of phosphite and phosphate in the samples by comparing their peak areas to the calibration curve.

## Mandatory Visualizations

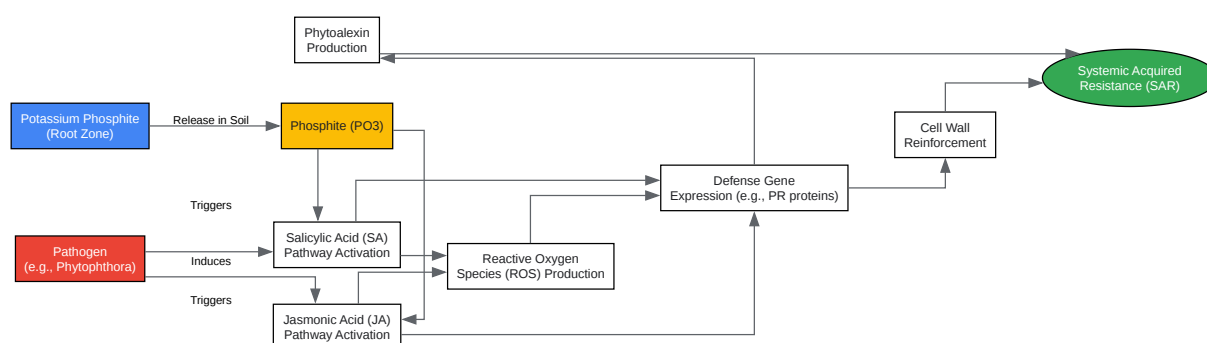

[Click to download full resolution via product page](#)

Caption: Phosphite-induced plant defense signaling pathway.

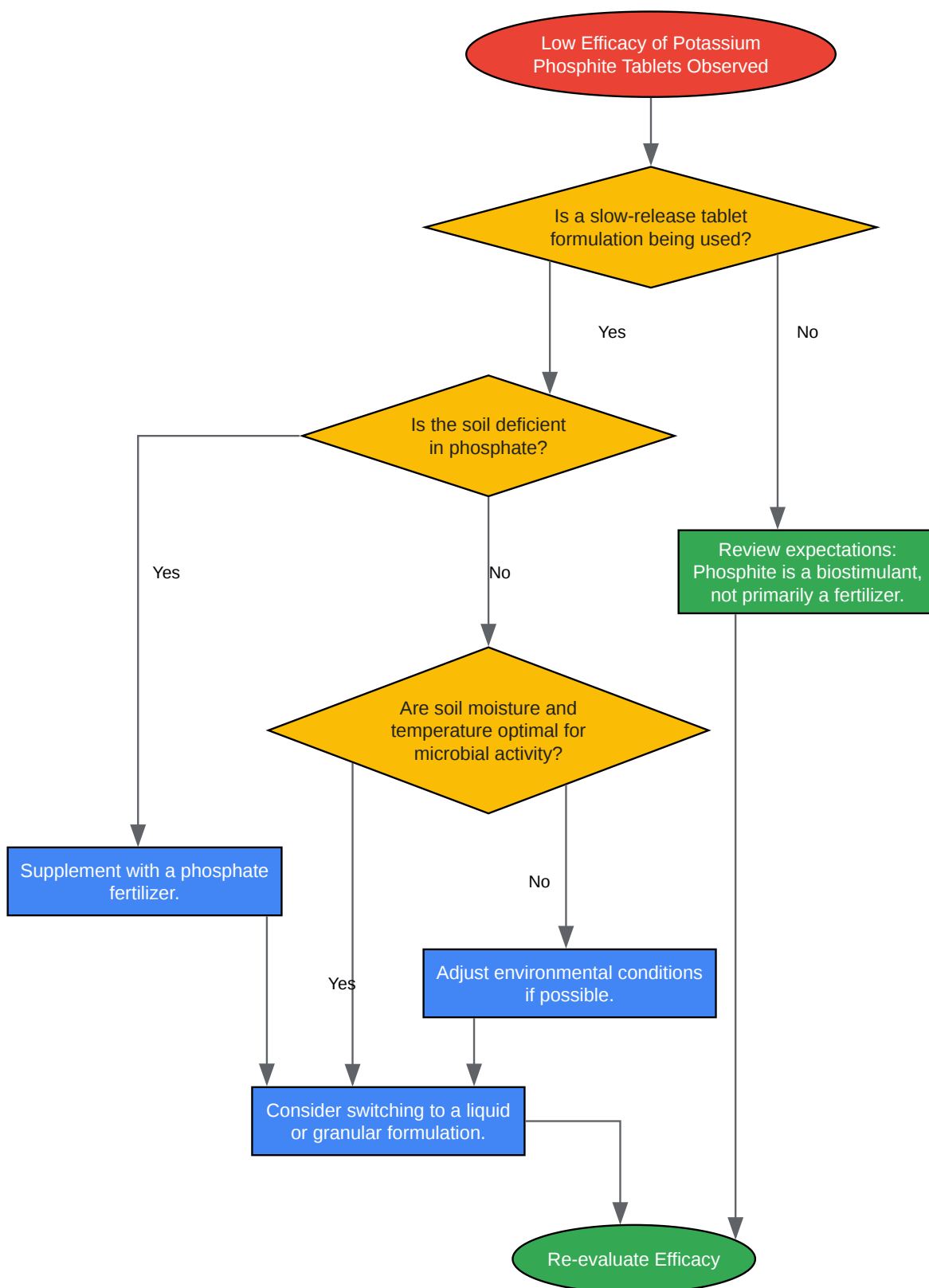

[Click to download full resolution via product page](#)

Caption: Troubleshooting workflow for low efficacy of potassium phosphite tablets.

### Need Custom Synthesis?

BenchChem offers custom synthesis for rare earth carbides and specific isotopic labeling.

Email: [info@benchchem.com](mailto:info@benchchem.com) or [Request Quote Online](#).

## References

- [1. assets.greenbook.net](https://assets.greenbook.net) [[assets.greenbook.net](https://assets.greenbook.net)]
- [2. eu.vlsci.com](https://eu.vlsci.com) [[eu.vlsci.com](https://eu.vlsci.com)]
- [3. Phosphite treatment can improve root biomass and nutrition use efficiency in wheat - PMC](https://pubmed.ncbi.nlm.nih.gov/31111111/) [[pmc.ncbi.nlm.nih.gov](https://pubmed.ncbi.nlm.nih.gov/31111111/)]
- [4. The functional mechanisms of phosphite and its applications in crop plants - PMC](https://pubmed.ncbi.nlm.nih.gov/31111112/) [[pmc.ncbi.nlm.nih.gov](https://pubmed.ncbi.nlm.nih.gov/31111112/)]
- [5. Quantification of root phosphite concentrations for evaluating the potential of foliar phosphonate sprays for the manag...](https://www.ouci.dntb.gov.ua/) [[ouci.dntb.gov.ua](https://www.ouci.dntb.gov.ua/)]
- [6. apsjournals.apsnet.org](https://apsjournals.apsnet.org/) [[apsjournals.apsnet.org](https://apsjournals.apsnet.org/)]
- [7. frontiersin.org](https://frontiersin.org/) [[frontiersin.org](https://frontiersin.org/)]
- [8. researchgate.net](https://www.researchgate.net/) [[researchgate.net](https://www.researchgate.net/)]
- [9. The Efficacy of Various Preventive Soil-Applied Potassium Phosphite Products Against Foliar Phytophthora Infections on Rhododendron over Time | Arboriculture & Urban Forestry](https://auf.isa-arbor.com/) [[auf.isa-arbor.com](https://auf.isa-arbor.com/)]
- [10. assets.greenbook.net](https://assets.greenbook.net) [[assets.greenbook.net](https://assets.greenbook.net)]
- [11. d-nb.info](https://d-nb.info/) [[d-nb.info](https://d-nb.info/)]
- [12. grownnextgen.org](https://grownnextgen.org/) [[grownnextgen.org](https://grownnextgen.org/)]
- To cite this document: BenchChem. [Low efficacy of potassium phosphite tablet formulations in root zones.]. BenchChem, [2026]. [Online PDF]. Available at: [<https://www.benchchem.com/product/b083143/docs#low-efficacy-of-potassium-phosphite-tablet-formulations-in-root-zones>]

---

### Disclaimer & Data Validity:

The information provided in this document is for Research Use Only (RUO) and is strictly not intended for diagnostic or therapeutic procedures. While BenchChem strives to provide accurate protocols, we make no warranties, express or implied, regarding the fitness of this product for every specific experimental setup.

**Technical Support:** The protocols provided are for reference purposes. Unsure if this reagent suits your experiment?

**Need Industrial/Bulk Grade?** [Request Custom Synthesis Quote](#)

## BenchChem

Our mission is to be the trusted global source of essential and advanced chemicals, empowering scientists and researchers to drive progress in science and industry.

### Contact

Address: 3281 E Guasti Rd  
Ontario, CA 91761, United States  
Phone: (601) 213-4426  
Email: [info@benchchem.com](mailto:info@benchchem.com)

[Contact our Ph.D. Support Team for a compatibility check](#)