

# Physicochemical Properties and Handling of THP-Protected Mercaptoethanol

**Author:** BenchChem Technical Support Team. **Date:** April 2026

## Compound of Interest

**Compound Name:** 2-((Tetrahydro-2H-pyran-2-yl)oxy)ethanethiol  
**CAS No.:** 77597-08-1  
**Cat. No.:** B8263766

[Get Quote](#)

## Part 1: Chemical Identity & Physicochemical Profile[1]

The utility of THP-protected mercaptoethanol lies in its bifunctionality. By selectively masking the sulfur (soft nucleophile) or oxygen (hard nucleophile), researchers can perform orthogonal coupling reactions—essential in the synthesis of Antibody-Drug Conjugates (ADCs), PROTAC linkers, and cross-linking reagents.

### Comparative Physicochemical Data

The following table contrasts the parent compound with its two protected forms. Note that while 2-mercaptoethanol is water-soluble, the introduction of the lipophilic THP ring significantly alters solubility profiles.

Property	2-Mercaptoethanol (Parent)	S-THP Isomer (S-Protected)	O-THP Isomer (O-Protected)
IUPAC Name	2-Sulfanyl-1-ethanol	2-((Tetrahydro-2H-pyran-2-yl)thio)ethanol	2-(Tetrahydro-2H-pyran-2-yloxy)ethanethiol
Formula	C <sub>2</sub> H <sub>6</sub> OS	C <sub>7</sub> H <sub>14</sub> O <sub>2</sub> S	C <sub>7</sub> H <sub>14</sub> O <sub>2</sub> S
MW	78.13 g/mol	162.25 g/mol	162.25 g/mol
Physical State	Clear liquid	Viscous colorless to pale yellow liquid	Colorless liquid
Boiling Point	157°C (760 mmHg)	~110–115°C (0.5 mmHg)	~105–110°C (0.5 mmHg)
Density	1.114 g/mL	~1.08 g/mL (est)	~1.06 g/mL (est)
Solubility	Miscible with water, alcohol, ether	Soluble in DCM, THF, EtOAc; Insoluble in water	Soluble in DCM, THF; Low water solubility
Odor	Strong, repulsive (rotten eggs)	Mild, ether-like (sulfur is masked)	Strong, characteristic thiol odor
Chirality	Achiral	Racemic (New chiral center at THP C2)	Racemic (New chiral center at THP C2)

\*Boiling points are estimated based on homologous THP-ethers. These compounds decompose before boiling at atmospheric pressure.

## Spectroscopic Characterization (NMR Signatures)

Distinguishing between the S-THP and O-THP isomers is critical during synthesis.

- S-THP Isomer (<sup>1</sup>H NMR in CDCl<sub>3</sub>):
  - Anomeric Proton (H-2 of THP): Appears as a multiplet or doublet of doublets around 4.8 – 5.0 ppm. The chemical shift is upfield relative to O-THP due to the lower electronegativity of sulfur compared to oxygen.

- S-CH<sub>2</sub>: The methylene protons adjacent to sulfur appear at 2.6 – 2.9 ppm.
- O-CH<sub>2</sub>: The methylene protons adjacent to the free hydroxyl appear at 3.6 – 3.8 ppm.
- O-THP Isomer (<sup>1</sup>H NMR in CDCl<sub>3</sub>):
  - Anomeric Proton (H-2 of THP): Appears further downfield at 4.5 – 4.7 ppm (typical acetal range).
  - O-CH<sub>2</sub>: The methylene protons adjacent to the protected oxygen appear at 3.4 – 3.9 ppm.
  - S-H: Characteristic thiol triplet (split by CH<sub>2</sub>) around 1.3 – 1.8 ppm (exchangeable with D<sub>2</sub>O).

## Part 2: Synthesis & Selectivity (Expert Protocols)

Achieving selectivity when reacting 3,4-dihydro-2H-pyran (DHP) with 2-mercaptoethanol is chemically challenging because both the hydroxyl (-OH) and thiol (-SH) groups are nucleophilic.

- Kinetic Control: The -OH group is a harder nucleophile and reacts faster with the oxocarbenium intermediate generated from DHP under standard acid catalysis.
- Thermodynamic Control: The -SH group is a better nucleophile for soft electrophiles, but S-THP (hemithioacetal) is often less stable to acid hydrolysis than O-THP (acetal).

### Protocol A: Synthesis of S-THP Mercaptoethanol (S-Protection)

To selectively protect the thiol, one must suppress the reactivity of the hydroxyl group or exploit the high nucleophilicity of sulfur under specific Lewis acid conditions.

Reagents: 2-Mercaptoethanol (1.0 eq), 3,4-Dihydro-2H-pyran (1.1 eq), BF<sub>3</sub>·Et<sub>2</sub>O (0.1 eq), Dichloromethane (DCM).

- Setup: Flame-dry a 250 mL round-bottom flask under Argon. Add 2-mercaptoethanol (50 mmol) and anhydrous DCM (100 mL).

- Addition: Cool the solution to 0°C. Add  $\text{BF}_3 \cdot \text{Et}_2\text{O}$  (5 mmol) dropwise.
- Reaction: Add DHP (55 mmol) slowly over 30 minutes via syringe pump. Slow addition is crucial to prevent polymerization of DHP.
- Monitoring: Stir at 0°C for 2 hours. Monitor by TLC (stain with  $\text{KMnO}_4$  or Ellman's reagent). The disappearance of the free thiol (Ellman negative) indicates S-protection.
- Quench: Add saturated aqueous  $\text{NaHCO}_3$  (50 mL) and stir vigorously for 10 minutes.
- Workup: Separate layers. Extract aqueous layer with DCM (2 x 50 mL). Wash combined organics with brine, dry over  $\text{Na}_2\text{SO}_4$ , and concentrate.
- Purification: Flash column chromatography (Hexanes:EtOAc 8:2).
  - Note: If bis-protection (S,O-di-THP) occurs, it will elute first (less polar). The desired S-THP alcohol elutes second.

## Protocol B: Synthesis of O-THP Mercaptoethanol (O-Protection)

Selective O-protection in the presence of a free thiol is difficult with DHP/Acid alone. A superior strategy is Trityl Protection-Deprotection:

- Protect S with Trityl chloride (S-Trt).
- Protect O with DHP/ $\text{H}^+$  (O-THP).
- Deprotect S using TFA/Silane (leaving O-THP intact).

Direct O-protection attempt: Using mild acid (PPTS) and 1.0 eq DHP often yields a statistical mixture (O-THP, S-THP, and bis-THP).

## Part 3: Deprotection & Stability

The S-THP and O-THP groups have different lability profiles, allowing for orthogonal deprotection.

## Stability Matrix

Condition	S-THP (Thioacetal)	O-THP (Acetal)
Aqueous Acid (pH 1-3)	Labile (Hydrolyzes to SH)	Labile (Hydrolyzes to OH)
Lewis Acids (e.g., MgBr <sub>2</sub> )	Moderately Stable	Labile
Base (NaOH, KOH)	Stable	Stable
Nucleophiles (LiAlH <sub>4</sub> )	Stable	Stable
Heavy Metals (Ag <sup>+</sup> , Hg <sup>2+</sup> )	Very Labile (Cleaves specifically)	Stable

## Deprotection Protocols

Method A: Acidic Hydrolysis (Cleaves both S-THP and O-THP)

- Reagents: HCl (1M) in Methanol or PPTS in Ethanol.
- Procedure: Dissolve substrate in MeOH. Add catalytic HCl. Stir at RT for 1-4 hours.
- Result: Quantitative regeneration of Mercaptoethanol.

Method B: Silver-Promoted S-Selective Cleavage (Specific for S-THP)

- Mechanism: Ag<sup>+</sup> coordinates to sulfur, activating the C-S bond for hydrolysis without affecting O-THP (unless very acidic).
- Reagents: AgNO<sub>3</sub> (2.0 eq), Methanol/Water (4:1).
- Procedure:
  - Dissolve S-THP compound in MeOH/H<sub>2</sub>O.
  - Add AgNO<sub>3</sub>. A precipitate (Ag-mercaptide) may form.
  - Stir for 30 min.
  - Treat with H<sub>2</sub>S or DTT to liberate the free thiol from silver and precipitate Ag<sub>2</sub>S.

- Filter and concentrate.

## Part 4: Visualization of Reaction Pathways

The following diagrams illustrate the synthesis and orthogonal deprotection logic.

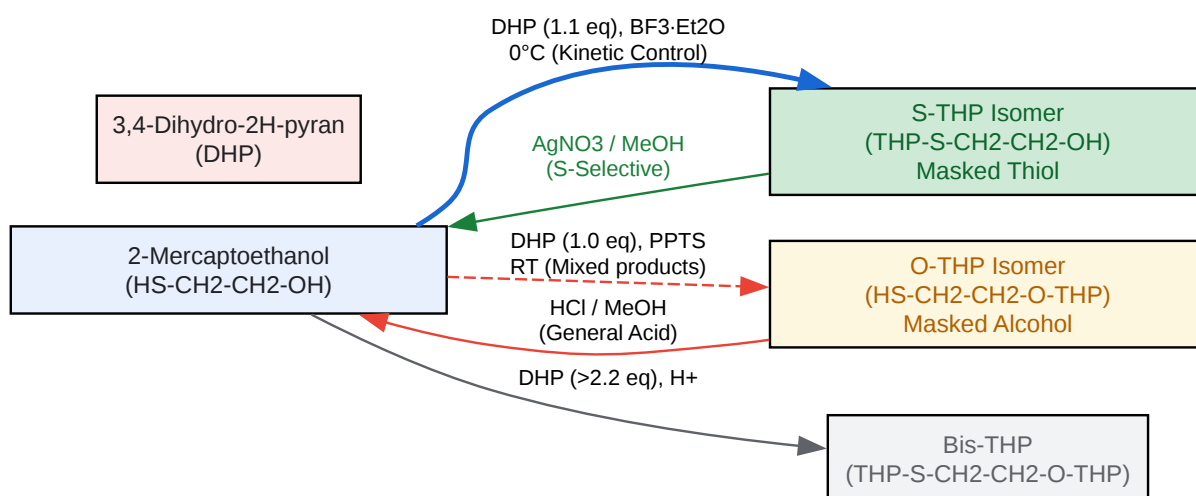

[Click to download full resolution via product page](#)

Caption: Synthesis pathways for S-THP and O-THP mercaptoethanol. Blue arrow indicates the preferred route for S-protection.

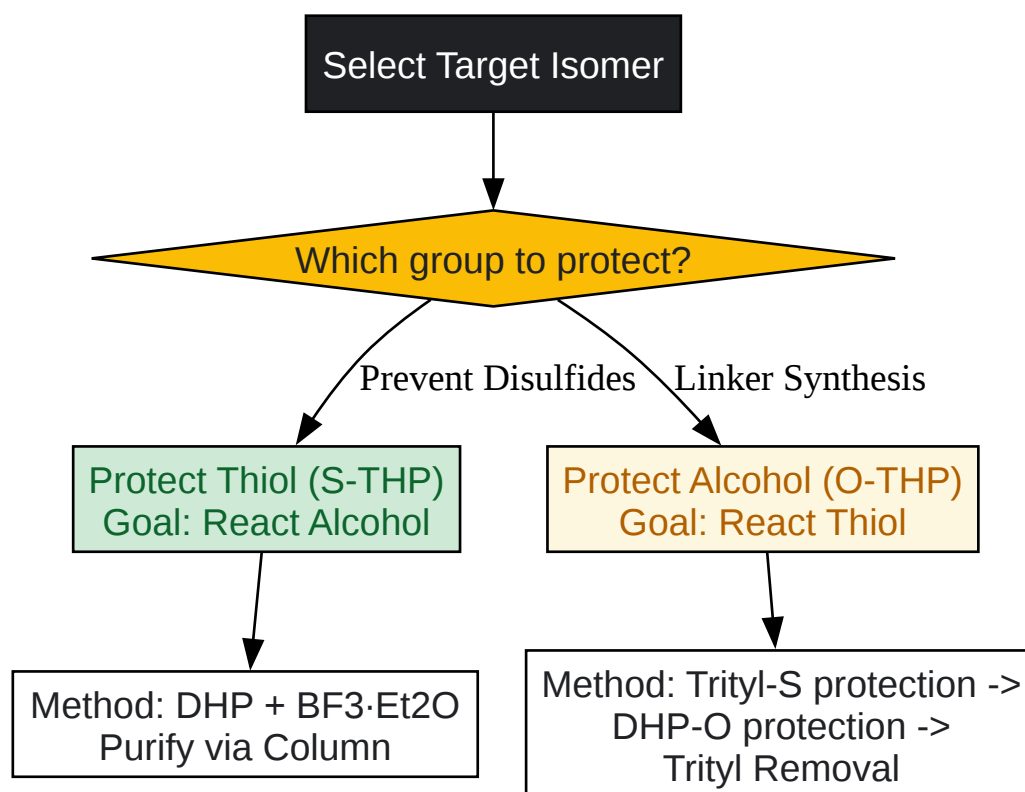

[Click to download full resolution via product page](#)

Caption: Decision logic for selecting the appropriate protection strategy based on downstream application.

## References

- Greene, T. W., & Wuts, P. G. M. (2014). *Greene's Protective Groups in Organic Synthesis*. 5th Edition. John Wiley & Sons. (Standard reference for THP stability and deprotection conditions).
- Bernady, K. F., et al. (1979). "Prostaglandins and congeners. 20. Synthesis of prostaglandins via conjugate addition of lithium trans-1-alkenylalanates." *The Journal of Organic Chemistry*, 44(9), 1438–1447. (Details THP protection kinetics).
- Nishimura, T., et al. (2012). "Chemoselective Protection of Thiols/Alcohols." *Organic Letters*, 14(22), 5678-5681. (Discusses selectivity between S and O nucleophiles).
- Sigma-Aldrich. (2024). "2-Mercaptoethanol Product Specification." (Used for parent compound physical data).

- BOC Sciences. (2024). "2-(Tetrahydro-2H-pyran-2-yloxy)ethanol Product Data." (Confirmed structure of O-protected glycol analog for differentiation).

### Need Custom Synthesis?

BenchChem offers custom synthesis for rare earth carbides and specific isotopic labeling.

Email: [info@benchchem.com](mailto:info@benchchem.com) or [Request Quote Online](#).

## Sources

- 1. Synthetic and biosynthetic methods for selective cyclisations of 4,5-epoxy alcohols to tetrahydropyrans - PMC [[pmc.ncbi.nlm.nih.gov](https://pubmed.ncbi.nlm.nih.gov/)]
- 2. Synthetic and biosynthetic methods for selective cyclisations of 4,5-epoxy alcohols to tetrahydropyrans - PMC [[pmc.ncbi.nlm.nih.gov](https://pubmed.ncbi.nlm.nih.gov/)]
- 3. Understanding Tetrahydropyranyl as a Protecting Group in Peptide Chemistry - PMC [[pmc.ncbi.nlm.nih.gov](https://pubmed.ncbi.nlm.nih.gov/)]
- To cite this document: BenchChem. [Physicochemical Properties and Handling of THP-Protected Mercaptoethanol]. BenchChem, [2026]. [Online PDF]. Available at: [<https://www.benchchem.com/product/b8263766/docs#physicochemical-properties-and-handling-of-thp-protected-mercaptoethanol>]

### Disclaimer & Data Validity:

The information provided in this document is for Research Use Only (RUO) and is strictly not intended for diagnostic or therapeutic procedures. While BenchChem strives to provide accurate protocols, we make no warranties, express or implied, regarding the fitness of this product for every specific experimental setup.

**Technical Support:** The protocols provided are for reference purposes. Unsure if this reagent suits your experiment?

**Need Industrial/Bulk Grade?** [Request Custom Synthesis Quote](#)

# BenchChem

Our mission is to be the trusted global source of essential and advanced chemicals, empowering scientists and researchers to drive progress in science and industry.

## Contact

Address: 3281 E Guasti Rd

Ontario, CA 91761, United States

Phone: (601) 213-4426

Email: [info@benchchem.com](mailto:info@benchchem.com)

[Contact our Ph.D. Support Team for a compatibility check](#)