

Medicinal Chemistry Building Blocks: Indazole Derivatives

Author: BenchChem Technical Support Team. **Date:** April 2026

Compound of Interest

Compound Name: *6-Bromo-4-chloro-1-methyl-1H-indazole*

Cat. No.: *B8263190*

[Get Quote](#)

Technical Guide & Whitepaper

Executive Summary

The indazole (benzo[c]pyrazole) scaffold represents a "privileged structure" in modern medicinal chemistry.^{[1][2]} Structurally distinct from its isomer benzimidazole and its carba-analog indole, indazole offers a unique electronic profile that bridges the gap between lipophilic aromatic cores and polar hydrogen-bond networks.

This guide provides a technical deep-dive into the utility of indazole building blocks. We analyze the scaffold's bioisosteric properties, resolve the persistent challenge of N1- vs. N2-regioselectivity, and detail the synthetic pathways that have led to FDA-approved therapeutics like Axitinib, Pazopanib, and Niraparib.

Structural Properties & Bioisosterism^{[2][3][4][5]} Electronic Profile and Tautomerism

Indazole exists in two tautomeric forms: 1H-indazole and 2H-indazole.

- Thermodynamics: The 1H-tautomer is aromatic (10 π -electrons) and thermodynamically favored by approximately 2–4 kcal/mol over the 2H-form, which possesses an ortho-quinoid character.
- Acidity/Basicity:
 - pKa (NH deprotonation): ~13.8 (comparable to imidazole, more acidic than indole).
 - pKa (N2 protonation): ~1.2 (weak base).

Bioisosteric Utility

The indazole core is frequently employed as a bioisostere for:

- Indole: Mimics the size and shape but adds a hydrogen bond acceptor (N2), improving water solubility and altering metabolic susceptibility (e.g., reducing C3-oxidation).
- Phenol: The NH of indazole mimics the phenolic OH as a hydrogen bond donor, while the aromatic system maintains lipophilicity. Crucially, indazole avoids rapid Phase II conjugation (glucuronidation) often seen with phenols.
- Purine (Adenine): In kinase inhibitors, the indazole motif perfectly mimics the adenine hinge-binding region, offering a donor-acceptor (NH-N) pair.

Synthetic Strategies: Constructing the Core

Efficient access to functionalized indazoles relies on three primary retrosynthetic disconnections.

Core Construction Pathways

The choice of pathway depends heavily on the desired substitution pattern at C3 and the benzene ring.

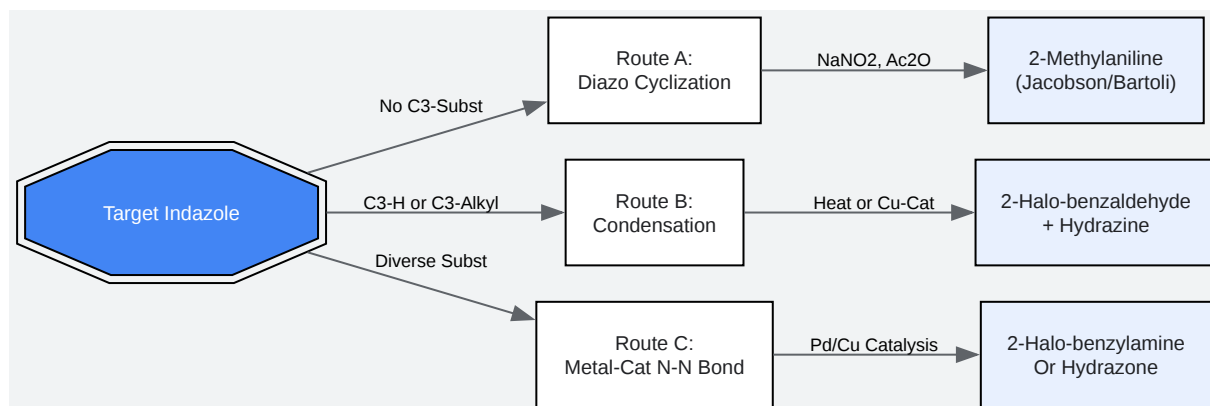

[Click to download full resolution via product page](#)

Figure 1: Primary retrosynthetic disconnections for indazole core synthesis.

The Regioselectivity Challenge (N1 vs. N2)

Functionalizing the nitrogen atoms is the most critical step in indazole building block utilization. The selectivity is governed by the interplay of sterics, electronics, and thermodynamics.[3]

Parameter	N1-Alkylation	N2-Alkylation
Thermodynamics	Favored (Aromatic system retained)	Disfavored (Quinoid character)
Kinetics	Slower (Steric hindrance from C7-H)	Faster (Less hindered lone pair)
Conditions	Strong base (NaH, KOtBu), polar solvent, high temp.	Weak base, non-polar solvent, alkylating agents with lone pairs (e.g., Meerwein salts).
Electronic Effect	Electron-donating groups on ring favor N1.	Electron-withdrawing groups (esp. at C4/C7) can shift preference to N2.

Expert Insight: To achieve exclusive N1-alkylation, use thermodynamic control: allow the reaction to equilibrate at elevated temperatures using bases like Cs_2CO_3 in DMF or NaH in THF. For N2-alkylation, kinetic control is required; however, direct N2-alkylation is often low-yielding. A superior strategy for N2-derivatives is to use the Semmler-Wolff aromatization of oximes or specific copper-catalyzed coupling of hydrazines.

Medicinal Chemistry Applications

Kinase Inhibition (Hinge Binding)

Indazoles are premier ATP-competitive inhibitors. The 1H-indazole tautomer presents a "Donor-Acceptor" motif that binds to the kinase hinge region (typically the backbone carbonyl and amide NH of the hinge residues).

Mechanism:

- N1-H (Donor): Forms H-bond with the hinge backbone carbonyl (e.g., Glu, Leu).
- N2 (Acceptor): Forms H-bond with the hinge backbone NH.
- C3-Substituent: Vectors into the hydrophobic pocket or solvent front, determining selectivity.

Case Studies: Approved Drugs

Drug	Target	Indication	Indazole Role
Axitinib (Inlyta)	VEGFR 1/2/3	Renal Cell Carcinoma	N1-substituted: Mimics adenine; forms bidentate H-bonds with the hinge region of VEGFR2.
Pazopanib (Votrient)	VEGFR/PDGFR	Sarcoma / RCC	2H-indazole: A rare example where the 2H-tautomer (stabilized by methylation) serves as the core scaffold.
Niraparib (Zejula)	PARP 1/2	Ovarian Cancer	C3-substituted: The indazole carboxamide mimics the nicotinamide moiety of NAD+.
Entrectinib (Rozlytrek)	ROS1/TRK	NSCLC (ROS1+)	N1-substituted: Indazole acts as the hinge binder in the ATP pocket.

Experimental Protocol: Regioselective N1-Alkylation

This protocol is designed to maximize the thermodynamic N1-product over the kinetic N2-product.

Objective: Synthesis of 1-methyl-1H-indazole-3-carboxylic acid methyl ester.

Reagents:

- Indazole-3-carboxylic acid methyl ester (1.0 eq)
- Cesium Carbonate (Cs_2CO_3) (2.0 eq) - Promotes thermodynamic equilibration

- Methyl Iodide (MeI) (1.2 eq)
- DMF (Anhydrous)

Workflow:

- Dissolution: Dissolve indazole substrate in anhydrous DMF (0.2 M concentration).
- Base Addition: Add Cs_2CO_3 in one portion. Stir at Room Temperature (RT) for 15 min.
- Alkylation: Add MeI dropwise.
- Equilibration (Critical Step): Heat the reaction to 60°C for 4 hours.
 - Why? At RT, a mixture of N1 and N2 is formed. Heating allows the reversible N2-alkylated product to rearrange (via intermolecular transfer or de-alkylation/re-alkylation) to the more stable N1-isomer.
- Workup: Dilute with EtOAc, wash with LiCl (5% aq) to remove DMF, then brine. Dry over Na_2SO_4 .^[4]
- Purification: Flash chromatography (Hexane/EtOAc). N1 isomer elutes second (more polar) on silica due to the exposed N2 lone pair interacting with the stationary phase.

Logic Diagram: Regioselectivity Decision Tree

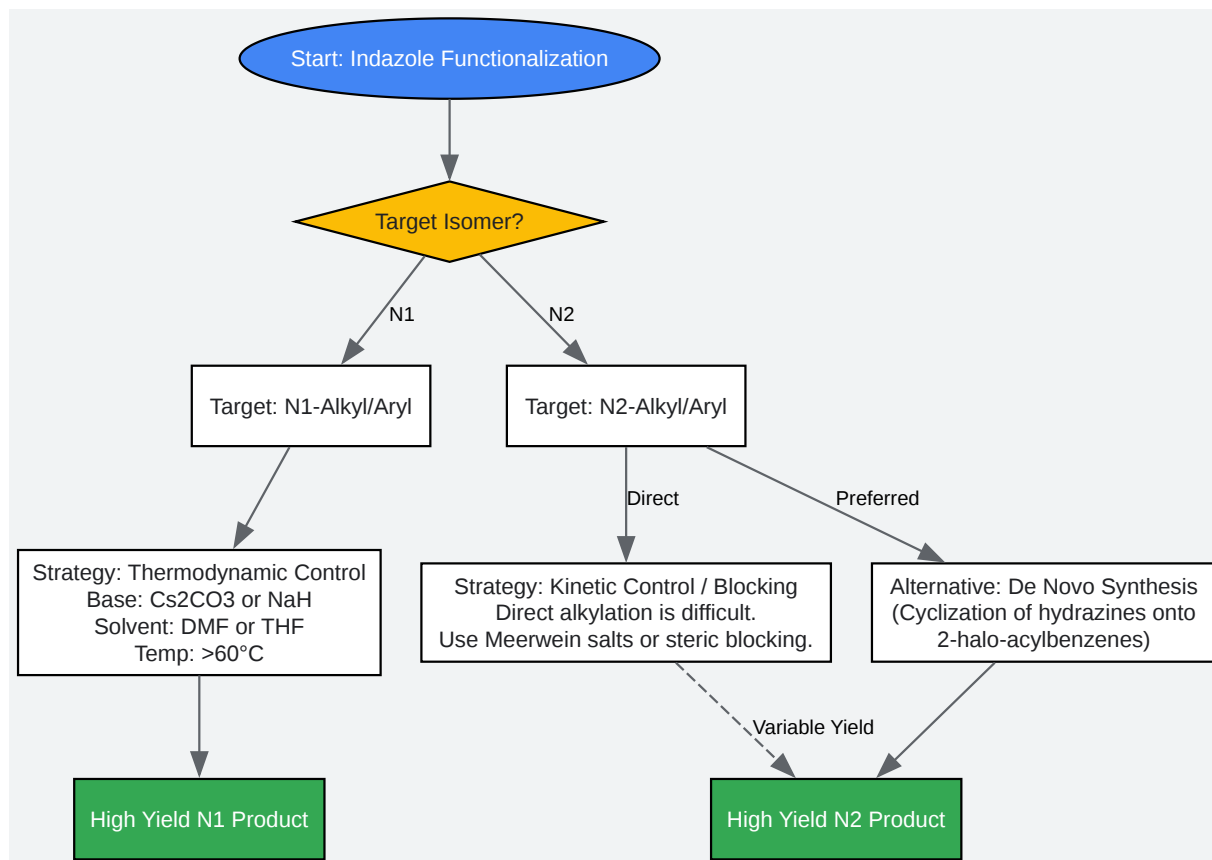

[Click to download full resolution via product page](#)

Figure 2: Decision matrix for achieving regioselective functionalization of the indazole ring.

Future Outlook

The indazole scaffold is evolving beyond simple inhibition.

- PROTACs: Indazole-based kinase inhibitors are increasingly used as "warheads" for Proteolysis Targeting Chimeras due to their high affinity and amenable solvent-front vectors (usually at C3 or C5) for linker attachment.
- FBDD (Fragment-Based Drug Discovery): Low molecular weight indazoles (e.g., 3-aminoindazole) are standard fragments in screening libraries due to their high ligand efficiency (LE).

References

- BenchChem. Discovery and synthesis of novel indazole derivatives. (2025). [3][5] [Link](#)
- Zhang, L., et al. Recent Advances in Indazole-Containing Derivatives: Synthesis and Biological Perspectives. *Molecules*, 23(11), 2783. (2018). [6] [Link](#)
- Meanwell, N. A. The Influence of Bioisosteres in Drug Design: Tactical Applications to Address Developability Problems. *J. Med. Chem.* (2011). [Link](#)
- FDA. Orange Book: Approved Drug Products with Therapeutic Equivalence Evaluations. (Axitinib, Pazopanib). [8] [Link](#)
- Hunt, K. W., et al. Regioselective N-alkylation of the 1H-indazole scaffold. [9] *Beilstein J. Org. Chem.*, 17, 1963–1971. (2021). [10][11] [Link](#)

Need Custom Synthesis?

BenchChem offers custom synthesis for rare earth carbides and specific isotopic labeling.

Email: info@benchchem.com or [Request Quote Online](#).

Sources

- 1. img01.pharmablock.com [img01.pharmablock.com]
- 2. pdf.benchchem.com [pdf.benchchem.com]
- 3. pdf.benchchem.com [pdf.benchchem.com]
- 4. pdf.benchchem.com [pdf.benchchem.com]
- 5. researchgate.net [researchgate.net]
- 6. mdpi.com [mdpi.com]
- 7. Indazole as a Phenol Bioisostere: Structure-Affinity Relationships of GluN2B-Selective NMDA Receptor Antagonists - PubMed [pubmed.ncbi.nlm.nih.gov]
- 8. Indazole – an emerging privileged scaffold: synthesis and its biological significance - PMC [pmc.ncbi.nlm.nih.gov]

- [9. Regioselective N-alkylation of the 1H-indazole scaffold; ring substituent and N-alkylating reagent effects on regioisomeric distribution - PMC \[pmc.ncbi.nlm.nih.gov\]](#)
- [10. researchgate.net \[researchgate.net\]](#)
- [11. Synthesis of indazoles from 2-formylphenylboronic acids - RSC Advances \(RSC Publishing\) DOI:10.1039/D1RA04056A \[pubs.rsc.org\]](#)
- To cite this document: BenchChem. [Medicinal Chemistry Building Blocks: Indazole Derivatives]. BenchChem, [2026]. [Online PDF]. Available at: [\[https://www.benchchem.com/product/b8263190/docs#medicinal-chemistry-building-blocks-indazole-derivatives\]](https://www.benchchem.com/product/b8263190/docs#medicinal-chemistry-building-blocks-indazole-derivatives)

Disclaimer & Data Validity:

The information provided in this document is for Research Use Only (RUO) and is strictly not intended for diagnostic or therapeutic procedures. While BenchChem strives to provide accurate protocols, we make no warranties, express or implied, regarding the fitness of this product for every specific experimental setup.

Technical Support: The protocols provided are for reference purposes. Unsure if this reagent suits your experiment?

Need Industrial/Bulk Grade? [Request Custom Synthesis Quote](#)

BenchChem

Our mission is to be the trusted global source of essential and advanced chemicals, empowering scientists and researchers to drive progress in science and industry.

Contact

Address: 3281 E Guasti Rd
Ontario, CA 91761, United States
Phone: (601) 213-4426
Email: info@benchchem.com

Contact our Ph.D. Support Team for a compatibility check