

An In-depth Technical Guide on the Discovery and Development of PNB-001

Author: BenchChem Technical Support Team. **Date:** April 2026

Compound of Interest

Compound Name: PNB-001

Cat. No.: B8263531

Get Quote

Introduction

PNB-001 (also known as GPP-Balacovin) is a first-in-class new chemical entity (NCE) identified as an arylated 5-hydroxy-pyrrol-2-one.[1] It has a unique dual mechanism of action, functioning as a Cholecystokinin-A (CCK-A) receptor agonist and a Cholecystokinin-B (CCK-B) receptor antagonist.[2][3] This profile confers potent anti-inflammatory, immunomodulatory, and analgesic properties.[1][4] Initially developed for inflammatory conditions like Inflammatory Bowel Disease (IBD) and pain, its development has been expanded to include infectious diseases such as COVID-19, where it has undergone Phase 2 and 3 clinical trials. This document provides a comprehensive technical overview of the discovery and development of **PNB-001**, detailing its pharmacology, preclinical data, and clinical findings.

Pharmacology and Mechanism of Action

PNB-001's therapeutic effects stem from its modulation of the cholecystokinin receptor system. The two primary CCK receptors, CCK-A ("alimentary") and CCK-B ("brain"), are distributed throughout the gastrointestinal (GI) tract and central nervous system (CNS). The peptide hormone gastrin also binds to the CCK-B receptor (also known as the CCK2 receptor), playing

a key role in gastric acid secretion, GI tract maturation, and cell proliferation. In pathological states such as IBD or certain cancers, excessive gastrin/CCK signaling can drive inflammation.

PNB-001 acts as a potent and selective antagonist at the CCK-B receptor, binding with an affinity of 20 nM. By blocking this receptor, it inhibits pro-inflammatory signaling pathways. Preclinical studies have shown it to be approximately ten times more potent than L-365,260, a standard CCK2 antagonist. Concurrently, **PNB-001** functions as a CCK-A agonist. This agonism is believed to contribute to its anti-inflammatory effects, potentially through the cholinergic anti-inflammatory pathway, and its analgesic properties. This dual action provides a unique approach to managing complex inflammatory diseases.

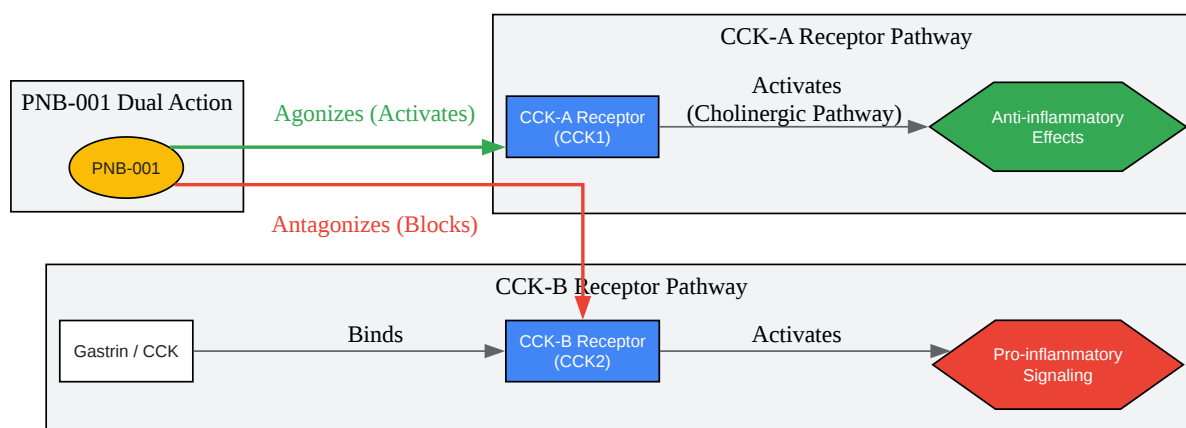

[Click to download full resolution via product page](#)

Caption: Proposed dual mechanism of action of **PNB-001**.

Preclinical Development

PNB-001 has undergone extensive preclinical evaluation to characterize its pharmacokinetic (PK), pharmacodynamic (PD), efficacy, and safety profiles.

Pharmacokinetics and ADME

Pharmacokinetic studies revealed species-dependent differences in metabolism. While **PNB-001** has a short half-life in rat liver microsomes, it is significantly more stable in dog and human liver microsomes, suggesting better bioavailability in humans. The compound exhibits high plasma protein binding but also shows high permeability in Caco-2 assays without being subject to efflux. Importantly, **PNB-001** showed no significant inhibition of major cytochrome P450 enzymes, indicating a low potential for drug-drug interactions.

Table 1: Preclinical Pharmacokinetics of **PNB-001**

Parameter	Species/System	Value	Reference
Half-life	Rat Liver Microsome	1.20 min	
	Dog/Human Liver Microsome	~12 min	
	Rat (in vivo, 20 mg/kg p.o.)	9 h	
Tmax	Rat (in vivo, 20 mg/kg p.o.)	40 min	

| Plasma Protein Binding| Rat and Human Plasma | 97% | |

Preclinical Efficacy

PNB-001 demonstrated robust efficacy in various animal models of pain and inflammation.

Table 2: Preclinical Efficacy of **PNB-001** in Pain Models

Model	Species	PNB-001 Dose	Comparator	Outcome	Reference
Tail-Flick Assay	Mice	0.5 mg/kg	40 mg/kg Tramadol	Comparable increase in latency	
Hot Plate Paw Withdrawal	Rats	5 mg/kg p.o.	40 mg/kg s.c. Tramadol	Superior efficacy to Tramadol	

| Formalin-Induced Pain | Rats | 1.5 mg/kg i.p. | Morphine | Effective in neuropathic phase (I) | |

Table 3: Preclinical Efficacy of **PNB-001** in an IBD Model

Model	Species	PNB-001 Dose (p.o.)	Comparator	Outcome	Reference

| Indomethacin-Induced IBD | Rats | 5 mg/kg & 20 mg/kg | Prednisolone | Completely reversed IBD and Crohn's disease-like damage | |

Preclinical Safety

Toxicology studies established a high safety margin for **PNB-001**.

Table 4: Preclinical Safety and ADME Profile of **PNB-001**

Study Type	Species	Dose	Findings	Reference
Maximum Tolerated Dose (MTD)	SD Rats	2000 mg/kg (oral)	LD50 >2000 mg/kg/day	
28-Day Toxicity	Rats	Up to 300 mg/kg	No treatment-related adverse effects	

| CYP450 Inhibition | In vitro | Up to 10 µM | No inhibition of Cyp3A4, Cyp2C9, Cyp1A2 | |

Experimental Protocols

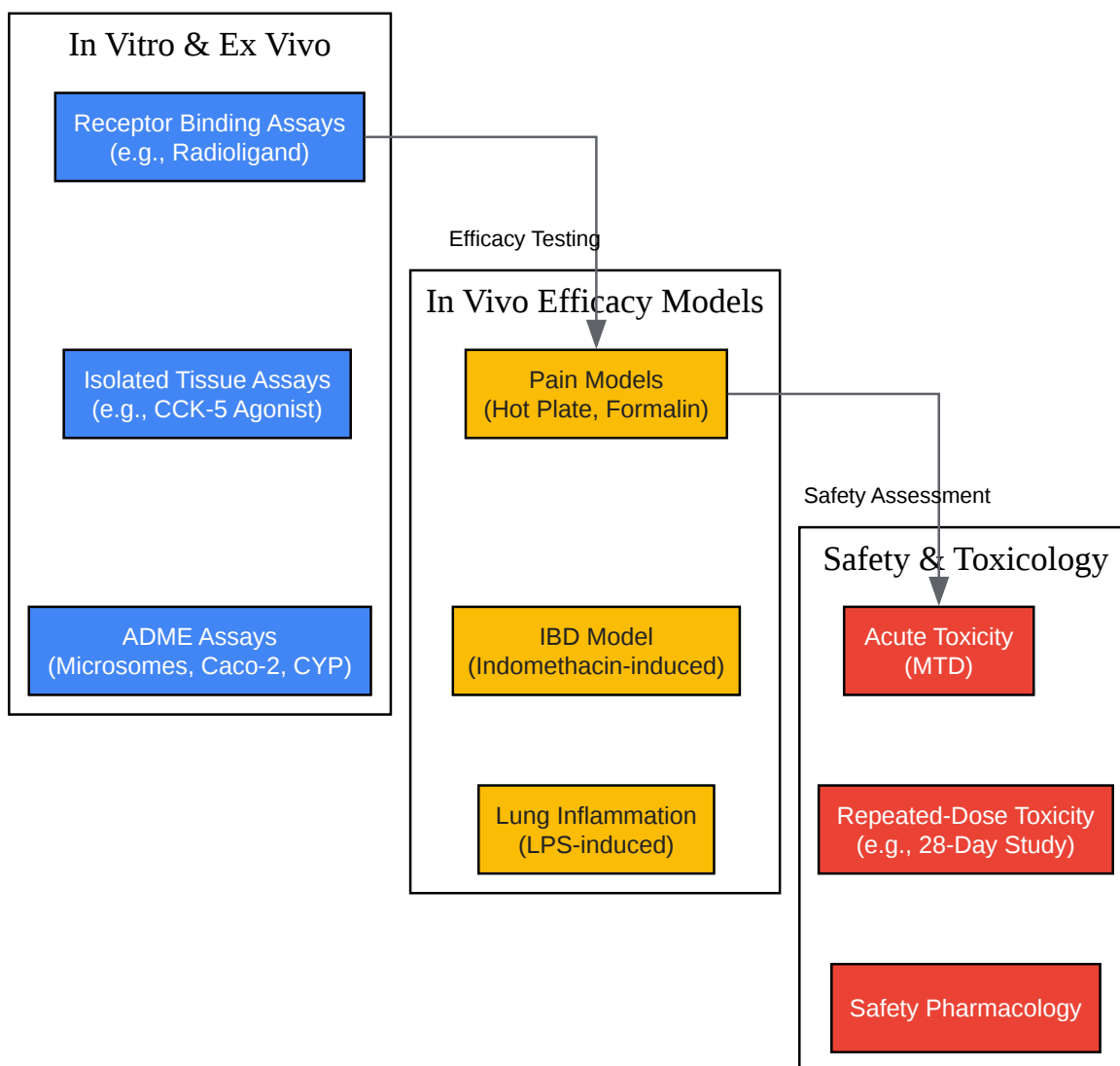

[Click to download full resolution via product page](#)

Caption: Generalized preclinical development workflow for **PNB-001**.

Protocol 1: Indomethacin-Induced IBD in Rats

- Objective: To evaluate the efficacy of **PNB-001** in a model of inflammatory bowel disease.

- Animals: Wistar rats.
- Induction: IBD is induced by subcutaneous administration of indomethacin.
- Treatment Groups:
 - Vehicle Control
 - Indomethacin Control
 - **PNB-001** (5 mg/kg, p.o.) + Indomethacin
 - **PNB-001** (20 mg/kg, p.o.) + Indomethacin
 - Prednisolone (positive control) + Indomethacin
- Procedure: Animals receive the respective treatments orally. Following treatment, gastrointestinal tissues and organs are collected.
- Endpoints: Assessment of inflammation and IBD-dependent damage through gross pathological examination and histopathological analysis of GI tissues.

Protocol 2: Formalin-Induced Pain in Rats

- Objective: To assess the analgesic efficacy of **PNB-001** in a model of tonic chemical pain with neuropathic and inflammatory components.
- Animals: Wistar rats.
- Procedure:
 - A dilute solution of formalin is injected into the plantar surface of the rat's hind paw.
 - Pain behavior (licking, flinching of the paw) is observed and quantified during two distinct phases: Phase I (0-5 minutes, neurogenic pain) and Phase II (15-60 minutes, inflammatory pain).
- Treatment Groups:

- Vehicle Control
- **PNB-001** (various doses, p.o. or i.p.)
- Morphine (positive control)
- Endpoints: Reduction in the duration of pain behaviors in Phase I and Phase II compared to the control group.

Protocol 3: LPS-Induced Lung Inflammation in Mice

- Objective: To evaluate the prophylactic and therapeutic effects of **PNB-001** on acute lung inflammation.
- Animals: Swiss albino mice.
- Treatment Groups (n=6 per group):
 - Vehicle Control: Received vehicle (35% PEG in distilled water).
 - LPS Control: Received intratracheal lipopolysaccharide (LPS, 10 μ g/mouse) to induce inflammation.
 - Treatment Group: Received LPS followed by oral **PNB-001** (100 mg/kg b.w.).
 - Prophylaxis Group: Received daily oral **PNB-001** (100 mg/kg b.w.) for 7 days, then induced with LPS.
- Endpoints:
 - Myeloperoxidase (MPO) Activity: Measured in lung tissue at 30 hours post-LPS induction as a marker of neutrophil infiltration.
 - Histopathology: Lungs examined for infiltration of inflammatory cells.

Clinical Development

PNB-001 has progressed to clinical trials, demonstrating a favorable safety profile in healthy volunteers and showing therapeutic efficacy in patients.

Phase 1 Studies

Single Ascending Dose (SAD) and Multiple Ascending Dose (MAD) studies were conducted in healthy subjects. **PNB-001** was found to be safe and well-tolerated across a wide dose range.

Table 5: Summary of Phase 1 (SAD) Clinical Trial of **PNB-001**

Parameter	Details	Reference
Population	42 healthy male subjects	
Dose Range	25 mg to 1500 mg	
Key PK Finding	Food effect: ~5-fold increase in C _{max} and ~4-fold increase in AUC with a high-fat meal.	

| Safety | Well-tolerated; AEs were mild. One subject withdrew due to a moderate AE. | |

Table 6: Summary of Phase 1 (MAD) Clinical Trial of **PNB-001**

Parameter	Details	Reference
Population	32 healthy subjects	
Doses	50, 100, and 200 mg daily for 14 days	
Half-life	Day 1: 2.4 - 6.8 hours; Day 14: 5.3 - 7.9 hours	

| Safety | Found to be safe; 2 AEs reported (vomiting, transient ALT increase at high dose). | |

Phase 2 COVID-19 Trial

A multi-center, randomized, open-label study was conducted to assess the efficacy and safety of **PNB-001** in patients with moderate COVID-19 infection.

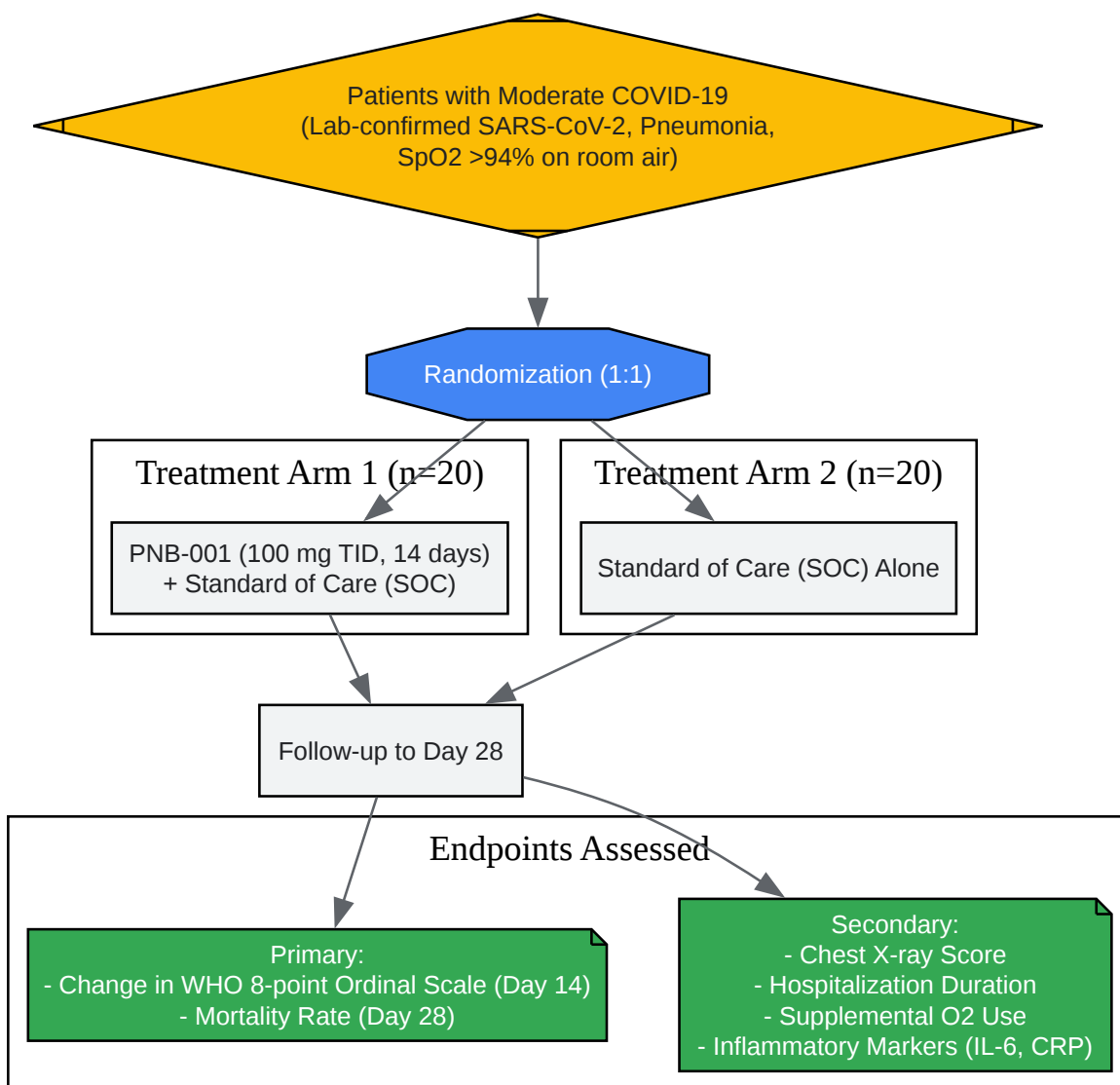

[Click to download full resolution via product page](#)

Caption: Workflow of the Phase 2 clinical trial of **PNB-001** in COVID-19.

Protocol 4: Phase 2 Trial in Moderate COVID-19 Patients

- Objective: To evaluate the efficacy and safety of **PNB-001** plus Standard of Care (SOC) compared to SOC alone.
- Design: Multi-center, randomized, parallel-group, comparative, open-label study.

- Participants: 40 patients with laboratory-confirmed moderate COVID-19, defined as having pneumonia with no signs of severe disease (SpO₂ >94% on room air).
- Intervention:
 - Test Arm (n=20): **PNB-001** (100 mg orally, three times daily for 14 days) + SOC.
 - Control Arm (n=20): SOC alone.
- Primary Endpoints:
 - Mean change in the 8-point WHO Ordinal Scale score from baseline by Day 14.
 - Mortality rate by Day 28.
- Key Secondary Endpoints: Improvement in chest X-ray, duration of hospitalization, duration of supplemental oxygen use, and change in inflammatory markers (e.g., IL-6, CRP, Neutrophil-Lymphocyte-Ratio).

Clinical Trial Results

The addition of **PNB-001** to standard care resulted in significant clinical improvements.

Table 7: Efficacy Outcomes of Phase 2 Clinical Trial of **PNB-001** in Moderate COVID-19 Patients

Endpoint	PNB-001 + SOC (n=20)	SOC Alone (n=20)	P-value	Reference
Change in WHO Ordinal Scale (Baseline to Day 14)	Significant Clinical Improvement	-	0.042	
Mean Chest X-ray Score Improvement	2.05	1.16	0.032	
Patients Remaining Hospitalized (Day 15)	1	5	0.048	

| Mortality by Day 28 | 1 patient | 2 patients | 0.56 | |

Table 8: Safety and Immunomodulatory Outcomes of Phase 2 Clinical Trial of **PNB-001** in Moderate COVID-19 Patients

Parameter	Finding	P-value	Reference
Adverse Events (AEs)	11 AEs in 8 patients (PNB-001 arm) vs. 13 AEs in 10 patients (SOC arm). No AEs were related to PNB-001.	-	
Lymphocyte Count	Increased into reference range	0.032	
Neutrophil Count	Reduced	0.013	

| Neutrophil-Lymphocyte-Ratio (NLR) | Significantly reduced | - | |

Conclusion

PNB-001 is a promising drug candidate with a novel dual mechanism targeting CCK receptors. The comprehensive preclinical data package demonstrated its efficacy in models of pain and inflammation with a wide safety margin. Clinical development has confirmed its safety in healthy volunteers and shown significant therapeutic benefits in patients with moderate COVID-19, highlighting its potent anti-inflammatory and immunomodulatory effects. These findings support the continued development of **PNB-001** for various inflammatory and infectious diseases. Phase 3 trials have been initiated to further confirm its efficacy in a larger patient population.

Need Custom Synthesis?

BenchChem offers custom synthesis for rare earth carbides and specific isotopic labeling.

Email: info@benchchem.com or [Request Quote Online](#).

References

- [1. jchps.com \[jchps.com\]](https://www.jchps.com)
- [2. PNB-001 - Drug Targets, Indications, Patents - Synapse \[synapse.patsnap.com\]](https://synapse.patsnap.com)
- [3. hospitalhealthcare.com \[hospitalhealthcare.com\]](https://www.hospitalhealthcare.com)
- [4. medrxiv.org \[medrxiv.org\]](https://www.medrxiv.org)
- To cite this document: BenchChem. [An In-depth Technical Guide on the Discovery and Development of PNB-001]. BenchChem, [2026]. [Online PDF]. Available at: [\[https://www.benchchem.com/product/b8263531/docs#an-in-depth-technical-guide-on-the-discovery-and-development-of-pnb-001\]](https://www.benchchem.com/product/b8263531/docs#an-in-depth-technical-guide-on-the-discovery-and-development-of-pnb-001)

Disclaimer & Data Validity:

The information provided in this document is for Research Use Only (RUO) and is strictly not intended for diagnostic or therapeutic procedures. While BenchChem strives to provide accurate protocols, we make no warranties, express or implied, regarding the fitness of this product for every specific experimental setup.

Technical Support: The protocols provided are for reference purposes. Unsure if this reagent suits your experiment?

Need Industrial/Bulk Grade? [Request Custom Synthesis Quote](#)

BenchChem

Our mission is to be the trusted global source of essential and advanced chemicals, empowering scientists and researchers to drive progress in science and industry.

Contact

Address: 3281 E Guasti Rd
Ontario, CA 91761, United States
Phone: (601) 213-4426
Email: info@benchchem.com

[Contact our Ph.D. Support Team for a compatibility check](#)