

# Technical Support Center: Ac4ManNAz-Labeled Protein Detection

**Author:** BenchChem Technical Support Team. **Date:** April 2026

## Compound of Interest

Compound Name: *N-Azidoacetylmannosamine*

Cat. No.: *B8255108*

[Get Quote](#)

Welcome to the technical support center for improving the detection sensitivity of Ac4ManNAz-labeled proteins. This resource provides researchers, scientists, and drug development professionals with troubleshooting guides and frequently asked questions (FAQs) to address common issues encountered during metabolic labeling and subsequent detection experiments.

## Frequently Asked Questions (FAQs) & Troubleshooting Guides

Here we address specific issues you might encounter during your experiments in a question-and-answer format.

**Q1:** I am observing a low signal from my Ac4ManNAz-labeled proteins. What are the potential causes and how can I improve the signal?

**A1:** Low signal is a common issue that can stem from several factors throughout the experimental workflow. Here's a troubleshooting guide to help you enhance your detection sensitivity:

- **Suboptimal Ac4ManNAz Concentration:** The concentration of Ac4ManNAz is critical. While higher concentrations may seem to promise more labeling, they can also induce cellular toxicity, leading to reduced protein synthesis and overall cell health.[1][2][3] Studies have shown that concentrations as high as 50  $\mu\text{M}$  can negatively impact cellular functions like proliferation and migration.[1][2][3] It is recommended to perform a dose-response curve to determine the optimal concentration for your specific cell line. A starting concentration of 10  $\mu\text{M}$  is often a good balance between labeling efficiency and cell viability.[1][2][3]
- **Insufficient Incubation Time:** Ensure that you are incubating your cells with Ac4ManNAz for a sufficient period. The metabolic incorporation of the sugar analog into glycoproteins is a time-dependent process. Typical incubation times range from 1 to 3 days.[4] You may need to optimize the incubation time for your cell type and experimental goals.
- **Inefficient Click Chemistry Reaction:** The efficiency of the click chemistry reaction is paramount for strong signal detection.
  - **Choice of Click Chemistry:** For live-cell imaging, it is crucial to use copper-free strain-promoted alkyne-azide cycloaddition (SPAAC) to avoid copper-induced cytotoxicity.[5][6] For fixed cells or lysates, copper(I)-catalyzed azide-alkyne cycloaddition (CuAAC) can be used and is often more rapid.
  - **Reagent Concentration:** Ensure you are using the recommended concentrations for your click chemistry reagents (e.g., DBCO-conjugated dyes). A typical concentration for DBCO-fluorophore is between 20-50  $\mu\text{M}$ . [4]
  - **Reaction Time and Temperature:** The click reaction is typically performed for 1 hour at 37°C.[4] These conditions can be optimized.
- **High Background Signal:** A high background can mask a weak signal.
  - **Washing Steps:** Thoroughly wash your cells after incubation with the detection reagent to remove any unbound fluorescent probes or biotin.
  - **Fluorogenic Probes:** Consider using fluorogenic azide or alkyne probes.[7] These probes only become fluorescent after the click reaction, significantly reducing background noise from unreacted probes.[7]

- Poor Enrichment of Labeled Proteins (for Mass Spectrometry): If you are performing proteomic analysis, inefficient enrichment of your labeled proteins will lead to low detection by mass spectrometry.
  - Biotinylation and Affinity Purification: Use a biotin-alkyne or biotin-DBCO reagent for the click reaction.[\[8\]](#)[\[9\]](#) The resulting biotinylated proteins can then be effectively enriched using streptavidin- or avidin-based affinity chromatography.[\[8\]](#)[\[9\]](#)

Q2: What is the optimal concentration of Ac4ManNAz to use for metabolic labeling?

A2: The optimal concentration of Ac4ManNAz can vary depending on the cell type and the desired outcome of the experiment. While manufacturers may recommend concentrations in the range of 25-75  $\mu\text{M}$ , several studies suggest that lower concentrations are often preferable to minimize effects on cell physiology.[\[10\]](#)[\[11\]](#)

Research has shown that a concentration of 50  $\mu\text{M}$  Ac4ManNAz can lead to a reduction in major cellular functions, including energy generation and cell infiltration abilities.[\[1\]](#)[\[2\]](#)[\[3\]](#) In contrast, a concentration of 10  $\mu\text{M}$  has been shown to have minimal effects on cellular systems while still providing sufficient labeling for cell tracking and proteomic analysis.[\[1\]](#)[\[2\]](#)[\[3\]](#) Therefore, it is highly recommended to perform a titration experiment to determine the ideal concentration for your specific cell line that balances labeling efficiency with cellular health.

Quantitative Data Summary: Effect of Ac4ManNAz Concentration on Cellular Functions

Ac4ManNAz Concentration	Effect on Cell Proliferation, Migration & Invasion	Effect on Glycolytic Flux & OCR	Labeling Efficiency	Recommendation
50 $\mu$ M	Decreased[1]	Reduced[1]	High	May introduce artifacts due to cellular stress.[1][2][3]
20 $\mu$ M	Gradual decrease observed[1]	Decreased[2]	Moderate-High	Use with caution; monitor cell health.
10 $\mu$ M	Least effect on cellular systems[1][2][3]	No significant changes compared to control[2]	Sufficient for cell tracking and proteomics[1][2][3]	Suggested optimal concentration for minimizing physiological effects.[1][2][3]

Q3: How do I choose the right detection reagent for my Ac4ManNAz-labeled proteins?

A3: The choice of detection reagent depends on your downstream application. The azide group on the incorporated sugar is the chemical handle for detection via click chemistry.[12]

- For Fluorescence Microscopy or Flow Cytometry: You will need a fluorescent probe conjugated to an alkyne (for CuAAC) or a strained alkyne like DBCO (for SPAAC).[4][5] A wide variety of fluorescent dyes are available, and the selection will depend on the excitation and emission capabilities of your imaging system. To minimize background, consider using fluorogenic probes that are non-fluorescent until they react with the azide.[7]
- For Western Blotting or Mass Spectrometry (Proteomics): A biotin-conjugated alkyne or DBCO reagent is the preferred choice.[8][9] After the click reaction, the biotinylated proteins can be detected on a Western blot using streptavidin-HRP or enriched from a cell lysate using streptavidin-coated beads for subsequent analysis by mass spectrometry.[8][13]

Q4: Can Ac4ManNAz labeling be toxic to my cells?

A4: Yes, at higher concentrations, Ac4ManNAz can exhibit cytotoxicity.[14] For example, Jurkat cells have been shown to be sensitive to 50  $\mu\text{M}$  Ac4ManNAz.[14] It is crucial to assess the health of your cells during the labeling period. Signs of toxicity can include changes in morphology, reduced proliferation rate, or increased cell death. If you observe any of these signs, you should reduce the concentration of Ac4ManNAz or the incubation time. As a general guideline, a concentration of 10  $\mu\text{M}$  is often well-tolerated by many cell lines.[1][2][3]

## Experimental Protocols

### Protocol 1: Metabolic Labeling of Cultured Cells with Ac4ManNAz

- **Cell Culture:** Plate your cells of interest on an appropriate culture vessel and grow them to the desired confluency.
- **Prepare Ac4ManNAz Stock Solution:** Dissolve Ac4ManNAz in sterile DMSO to prepare a stock solution (e.g., 10-50 mM).
- **Labeling:** Add the Ac4ManNAz stock solution to the cell culture medium to achieve the desired final concentration (e.g., 10  $\mu\text{M}$ ).
- **Incubation:** Incubate the cells for 1-3 days under standard culture conditions (37°C, 5% CO<sub>2</sub>).
- **Harvesting:** After incubation, wash the cells with PBS to remove any residual Ac4ManNAz. The cells are now ready for the click chemistry reaction.

### Protocol 2: Detection of Azide-Labeled Proteins via SPAAC with a DBCO-Fluorophore

- **Prepare Labeled Cells:** Follow Protocol 1 to label your cells with Ac4ManNAz.
- **Prepare DBCO-Fluorophore Solution:** Prepare a stock solution of the DBCO-conjugated fluorescent dye in DMSO. Dilute the stock solution in serum-free media or PBS to the desired final concentration (e.g., 20-50  $\mu\text{M}$ ).
- **Click Reaction:** Add the DBCO-fluorophore solution to the azide-labeled cells and incubate for 1 hour at 37°C.
- **Washing:** Wash the cells three times with PBS to remove any unreacted DBCO-fluorophore.

- Imaging: The cells are now fluorescently labeled and can be visualized by fluorescence microscopy or analyzed by flow cytometry. For microscopy, you can proceed with fixation and counterstaining (e.g., with DAPI) if desired.

## Visualizations

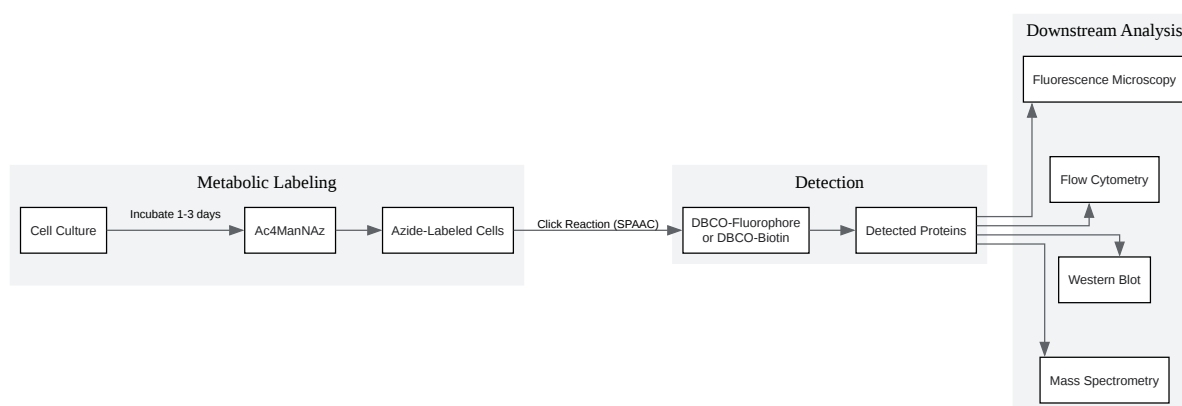

[Click to download full resolution via product page](#)

Caption: Experimental workflow for Ac4ManNAz labeling and detection.

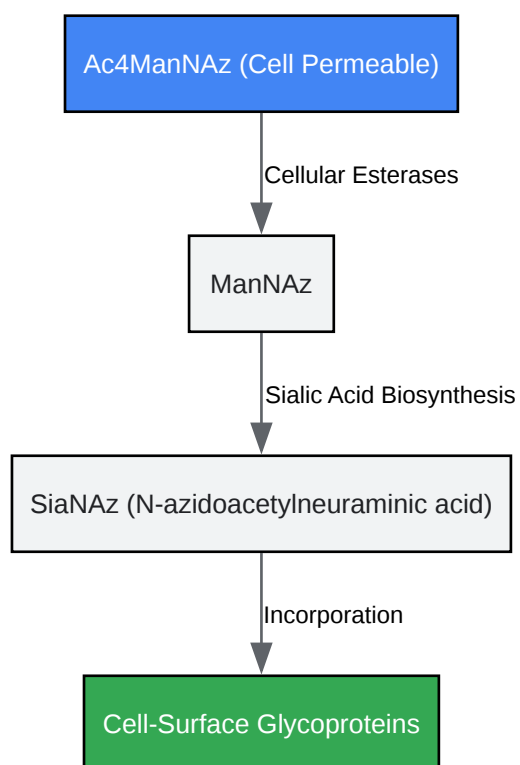

[Click to download full resolution via product page](#)

Caption: Metabolic pathway of Ac4ManNAz incorporation into glycoproteins.

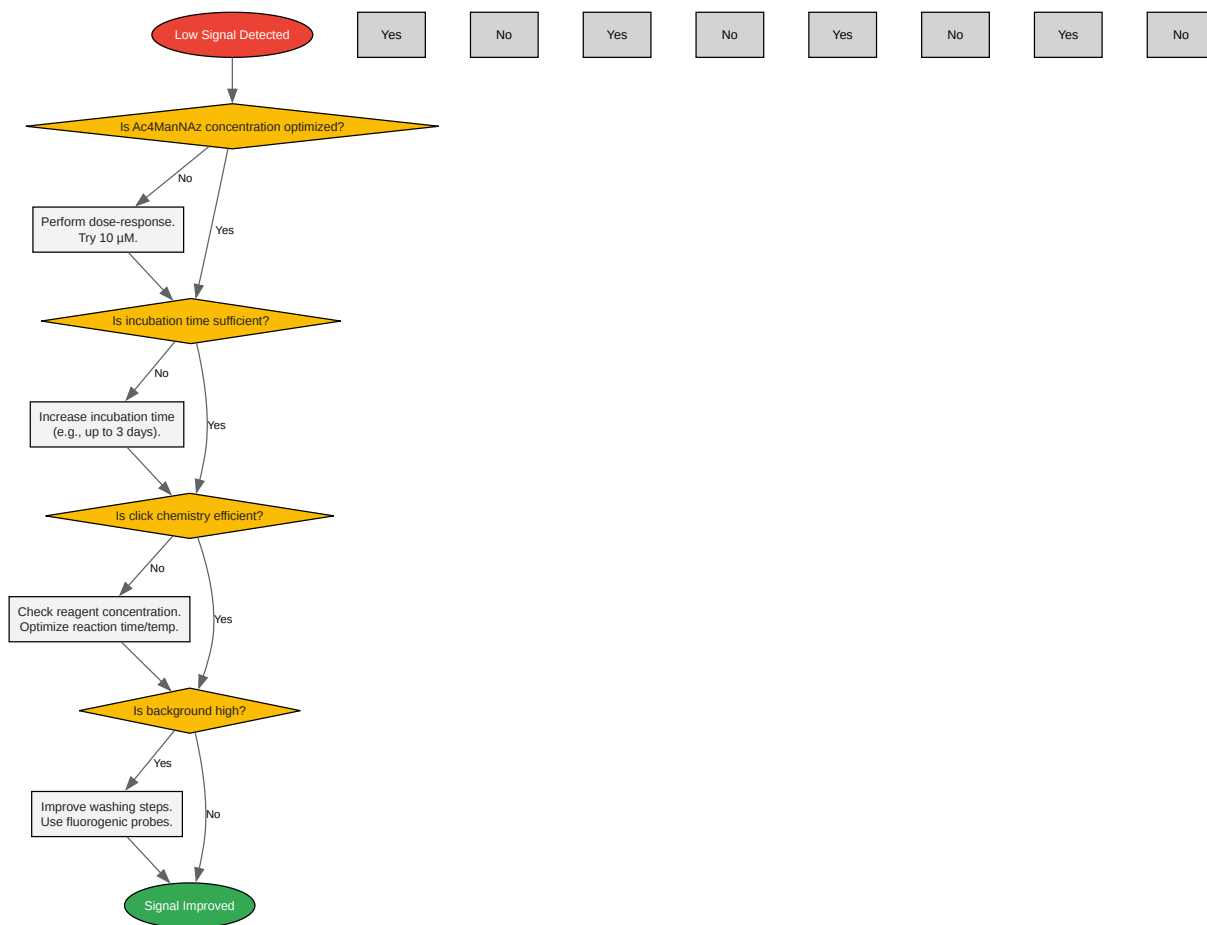

[Click to download full resolution via product page](#)

Caption: Troubleshooting logic for low signal in Ac4ManNAz experiments.

**Need Custom Synthesis?**

BenchChem offers custom synthesis for rare earth carbides and specific isotopic labeling.

Email: [info@benchchem.com](mailto:info@benchchem.com) or [Request Quote Online](#).

## References

- 1. Physiological Effects of Ac4ManNAz and Optimization of Metabolic Labeling for Cell Tracking - PMC [[pmc.ncbi.nlm.nih.gov](https://pubmed.ncbi.nlm.nih.gov/)]
- 2. [researchgate.net](https://www.researchgate.net/) [[researchgate.net](https://www.researchgate.net/)]
- 3. Physiological Effects of Ac4ManNAz and Optimization of Metabolic Labeling for Cell Tracking - PubMed [[pubmed.ncbi.nlm.nih.gov](https://pubmed.ncbi.nlm.nih.gov/)]
- 4. [benchchem.com](https://www.benchchem.com/) [[benchchem.com](https://www.benchchem.com/)]
- 5. [medchemexpress.com](https://www.medchemexpress.com/) [[medchemexpress.com](https://www.medchemexpress.com/)]
- 6. [licorbio.com](https://www.licorbio.com/) [[licorbio.com](https://www.licorbio.com/)]
- 7. [2bscientific.com](https://www.2bscientific.com/) [[2bscientific.com](https://www.2bscientific.com/)]
- 8. Biotinylation and Haptenylation Reagents—Section 4.2 | Thermo Fisher Scientific - HK [[thermofisher.com](https://www.thermofisher.com/)]
- 9. Biotinylation Reagents [[sigmaaldrich.com](https://www.sigmaaldrich.com/)]
- 10. Ac4ManNAz, Click Reagents for Glycosylation - Jena Bioscience [[jenabioscience.com](https://www.jenabioscience.com/)]
- 11. [lumiprobe.com](https://www.lumiprobe.com/) [[lumiprobe.com](https://www.lumiprobe.com/)]
- 12. [vectorlabs.com](https://www.vectorlabs.com/) [[vectorlabs.com](https://www.vectorlabs.com/)]
- 13. Targeted glycoprotein enrichment and identification in stromal cell secretomes using azido sugar metabolic labeling - PMC [[pmc.ncbi.nlm.nih.gov](https://pubmed.ncbi.nlm.nih.gov/)]
- 14. [pubs.acs.org](https://pubs.acs.org/) [[pubs.acs.org](https://pubs.acs.org/)]
- To cite this document: BenchChem. [Technical Support Center: Ac4ManNAz-Labeled Protein Detection]. BenchChem, [2026]. [Online PDF]. Available at: [<https://www.benchchem.com/product/b8255108/docs#technical-support-center-ac4mannaz-labeled-protein-detection>]

---

**Disclaimer & Data Validity:**

The information provided in this document is for Research Use Only (RUO) and is strictly not intended for diagnostic or therapeutic procedures. While BenchChem strives to provide accurate protocols, we make no warranties, express or implied, regarding the fitness of this product for every specific experimental setup.

**Technical Support:** The protocols provided are for reference purposes. Unsure if this reagent suits your experiment?

**Need Industrial/Bulk Grade?** [Request Custom Synthesis Quote](#)

## BenchChem

Our mission is to be the trusted global source of essential and advanced chemicals, empowering scientists and researchers to drive progress in science and industry.

### Contact

Address: 3281 E Guasti Rd  
Ontario, CA 91761, United States  
Phone: (601) 213-4426  
Email: [info@benchchem.com](mailto:info@benchchem.com)

[Contact our Ph.D. Support Team for a compatibility check](#)