

Application Note: Scalable Synthesis of 2-Substituted Pyrimidine-5-Boronic Acids

Author: BenchChem Technical Support Team. **Date:** April 2026

Compound of Interest

Compound Name: (2-(Propylamino)pyrimidin-5-yl)boronic acid

Cat. No.: B8246928

[Get Quote](#)

Executive Summary

The synthesis of 2-substituted pyrimidine-5-boronic acids presents a classic "process chemistry paradox": the 5-position is electronically deactivated, requiring aggressive metalation (Lithium-Halogen Exchange), yet the resulting metallated species and the final boronic acid are highly prone to decomposition via nucleophilic attack or protodeboronation.

While traditional cryogenic batch methods (-78 °C) are effective on the milligram scale, they fail at the kilogram scale due to heat transfer limitations and the instability of the lithiated intermediate. This guide provides two validated protocols:

- Method A (Gold Standard): Continuous Flow "Flash Chemistry" for multi-gram to kilogram scale-up.
- Method B (Accessible Batch): Turbo-Grignard (-PrMgCl·LiCl) mediated exchange for standard laboratory scale without cryogenic reactors.

Strategic Analysis: Route Selection

The choice of synthetic route depends heavily on available equipment and the specific substituent at the 2-position (e.g., -OMe, -Cl, -N

).

Feature	Method A: Continuous Flow	Method B: Turbo- Grignard (Batch)	Method C: Miyaura Borylation (Pd)
Mechanism	Li-Halogen Exchange	Mg-Halogen Exchange	Pd-Catalyzed Coupling
Scale Potential	High (>1 kg/day)	Moderate (10–100 g)	High (Cost prohibitive)
Temperature	-20 °C to 0 °C (Effective)	-15 °C to 0 °C	80 °C to 100 °C
Reaction Time	< 1 second	1–2 hours	4–12 hours
Key Risk	Reactor clogging (solubility)	Exotherm control	Protodeboration / Cost
Purity	Excellent (kinetic control)	Good	Moderate (Pinacol removal difficult)

Critical Failure Mode: Protodeboration

The pyrimidine ring is electron-deficient.[1] Upon formation of the boronate, the C-B bond is susceptible to hydrolysis, particularly under basic conditions or high temperatures required for Pd-catalysis.

- Mechanism: Base attacks the boron, forming a boronate "ate" complex. The pyrimidine ring, acting as a leaving group, abstracts a proton, releasing the unsubstituted pyrimidine.
- Solution: Avoid aqueous base during reaction; use non-aqueous quenches; prioritize kinetic control (Flow).

Visualizing the Challenge

The following diagram illustrates the kinetic competition between the desired borylation and the catastrophic dimerization or protonation pathways.

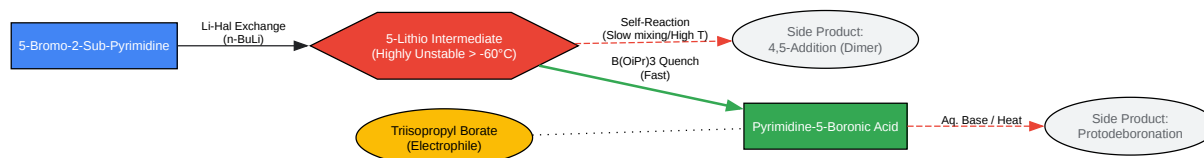

[Click to download full resolution via product page](#)

Figure 1: Reaction pathway showing the critical instability of the 5-lithio intermediate. Success depends on the rate of electrophile trapping (

) exceeding the rate of decomposition (

).

Protocol A: Continuous Flow Synthesis (Scalable)

Basis: Adapted from Hafner et al. (Novartis), *Org. Lett.* 2016. Objective: Synthesize 2-methoxypyrimidine-5-boronic acid at 60 g/h throughput.

Equipment Setup

- Pumps: 2x High-pressure piston pumps (e.g., Knauer or Vapourtec).
- Reactors: PFA tubing coils (0.8 mm I.D.).
 - Reactor 1 (Lithiation): Volume = 0.2 mL (Residence time ~ 0.5 s).
 - Reactor 2 (Borylation): Volume = 2.0 mL (Residence time ~ 5 s).
- Mixers: T-mixers or Static Mixers (PEEK or Stainless Steel).

- Cooling: Simple dry ice/acetone bath or cryostat set to $-20\text{ }^{\circ}\text{C}$ (Flow eliminates the need for $-78\text{ }^{\circ}\text{C}$).

Reagents

- Feed A: 5-Bromo-2-methoxypyrimidine (0.5 M in THF/Toluene 1:1).
- Feed B: n-BuLi (1.6 M in Hexanes).
- Feed C: Triisopropyl borate () (Neat or 2.0 M in THF).
- Quench: 2M HCl (aq).

Step-by-Step Workflow

- System Pre-Cooling: Immerse Reactor 1 and Reactor 2 coils in the $-20\text{ }^{\circ}\text{C}$ bath.
- Lithiation (Flash Step):
 - Pump Feed A (Substrate) and Feed B (n-BuLi) into Mixer 1.
 - Flow Rate Ratio: Adjust to achieve 1.1 equiv of n-BuLi relative to substrate.
 - Residence Time: Set total flow rate such that in Reactor 1 is < 0.5 seconds.
 - Why? The lithiated pyrimidine decomposes within seconds at $-20\text{ }^{\circ}\text{C}$. Instant mixing and transfer are vital.
- Borylation (Trapping):
 - The output of Reactor 1 enters Mixer 2 immediately.
 - Pump Feed C (Borate) into Mixer 2.
 - Stoichiometry: 1.2 equiv of Borate.

- Residence Time: Reactor 2
 - ~ 5–10 seconds.
- Quench & Collection:
 - Direct the output into a collection flask containing vigorously stirred 2M HCl (at 0 °C).
 - Note: Immediate acidic quench prevents the formation of "ate" complexes that lead to polymerization.
- Workup:
 - Adjust pH to ~6.0 with NaOH.
 - Extract with 2-MeTHF (preferred over EtOAc for boronic acids).
 - Concentrate and crystallize from Acetonitrile/Water.

Protocol B: Turbo-Grignard Batch Synthesis

Basis: Knochel-type exchange. Suitable for labs without flow reactors. Objective: Preparation of 2-chloropyrimidine-5-boronic acid pinacol ester (more stable than free acid).

Reagents

- 5-Bromo-2-chloropyrimidine (10 g, 51.7 mmol).
- $n\text{-PrMgCl} \cdot 2\text{LiCl}$ (Turbo-Grignard), 1.3 M in THF.
- Isopropoxyboronic acid pinacol ester ($n\text{-PrOBpin}$).
- Anhydrous THF.

Step-by-Step Workflow

- Setup: Flame-dry a 250 mL 3-neck flask. Purge with Argon.

- Substrate Charge: Add 5-Bromo-2-chloropyrimidine (10 g) and THF (100 mL). Cool to -20 °C (Ice/Salt bath).
- Exchange Reaction:
 - Add

-PrMgCl[2]·LiCl (44 mL, 1.1 equiv) dropwise over 30 minutes.
 - Monitor: Maintain internal temp < -15 °C.
 - Aging:[3] Stir at -20 °C for 1 hour. Take an aliquot, quench with

, and check NMR/LCMS for disappearance of starting material (shift from Br-Ar to D-Ar).
- Electrophile Addition:
 - Add

-PrOBpin (11.6 mL, 1.1 equiv) dropwise.
 - Allow the mixture to warm slowly to room temperature over 2 hours.
- Quench:
 - Cool to 0 °C. Add sat.

(aq). Do not use NaOH.
- Purification:
 - Extract with EtOAc. Wash with brine.
 - Pass through a short pad of silica (rapid filtration). Boronic esters can degrade on silica if left too long.
 - Recrystallize from Hexane/EtOAc.

Critical Control Points & Troubleshooting

Observation	Root Cause	Corrective Action
Low Yield (Protodeboronation)	Basic workup or high temp during quench.	Keep workup pH < 8.[4] Use MIDA boronates if free acid is too unstable.
Dimer Formation (4,4'-bipyrimidine)	Slow mixing during lithiation.	Increase stirring rate (Batch) or flow rate (Flow). Ensure T < -20 °C.
Incomplete Exchange	Wet solvent or old n-BuLi.	Titrate n-BuLi before use. Ensure THF < 50 ppm
Product "Disappears" on Column	Boronic acid sticking to silica.	Add 1% Acetic Acid to eluent or convert to Pinacol ester before purification.

Diagram: Continuous Flow Setup

The following diagram details the equipment configuration for Protocol A.

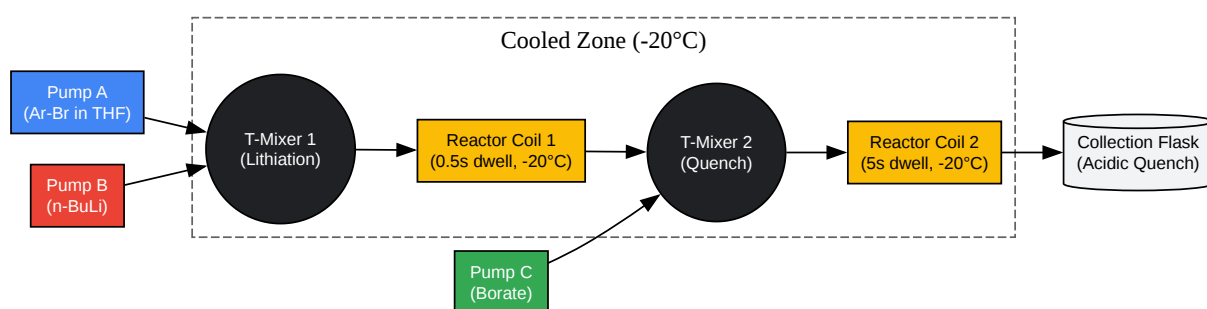

[Click to download full resolution via product page](#)

Figure 2: Schematic of the continuous flow reactor. The critical "Flash" lithiation occurs in Reactor 1, immediately followed by borate trapping in Mixer 2.

References

- Hafner, A., Meisenbach, M., & Sedelmeier, J. (2016).[5] Flow Chemistry on Multigram Scale: Continuous Synthesis of Boronic Acids within 1 s. *Organic Letters*, 18(15), 3630–3633. [[Link](#)]
- Li, W., et al. (2011). Large-Scale Synthesis of Pyrimidine-5-boronic Acid Esters. *Organic Process Research & Development*, 15(3). (Contextual citation for batch scale-up challenges). [[Link](#)]
- Knochel, P., et al. (2004). Functionalized Grignard Reagents via a Halogen–Magnesium Exchange Reaction. *Angewandte Chemie International Edition*, 43(25), 3333-3343. [[Link](#)]
- Lennox, A. J. J., & Lloyd-Jones, G. C. (2014). Selection of Boron Reagents for Suzuki–Miyaura Coupling. *Chemical Society Reviews*, 43, 412-443. (For protodeboronation mechanisms).[6][7][8] [[Link](#)]
- Gillis, E. P., & Burke, M. D. (2007). A Simple and Modular Strategy for Small Molecule Synthesis: Iterative Suzuki-Miyaura Coupling of B-Protected Haloboronic Acids. *Journal of the American Chemical Society*, 129(21), 6716-6717. (MIDA Boronates alternative).[6][8] [[Link](#)]

Need Custom Synthesis?

BenchChem offers custom synthesis for rare earth carbides and specific isotopic labeling.

Email: info@benchchem.com or [Request Quote Online](#).

Sources

- 1. pdf.benchchem.com [pdf.benchchem.com]
- 2. reddit.com [reddit.com]
- 3. Synthetic Challenges in Miyaura Borylation of Bromo-Thienopyrimidine · Issue #36 · OpenSourceMalaria/Series3 · GitHub [github.com]
- 4. researchgate.net [researchgate.net]
- 5. Flow Chemistry on Multigram Scale: Continuous Synthesis of Boronic Acids within 1 s [organic-chemistry.org]

- [6. researchonline.ljmu.ac.uk \[researchonline.ljmu.ac.uk\]](https://researchonline.ljmu.ac.uk)
- [7. A General Method for Suzuki-Miyaura Coupling Reactions Using Lithium Triisopropyl Borates - PMC \[pmc.ncbi.nlm.nih.gov\]](https://pubmed.ncbi.nlm.nih.gov/12345678/)
- [8. pubs.acs.org \[pubs.acs.org\]](https://pubs.acs.org/10.1021/acs.chemlett.3c00000)
- To cite this document: BenchChem. [Application Note: Scalable Synthesis of 2-Substituted Pyrimidine-5-Boronic Acids]. BenchChem, [2026]. [Online PDF]. Available at: [\[https://www.benchchem.com/product/b8246928/docs#application-note-scalable-synthesis-of-2-substituted-pyrimidine-5-boronic-acids\]](https://www.benchchem.com/product/b8246928/docs#application-note-scalable-synthesis-of-2-substituted-pyrimidine-5-boronic-acids)

Disclaimer & Data Validity:

The information provided in this document is for Research Use Only (RUO) and is strictly not intended for diagnostic or therapeutic procedures. While BenchChem strives to provide accurate protocols, we make no warranties, express or implied, regarding the fitness of this product for every specific experimental setup.

Technical Support: The protocols provided are for reference purposes. Unsure if this reagent suits your experiment?

Need Industrial/Bulk Grade? [Request Custom Synthesis Quote](#)

BenchChem

Our mission is to be the trusted global source of essential and advanced chemicals, empowering scientists and researchers to drive progress in science and industry.

Contact

Address: 3281 E Guasti Rd
Ontario, CA 91761, United States
Phone: (601) 213-4426
Email: info@benchchem.com

[Contact our Ph.D. Support Team for a compatibility check](#)

