

Application Note: Precision Solvent Engineering for Suzuki-Miyaura Coupling of Nitrogen Heterocycles

Author: BenchChem Technical Support Team. **Date:** April 2026

Compound of Interest

Compound Name: (2-(Propylamino)pyrimidin-5-yl)boronic acid

Cat. No.: B8246928

[Get Quote](#)

Executive Summary

The Suzuki-Miyaura cross-coupling of nitrogen heterocycles (pyridines, pyrimidines, indoles) presents a dichotomy: the conditions required to accelerate the rate-determining transmetallation step often accelerate the decomposition of unstable heterocyclic boronic acids (protodeboronation). Furthermore, nitrogen-containing substrates frequently poison palladium catalysts via competitive coordination.

This guide moves beyond "try Dioxane/Water" to provide a mechanistic rationale for solvent selection. We prioritize Green Chemistry alternatives (2-MeTHF, CPME) alongside traditional systems, providing a decision matrix to balance solubility, reaction rate, and substrate stability.

Mechanistic Insight: The Solvent's Role in Transmetallation

In N-heterocyclic couplings, the solvent is not merely a medium; it is an active participant in the catalytic cycle.

The "Suzuki Effect" vs. Protodeboronation

Water and polar protic co-solvents play a dual role.

- Activation (Good): Water/Base converts the boronic acid ($R-B(OH)_2$) into the reactive hydroxyboronate species ($[R-B(OH)_3]^-$). This species undergoes transmetalation to Palladium significantly faster than the neutral acid.
- Decomposition (Bad): The same basic, aqueous conditions facilitate protodeboronation, particularly in 2-substituted nitrogen heterocycles (e.g., 2-pyridineboronic acid). The basic nitrogen facilitates a mechanism where the C-B bond is cleaved by water.

The Engineering Challenge: You must select a solvent system that maintains a high concentration of the active hydroxyboronate for transmetalation while minimizing the "standing time" of this unstable species.

Diagram 1: Solvent Influence on Catalytic Pathways

This diagram illustrates the bifurcation between productive coupling and catalyst poisoning/substrate decomposition.

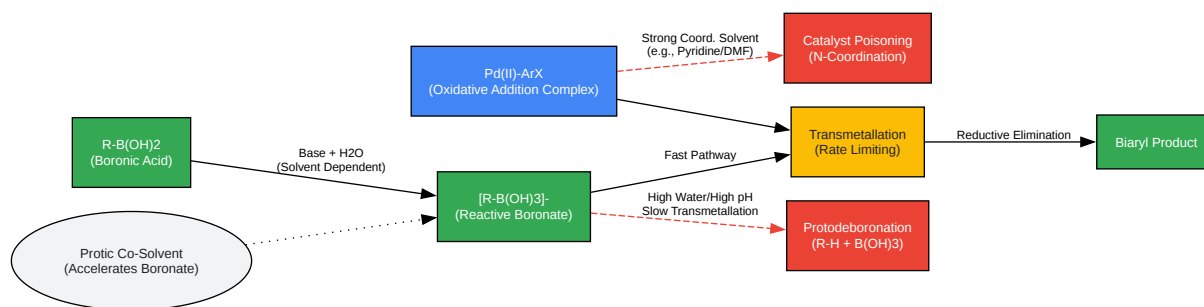

[Click to download full resolution via product page](#)

Caption: The "Goldilocks" Zone: Solvents must promote Boronate formation (Green path) without enabling Poisoning or Decomposition (Red paths).

Solvent Selection Matrix

Do not default to DMF. Use this matrix to select the optimal solvent based on your specific electrophile and nucleophile properties.

Substrate Class	Recommended Solvent System	Rationale	Green Alternative
Standard N-Heterocycles (e.g., 3-pyridyl, indoles)	1,4-Dioxane / Water (4:1)	The industry standard. Excellent solubility for Pd-catalysts and inorganic bases.	2-MeTHF / Water Higher boiling point than THF; separates easily from water for workup.
Unstable Boronic Acids (e.g., 2-pyridyl, 2-pyrimidyl)	DME / Water (10:1) or Toluene / n-BuOH (4:1)	Reduced water content slows protodeboronation. n-Butanol provides necessary protic activation without bulk water.	CPME / Water Low water miscibility protects the boronic acid in the organic phase until reaction.
Polar/Insoluble Substrates (e.g., fused ring systems)	n-Butanol or DMA	High solubility for polar heterocycles. Alcohols can act as both solvent and activator.	Anisole or Ethyl Lactate (Screening required for solubility).
Lipophilic Substrates	Toluene / Water (10:1)	Biphasic system protects catalyst from polar poisons. Requires Phase Transfer Catalyst (e.g., TBAB).	p-Cymene A bio-derived equivalent to Toluene.

Experimental Protocols

Protocol A: The "Green-First" General Screening

Use this for standard library synthesis where extreme instability is not expected.

Reagents:

- Solvent: 2-MeTHF (2-Methyltetrahydrofuran) saturated with water.
- Base:

(2.0 equiv, finely ground).
- Catalyst: XPhos Pd G4 (2-3 mol%) - Selected for resistance to N-poisoning.

Workflow:

- Preparation: Charge a reaction vial with the aryl halide (1.0 equiv), boronic acid (1.2 equiv), and Base (2.0 equiv).
- Solvation: Add 2-MeTHF (concentration 0.2 M). Note: 2-MeTHF forms an azeotrope with water; adding 5% v/v water explicitly is recommended if using anhydrous solvent.
- Inertion: Purge headspace with Nitrogen/Argon for 2 minutes.
- Catalyst Addition: Add Pd precatalyst (stock solution in 2-MeTHF or solid).
- Reaction: Seal and heat to 60°C. Monitor via LCMS at 1 hour.
 - Why 60°C? 2-MeTHF boils at 80°C. 60°C prevents pressure buildup while ensuring rate.
- Workup: Dilute with water and EtOAc. The 2-MeTHF layer will separate cleanly (unlike THF/Dioxane which require salting out).

Protocol B: The "Rapid Injection" for Unstable 2-Pyridyl Boronates

Use this when the boronic acid is prone to rapid protodeboronation (2-position substitution).

Concept: Minimize the time the boronic acid spends in the basic aqueous phase before meeting the Palladium.

Reagents:

- Solvent: 1,4-Dioxane (Anhydrous) and Water (Degassed).
- Base:
(3.0 equiv).
- Catalyst:
(5 mol%) - High activity for difficult substrates.

Workflow:

- Catalyst Pot: In the main reaction vessel, combine Aryl Halide (1.0 equiv), Base (3.0 equiv), and Catalyst (5 mol%) in Dioxane/Water (5:1 ratio). Heat this mixture to 90°C before adding the boron species.
- Boronate Solution: In a separate syringe or vial, dissolve the unstable 2-pyridyl boronic acid (1.5 equiv) in pure, anhydrous Dioxane.
- Slow Addition: Using a syringe pump or portion-wise addition, add the Boronate solution to the hot Catalyst Pot over 30–60 minutes.
 - Mechanism:^[1]^[2]^[3]^[4]^[5]^[6]^[7] This keeps the instantaneous concentration of the boronic acid low relative to the catalyst, favoring Transmetallation () over Protodeboronation ().
- Quench: Immediately cool upon completion of addition and 10 min soak.

Decision Tree for Process Optimization

Use this logic flow to troubleshoot low yields.

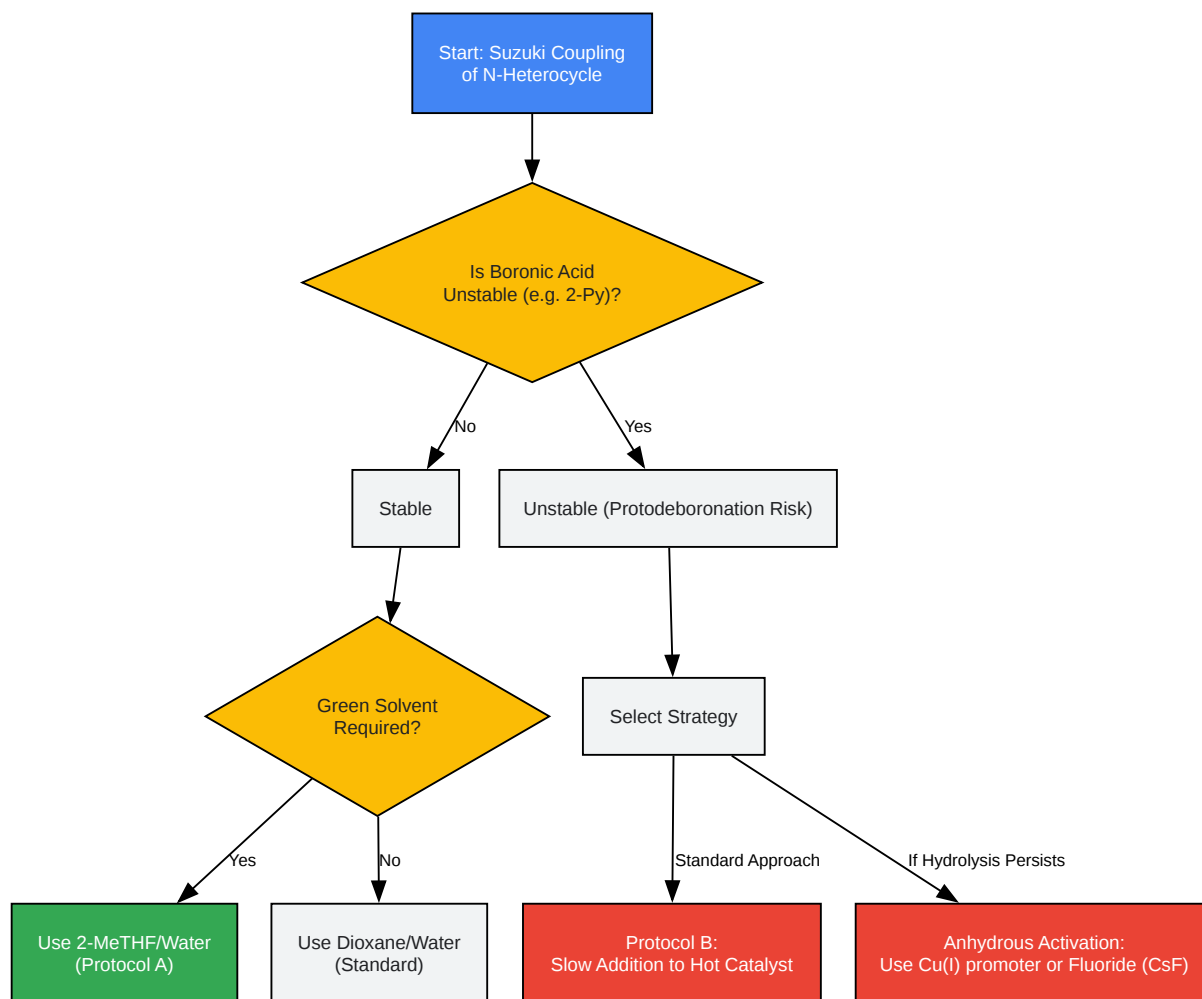

[Click to download full resolution via product page](#)

Caption: Selection logic prioritizing substrate stability and environmental constraints.

Troubleshooting Guide

Observation	Root Cause	Solvent/Protocol Adjustment
Protodeboronation (Ar-H detected)	Water concentration too high or pH too high.	Switch to Protocol B (Slow addition). Reduce water ratio (e.g., Dioxane/Water 10:1). Switch base to (milder than Carbonates).
No Reaction (SM Recovery)	Catalyst poisoning by N-heterocycle.	Increase Temperature (>80°C). [8][9] Switch to n-Butanol (high solubility/activation). Use Buchwald precatalysts (XPhos, SPhos).
Homocoupling (Ar-Ar)	Oxidative induced coupling.	Degas solvents thoroughly (Freeze-Pump-Thaw). Ensure solvent is not absorbing oxygen (common in Ethers).
Precipitation	Poor solubility of zwitterionic intermediates.	Add a polar co-solvent (DMF/DMA) at 10% volume. Or use Toluene/n-Butanol mixtures.

References

- Mechanistic Studies on Transmetalation: Carrow, B. P., & Hartwig, J. F. (2011). "Distinguishing Between Pathways for Transmetalation in Suzuki-Miyaura Reactions." *Journal of the American Chemical Society*.[\[4\]](#)[\[5\]](#)
- Green Solvent Selection: Lei, P., et al. (2021).[\[10\]](#) "Green Solvent Selection for Suzuki-Miyaura Coupling of Amides." *ACS Sustainable Chemistry & Engineering*.[\[10\]](#) [\[10\]](#)[\[11\]](#)
- Protodeboronation of 2-Pyridyl Boronates: Cox, P. A., et al. (2016). "Protodeboronation of Heteroaromatic Boronic Acids." *Angewandte Chemie International Edition*.

- High Throughput Screening: Krska, S. W., et al. (2022). "Nanomole-scale high-throughput chemistry for the synthesis of complex molecules." *Science*.
- Process Chemistry Guide: Dunetz, J. R., Magano, J., & Weisenburger, G. A. (2016). "Large-Scale Applications of Amide Coupling Reagents for the Synthesis of Pharmaceuticals." *Organic Process Research & Development*.

Need Custom Synthesis?

BenchChem offers custom synthesis for rare earth carbides and specific isotopic labeling.

Email: info@benchchem.com or [Request Quote Online](#).

Sources

- 1. Yoneda Labs [yonedalabs.com]
- 2. researchgate.net [researchgate.net]
- 3. Suzuki Coupling [organic-chemistry.org]
- 4. chembites.org [chembites.org]
- 5. dspace.mit.edu [dspace.mit.edu]
- 6. Protodeboronation - Wikipedia [en.wikipedia.org]
- 7. researchgate.net [researchgate.net]
- 8. Synthesis of 2-arylpyridines by the Suzuki–Miyaura cross-coupling of PyFluor with hetero(aryl) boronic acids and esters - PMC [[pmc.ncbi.nlm.nih.gov](https://pubmed.ncbi.nlm.nih.gov)]
- 9. Protodeboronation [organic-chemistry.org]
- 10. researchwithrutgers.com [researchwithrutgers.com]
- 11. pubs.acs.org [pubs.acs.org]
- To cite this document: BenchChem. [Application Note: Precision Solvent Engineering for Suzuki-Miyaura Coupling of Nitrogen Heterocycles]. BenchChem, [2026]. [Online PDF]. Available at: [<https://www.benchchem.com/product/b8246928/docs#application-note-precision-solvent-engineering-for-suzuki-miyaura-coupling-of-nitrogen-heterocycles>]

Disclaimer & Data Validity:

The information provided in this document is for Research Use Only (RUO) and is strictly not intended for diagnostic or therapeutic procedures. While BenchChem strives to provide accurate protocols, we make no warranties, express or implied, regarding the fitness of this product for every specific experimental setup.

Technical Support: The protocols provided are for reference purposes. Unsure if this reagent suits your experiment?

Need Industrial/Bulk Grade? [Request Custom Synthesis Quote](#)

BenchChem

Our mission is to be the trusted global source of essential and advanced chemicals, empowering scientists and researchers to drive progress in science and industry.

Contact

Address: 3281 E Guasti Rd
Ontario, CA 91761, United States
Phone: (601) 213-4426
Email: info@benchchem.com

[Contact our Ph.D. Support Team for a compatibility check](#)