

Advanced Architectures of 3,6-Substituted Carbazole Derivatives for Next-Generation Optoelectronics

Author: BenchChem Technical Support Team. **Date:** February 2026

Compound of Interest

Compound Name: 3,6-Di(pyridin-4-yl)-9H-carbazole

Cat. No.: B8244154

[Get Quote](#)

Executive Summary: The 3,6-Regioisomer Advantage

In the molecular engineering of organic semiconductors, the carbazole nucleus is ubiquitous. However, the choice of substitution position dictates functionality. While 2,7-substitution extends conjugation length (ideal for high-mobility polymers), 3,6-substitution offers a distinct electronic advantage: Triplet Energy Confinement.

By linking substituents at the 3,6-positions (para to the nitrogen), we induce a unique electronic decoupling. The nitrogen atom's lone pair participates in the

-system, but the 3,6-linkage creates a twisted biphenyl-like geometry that limits conjugation length compared to the 2,7-isomer. This structural feature results in:

- High Triplet Energy (): Crucial for host materials in Phosphorescent and Thermally Activated Delayed Fluorescence (TADF) OLEDs to prevent reverse energy transfer.
- Electrochemical Stability: The 3 and 6 positions are the most reactive sites for oxidative coupling; blocking them enhances the oxidative stability of the Hole Transport Material (HTM).

- **Synthetic Accessibility:** Direct bromination of carbazole selectively targets the 3,6-positions, making these derivatives cost-effective for large-scale production (e.g., Perovskite Solar Cells).

Strategic Synthesis: From Monomer to Functional Material

The synthesis of 3,6-derivatives relies on the high reactivity of the positions para to the nitrogen. The following workflow ensures high regioselectivity and yield.

Critical Intermediate: 3,6-Dibromocarbazole

The quality of the final optoelectronic material depends entirely on the purity of the 3,6-dibromo intermediate. Traces of 3-monobromo or 1,3,6-tribromo impurities will act as trap states in the final device.

Experimental Protocol: Regioselective Bromination

- **Objective:** Synthesize >99% pure 3,6-dibromo-9-(2-ethylhexyl)carbazole.
- **Rationale:** N-alkylation is performed before or after bromination depending on solubility needs. Here, we describe the direct bromination of the N-alkylated species to maintain solubility.

Reagents:

- 9-(2-ethylhexyl)carbazole (1.0 eq)
- N-Bromosuccinimide (NBS) (2.05 eq) – Note: Use a slight excess, but avoid >2.1 eq to prevent tribromination.
- Dimethylformamide (DMF) (anhydrous)

Step-by-Step Methodology:

- **Dissolution:** Dissolve 9-(2-ethylhexyl)carbazole in DMF (0.1 M concentration) in a round-bottom flask shielded from light (aluminum foil).

- Cooling: Cool the solution to 0°C in an ice bath. Causality: Low temperature suppresses the kinetic formation of thermodynamically stable impurities.
- Addition: Add NBS portion-wise over 30 minutes. Do not dump all at once; exothermic spikes can ruin regioselectivity.
- Reaction: Allow to warm to Room Temperature (RT) and stir for 12 hours. Monitor via TLC (Hexane:DCM 9:1).
- Quench & Workup: Pour into ice water. Filter the white precipitate.
- Purification (Critical): Recrystallize from Ethanol/Toluene (3:1). Note: Column chromatography is often insufficient to remove trace isomers; recrystallization is mandatory for electronic-grade purity.

Modular Functionalization Workflow

Once the dibromo-scaffold is secured, Suzuki-Miyaura or Buchwald-Hartwig couplings introduce the optoelectronic functionality.



[Click to download full resolution via product page](#)

Figure 1: Synthetic pathway emphasizing the critical intermediate stage. The modular design allows for tuning the HOMO/LUMO levels via the coupling partner.

Material Characterization: Validating Electronic Structure

Trustworthy data is the bedrock of device engineering. For 3,6-carbazole derivatives, determining the HOMO level is critical for aligning with the anode (OLED) or perovskite valence band (PSC).

Protocol: Cyclic Voltammetry (CV) for HOMO/LUMO

Objective: Determine the ionization potential (

) and electron affinity (

).

Setup:

- Working Electrode: Glassy Carbon (polished to mirror finish with 0.05 μm alumina).
- Counter Electrode: Platinum Wire.[\[1\]](#)
- Reference Electrode: Ag/Ag⁺ (0.01 M AgNO₃ in Acetonitrile). Note: Using aqueous Ag/AgCl is erroneous for organic solvents due to junction potentials.
- Electrolyte: 0.1 M Tetrabutylammonium Hexafluorophosphate () in dry Dichloromethane (DCM).
- Internal Standard: Ferrocene ().

Procedure:

- Blank Scan: Run a CV of the electrolyte alone to ensure no background impurities.

- Sample Scan: Dissolve the carbazole derivative (1 mM). Deoxygenate with Argon for 10 mins.
- Measurement: Scan at 100 mV/s. Observe the oxidation onset ().^{[2][3]}
- Calibration: Add Ferrocene. Measure the of the couple.

Calculation (Self-Validating Logic): Do not use generic constants. Calibrate against vacuum level using the Ferrocene standard (4.8 eV or 5.1 eV below vacuum).

Note: 3,6-substituted carbazoles typically show reversible oxidation due to the protection of reactive sites.

Applications & Performance Data

OLED Host Materials

In OLEDs, particularly for blue emitters, the host must have a higher triplet energy than the emitter to confine excitons. 3,6-Carbazole derivatives (e.g., mCBP) are industry standards because the meta-linkage (relative to the carbazole nitrogen's conjugation axis) disrupts extended conjugation, keeping

high (eV).

Perovskite Solar Cells (PSCs)

As Hole Transport Materials (HTMs), 3,6-derivatives like X51 or V1209 provide a cost-effective alternative to Spiro-OMeTAD. The 3,6-substitution provides enough steric bulk to prevent excessive crystallization (which ruins film formation) while maintaining sufficient hole mobility (

to).

Comparative Data Table

Material	Core Structure	Subst.[4] [5][6][7] [8] Position	HOMO (eV)	T1 Energy (eV)	Application	Key Advantage
mCBP	Bis-Carbazole	3,6 (meta-linked)	-6.0	2.90	OLED Host	High T1, suitable for Blue Phosphorescence
X51	Spiro-Carbazole	3,6-substituted	-5.1	-	PSC HTM	High solubility, cost-effective synthesis
Cz-TPA	Carbazole-TPA	2,7-substituted	-5.3	2.65	OLED/OPV	Higher mobility, but lower T1 (Green/Red Host)
2PACz	Carbazole-Phosphonic	N-substituted	-5.6	-	PSC SAM	Self-Assembled Monolayer for interface passivation

Design Logic & Mechanism

The following diagram illustrates the charge transfer mechanism in a Perovskite Solar Cell utilizing a 3,6-carbazole HTM. The critical factor is the energy alignment: The HTM HOMO must be slightly above the Perovskite Valence Band Maximum (VBM) to facilitate hole extraction while blocking electrons.

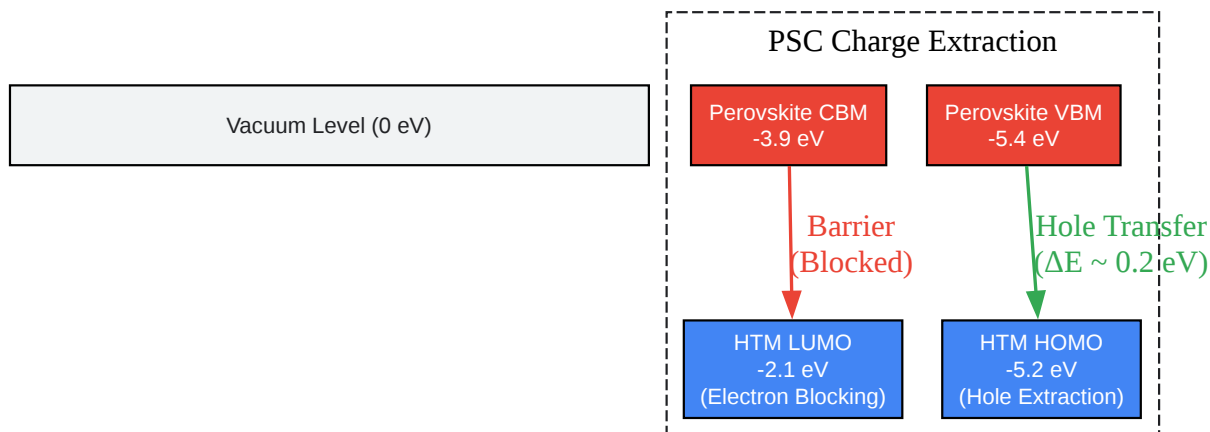

[Click to download full resolution via product page](#)

Figure 2: Energy level alignment diagram. The 3,6-carbazole derivative (Blue) is engineered to align its HOMO with the Perovskite VBM (Red), ensuring efficient hole extraction while its high LUMO blocks electron recombination.

References

- Albrecht, K. et al. "Carbazole-Based Hole-Transport Materials for Perovskite Solar Cells." *Journal of Materials Chemistry A*, 2023.
- BenchChem Protocols. "Application Notes and Protocols for the Synthesis of Conductive Polymers from 3,6-Dibromocarbazole Monomers." BenchChem, 2025.[1][9]
- Kido, J. et al. "3,6-Carbazole vs 2,7-Carbazole: A comparative study of hole-transporting polymeric materials." *Beilstein Journal of Organic Chemistry*, 2016.
- Adachi, C. et al. "Phenylpyridine and carbazole based host materials for highly efficient blue TADF OLEDs." *ResearchGate*, 2025.
- RSC Reviews. "Two decades of carbazole-triarylborane hybrids in optoelectronics." *Materials Chemistry Frontiers*, 2025.[10]

Need Custom Synthesis?

BenchChem offers custom synthesis for rare earth carbides and specific isotopic labeling.

Email: info@benchchem.com or [Request Quote Online](#).

Sources

- [1. pdf.benchchem.com](https://pdf.benchchem.com) [pdf.benchchem.com]
- [2. 3,6-Carbazole vs 2,7-carbazole: A comparative study of hole-transporting polymeric materials for inorganic–organic hybrid perovskite solar cells - PMC](#) [pmc.ncbi.nlm.nih.gov]
- [3. beilstein-journals.org](https://beilstein-journals.org) [beilstein-journals.org]
- [4. researchgate.net](https://researchgate.net) [researchgate.net]
- [5. pdf.benchchem.com](https://pdf.benchchem.com) [pdf.benchchem.com]
- [6. researchgate.net](https://researchgate.net) [researchgate.net]
- [7. researchgate.net](https://researchgate.net) [researchgate.net]
- [8. pubs.acs.org](https://pubs.acs.org) [pubs.acs.org]
- [9. pdf.benchchem.com](https://pdf.benchchem.com) [pdf.benchchem.com]
- [10. Two decades of carbazole–triarylborane hybrids in optoelectronics - Materials Chemistry Frontiers \(RSC Publishing\)](#) [pubs.rsc.org]
- To cite this document: BenchChem. [Advanced Architectures of 3,6-Substituted Carbazole Derivatives for Next-Generation Optoelectronics]. BenchChem, [2026]. [Online PDF]. Available at: [<https://www.benchchem.com/product/b8244154#literature-review-of-3-6-substituted-carbazole-derivatives-for-optoelectronics>]

Disclaimer & Data Validity:

The information provided in this document is for Research Use Only (RUO) and is strictly not intended for diagnostic or therapeutic procedures. While BenchChem strives to provide accurate protocols, we make no warranties, express or implied, regarding the fitness of this product for every specific experimental setup.

Technical Support: The protocols provided are for reference purposes. Unsure if this reagent suits your experiment? [[Contact our Ph.D. Support Team for a compatibility check](#)]

Need Industrial/Bulk Grade? [Request Custom Synthesis Quote](#)

BenchChem

Our mission is to be the trusted global source of essential and advanced chemicals, empowering scientists and researchers to drive progress in science and industry.

Contact

Address: 3281 E Guasti Rd

Ontario, CA 91761, United States

Phone: (601) 213-4426

Email: info@benchchem.com