

Application Note: Device Architecture & Protocols for Isoindigo-Based Organic Photovoltaics

Author: BenchChem Technical Support Team. **Date:** April 2026

Compound of Interest

Compound Name: 4,7-Dibromo-2-(2-ethylhexyl)isoindoline-1,3-dione

Cat. No.: B8242813

[Get Quote](#)

Executive Summary & Scientific Rationale

This application note details the fabrication, optimization, and characterization of Organic Photovoltaics (OPVs) utilizing Isoindigo (IID) derivatives. While "isoindoline" refers to the core bicyclic heteroaromatic system, its most potent application in OPVs is through the Isoindigo dye structure—a centrosymmetric bis-isoindoline derivative.

Why Isoindigo?

- **Electronic Structure:** Isoindigo is a strong electron-deficient (acceptor) unit. When copolymerized with electron-rich units (e.g., thiophene), it creates Donor-Acceptor (D-A) polymers with deep HOMO levels (to eV), leading to high Open Circuit Voltage ().

- Planarity & Crystallinity: The lactam rings induce strong
-
stacking. While this improves charge mobility, it creates solubility and aggregation challenges that this protocol specifically addresses through additive engineering.
- Stability: The inverted architecture proposed here utilizes metal-oxide transport layers (ZnO, MoO

) to maximize the intrinsic oxidative stability of the isoindigo core.

Device Architecture: The Inverted Configuration[1] [2][3][4]

We utilize an Inverted Architecture (Cathode bottom / Anode top). Unlike the conventional structure, this setup eliminates the unstable PEDOT:PSS interface and the air-sensitive low-work-function cathode (e.g., Calcium/Aluminum), significantly enhancing device lifetime.

Layer Stack Visualization

The following diagram illustrates the precise stack and energy alignment logic.

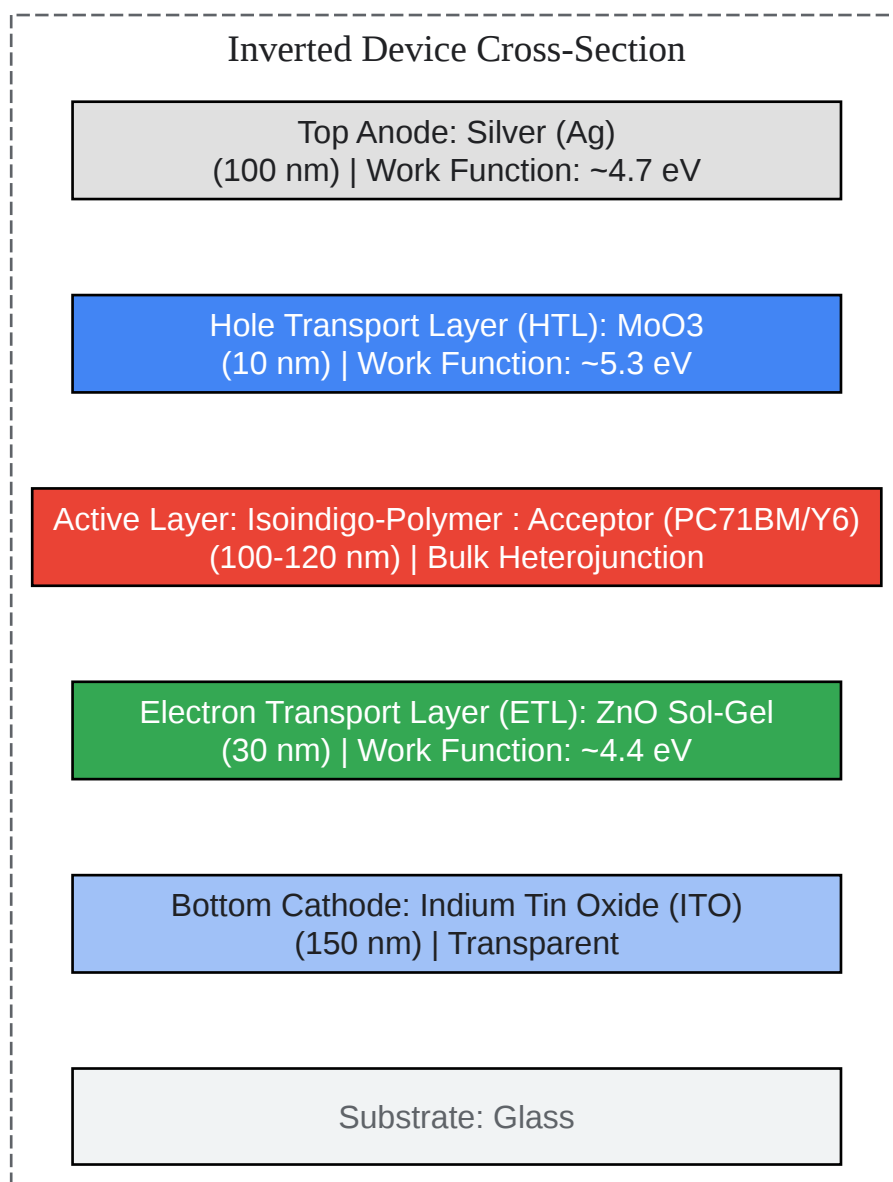

[Click to download full resolution via product page](#)

Caption: Figure 1. Inverted OPV stack designed for Isoindigo polymers. The ZnO/MoO₃ interlayers ensure selective charge extraction and protect the active layer from ambient degradation.

Critical Protocol: Active Layer Formulation (The "Ink")

The solubility of isoindigo polymers is the primary bottleneck. They tend to aggregate in solution, leading to large domains in the film that kill exciton dissociation.

Materials:

- Donor: Poly(isoindigo-alt-thiophene) derivative (e.g., P(IID-T) or PffIDA).
- Acceptor: PC
BM (Fullerene) or Y6 (Non-Fullerene).
- Solvents: o-Dichlorobenzene (o-DCB) or Chlorobenzene (CB).
- Additive: 1,8-Diiodooctane (DIO) or 1-Chloronaphthalene (CN).[\[1\]](#)

Protocol:

- Ratio: Weigh Donor:Acceptor in a 1:1.5 (weight ratio).
 - Note: Isoindigo polymers often require higher acceptor loading than P3HT.
- Concentration: Dissolve to a total concentration of 20 mg/mL in o-DCB.
- Additive Spiking (Crucial): Add 2.5% (v/v) DIO.
 - Mechanism:[\[2\]](#)[\[1\]](#)[\[3\]](#)[\[4\]](#) DIO selectively dissolves the fullerene/NFA and has a high boiling point. It remains in the film longer than the host solvent, preventing the isoindigo polymer from crystallizing too quickly and forming oversized domains [\[1\]](#).
- Heating: Stir at 100°C for at least 6 hours inside a glovebox (N atmosphere).
 - Self-Validation Check: The solution must be homogenous and free of gel particles. If gelation occurs, switch solvent to Chloroform (CF) and lower temperature to 50°C.

Fabrication Workflow: Step-by-Step

This protocol assumes the use of an N

-filled glovebox for all steps post-ZnO annealing.

Substrate Preparation

- Etching: Pattern ITO glass (15 /sq) using acid etching or purchase pre-patterned.
- Cleaning: Ultrasonic bath sequence (15 min each):
 - Detergent water (Alconox)
 - Deionized Water
 - Acetone
 - Isopropanol (IPA).
- Activation: UV-Ozone treat for 20 mins to increase ITO work function and wettability.

Electron Transport Layer (ZnO)[4]

- Precursor: Dissolve Zinc Acetate Dihydrate (100 mg) in 2-Methoxyethanol (1 mL) + Ethanolamine (28 L). Stir overnight.
- Deposition: Spin-coat at 4000 rpm for 30s in air.
- Annealing: Bake at 200°C for 30 mins in air.
 - Causality: High temperature is required to convert the precursor to crystalline ZnO. Incomplete conversion leads to "S-shaped" J-V curves due to charge extraction barriers [2].

Active Layer Deposition[4]

- Transfer: Move substrates to N glovebox.

- Spin Coating: Deposit the hot (100°C) active layer ink at 800-1200 rpm (60s). Target thickness: 100 nm.
 - Optimization: If the film looks "cloudy" (excessive aggregation), increase spin speed or increase substrate temperature during coating.
- Solvent Annealing (Optional): If using DIO, place films in a covered petri dish for 20 mins to slow-dry.
- Vacuum Drying: Place films in the evaporator antechamber (vacuum) for 30 mins to remove trace DIO.

Top Electrode (Hole Contact)

- HTL: Thermally evaporate 10 nm of MoO

at

under high vacuum (

Torr).

- Anode: Thermally evaporate 100 nm of Ag at

.

- Masking: Ensure the overlap area (pixel size) is calibrated (typically 0.04 cm

).

Workflow Logic Diagram

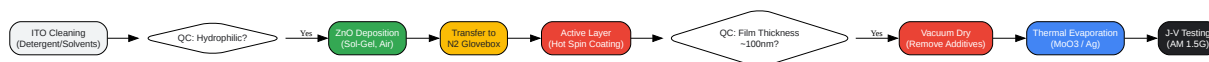

[Click to download full resolution via product page](#)

Caption: Figure 2. Fabrication workflow with integrated Quality Control (QC) checkpoints to ensure batch consistency.

Characterization & Self-Validation

To ensure scientific integrity, the following data must be collected.

Current-Voltage (J-V) Analysis

- Standard: AM 1.5G spectrum (100 mW/cm²).^[5]
- Metric Targets (Isoindigo/PC71BM):
 - V_{oc} : > 0.85 V (Due to deep HOMO of Isoindigo).
 - J_{sc} : > 12 mA/cm²
 - FF : > 60%.^[5]
- Troubleshooting:
 - Low FF (<50%): Usually indicates poor morphology. Increase DIO concentration.
 - S-Shape Curve: Indicates a barrier at the ZnO interface. Re-clean ITO or increase ZnO annealing temp.

Morphology Check (AFM)

- Protocol: Tapping mode AFM on the active layer.
- Target: A fine phase separation with RMS roughness of 2-5 nm.
- Warning Sign: Large crystallites (>50 nm) indicate excessive aggregation of the isoindigo polymer.

Space Charge Limited Current (SCLC)

- Purpose: To measure hole () and electron () mobilities.
- Device: Fabricate "hole-only" devices (ITO/PEDOT/Active/MoO₃/Ag) to isolate hole transport.
- Analysis: Fit the dark current J-V curve to the Mott-Gurney law. Isoindigo polymers typically show high hole mobilities (cm /Vs) due to their planarity [3].

References

- Stalder, R. et al. (2010). "Isoindigo: A Versatile Electron-Deficient Unit For High-Performance Organic Electronics." [6] Chemistry of Materials. [[Link](#)]
- Hau, S. K. et al. (2010). "Air-stable inverted flexible polymer solar cells using zinc oxide nanoparticles as an electron selective layer." Applied Physics Letters. [[Link](#)]
- Geng, H. et al. (2019). "Recent Advances in Isoindigo-Based Organic Thermoelectrics and Photovoltaics." Advanced Energy Materials. [[Link](#)]
- Liang, Y. et al. (2010). "For the Bright Future—Bulk Heterojunction Polymer Solar Cells with Power Conversion Efficiency of 7.4%." Advanced Materials. [[Link](#)]

Need Custom Synthesis?

BenchChem offers custom synthesis for rare earth carbides and specific isotopic labeling.

Email: info@benchchem.com or [Request Quote Online](#).

Sources

- 1. [researchgate.net](https://www.researchgate.net) [[researchgate.net](https://www.researchgate.net)]

- [2. researchgate.net \[researchgate.net\]](https://www.researchgate.net)
- [3. d-nb.info \[d-nb.info\]](https://www.d-nb.info)
- [4. lab.semi.ac.cn \[lab.semi.ac.cn\]](https://www.lab.semi.ac.cn)
- [5. Solution-Processed Organic Photovoltaics Based on Indoline Dye Molecules Developed in Dye-Sensitized Solar Cells - PMC \[pmc.ncbi.nlm.nih.gov\]](https://pubmed.ncbi.nlm.nih.gov/31111111/)
- [6. Recent Advances in Isoindigo-Inspired Organic Semiconductors - PubMed \[pubmed.ncbi.nlm.nih.gov\]](https://pubmed.ncbi.nlm.nih.gov/31111111/)
- To cite this document: BenchChem. [Application Note: Device Architecture & Protocols for Isoindigo-Based Organic Photovoltaics]. BenchChem, [2026]. [Online PDF]. Available at: [\[https://www.benchchem.com/product/b8242813/docs#application-note-device-architecture-protocols-for-isoindigo-based-organic-photovoltaics\]](https://www.benchchem.com/product/b8242813/docs#application-note-device-architecture-protocols-for-isoindigo-based-organic-photovoltaics)

Disclaimer & Data Validity:

The information provided in this document is for Research Use Only (RUO) and is strictly not intended for diagnostic or therapeutic procedures. While BenchChem strives to provide accurate protocols, we make no warranties, express or implied, regarding the fitness of this product for every specific experimental setup.

Technical Support: The protocols provided are for reference purposes. Unsure if this reagent suits your experiment?

Need Industrial/Bulk Grade? [Request Custom Synthesis Quote](#)

BenchChem

Our mission is to be the trusted global source of essential and advanced chemicals, empowering scientists and researchers to drive progress in science and industry.

Contact

Address: 3281 E Guasti Rd
Ontario, CA 91761, United States
Phone: (601) 213-4426
Email: info@benchchem.com

Contact our Ph.D. Support Team for a compatibility check