

Application Note: Quantitative Analysis of Endrin Aldehyde using Mass Spectrometry

Author: BenchChem Technical Support Team. **Date:** April 2026

Compound of Interest

Compound Name: *Endrin aldehyde*

CAS No.: 77287-19-5

Cat. No.: B8236067

[Get Quote](#)

Introduction

Endrin aldehyde, a degradation product and impurity of the organochlorine pesticide endrin, is a persistent and toxic environmental contaminant.[1] Its presence in various matrices such as water, soil, and food products necessitates sensitive and specific analytical methods for accurate quantification to ensure environmental and public health.[2] This application note provides a comprehensive protocol for the quantitative analysis of **Endrin aldehyde** using Gas Chromatography coupled with Mass Spectrometry (GC-MS), a robust and widely accepted technique for this purpose.[2] The methodologies described herein are grounded in established principles and validated against internationally recognized standards to ensure data integrity and reliability.[3]

The core of this analytical approach lies in the separation of **Endrin aldehyde** from complex sample matrices using gas chromatography, followed by its selective detection and quantification by a mass spectrometer. The inherent selectivity of mass spectrometry, particularly in tandem with chromatographic separation, provides a high degree of confidence in the identification and measurement of the target analyte, even at trace levels.[2] This

document will detail the necessary materials, step-by-step procedures for sample preparation and instrumental analysis, and guidelines for data interpretation and quality control.

Materials and Reagents

Chemicals and Standards

- **Endrin aldehyde** analytical standard ($\geq 98\%$ purity)
- Hexane (Pesticide residue grade)
- Acetone (Pesticide residue grade)
- Dichloromethane (Pesticide residue grade)
- Sodium sulfate, anhydrous (ACS grade, baked at 400°C for 4 hours)
- Florisil® (Pesticide residue grade, activated)[4]
- Helium (99.999% purity)
- Internal Standard (e.g., 1-bromo-2-nitrobenzene or pentachloronitrobenzene)

Glassware and Equipment

- Gas Chromatograph with Mass Spectrometer (GC-MS)
- Autosampler
- Capillary GC column (e.g., 5% phenyl-methylpolysiloxane)[2]
- Solid Phase Extraction (SPE) cartridges (e.g., C18)[2]
- SPE manifold
- Nitrogen evaporator
- Vortex mixer
- Centrifuge

- Analytical balance
- Micropipettes
- Glass vials with PTFE-lined caps
- Standard laboratory glassware (beakers, flasks, graduated cylinders)

Experimental Protocols

Sample Preparation: Solid Phase Extraction (SPE)

Effective sample preparation is crucial for removing interfering matrix components and concentrating the analyte of interest.[2] Solid Phase Extraction (SPE) is a widely used technique for the extraction of organochlorine pesticides from aqueous matrices.[2][5]

Protocol:

- **Sample Pre-treatment:** For aqueous samples, acidify 1 L of the sample to a pH below 2 using 6N HCl.[5] For solid samples, a suitable extraction method such as Soxhlet or ultrasonic extraction with a hexane/acetone mixture should be employed first.[6]
- **SPE Cartridge Conditioning:** Condition a C18 SPE cartridge by sequentially passing 10 mL of dichloromethane, 10 mL of acetone, and 10 mL of deionized water.[2]
- **Sample Loading:** Pass the pre-treated sample through the conditioned SPE cartridge at a flow rate of approximately 10 mL/min.[2]
- **Cartridge Drying:** After the entire sample has passed through, dry the cartridge by passing a stream of nitrogen gas through it for 10-15 minutes.[2]
- **Elution:** Elute the trapped analytes with 10 mL of dichloromethane.[2]
- **Drying and Concentration:** Pass the eluate through a column containing anhydrous sodium sulfate to remove any residual water. Concentrate the extract to a final volume of 1 mL under a gentle stream of nitrogen.[2]

- Solvent Exchange: If necessary, exchange the solvent to hexane for compatibility with the GC injection system.[2]
- Internal Standard Addition: Spike the final extract with a known concentration of an internal standard to correct for variations in injection volume and instrument response.

GC-MS Instrumentation and Analysis

The analysis is performed using a Gas Chromatograph coupled to a Mass Spectrometer. The GC separates the components of the sample extract, and the MS provides detection and quantification.

Workflow Diagram:



[Click to download full resolution via product page](#)

Caption: Workflow for **Endrin Aldehyde** analysis.

Instrumental Parameters:

A summary of typical GC-MS parameters is provided in the table below. These parameters should be optimized for the specific instrument and column used.

Parameter	Setting	Rationale
Gas Chromatograph		
Injection Mode	Splitless	To maximize the transfer of analyte onto the column for trace analysis.[7]
Inlet Temperature	250 °C	Ensures rapid volatilization of the analyte without thermal degradation.[8]
Carrier Gas	Helium	Provides good chromatographic efficiency and is inert.[9]
Flow Rate	1.0 mL/min (Constant Flow)	Optimal for most capillary columns, ensuring good separation.[10]
Oven Program	Initial 100°C (hold 1 min), ramp to 270°C at 10°C/min, hold 5 min	Provides good separation of Endrin aldehyde from other potential contaminants.[10]
Mass Spectrometer		
Ionization Mode	Electron Ionization (EI)	A robust and widely used technique that produces reproducible fragmentation patterns.[9]
Ion Source Temperature	230 °C	Balances ionization efficiency with minimizing thermal degradation.[9]
Electron Energy	70 eV	Standard energy for EI, leading to consistent and well-characterized fragmentation.[9]
Acquisition Mode	Selected Ion Monitoring (SIM)	Increases sensitivity and selectivity by monitoring only

specific ions characteristic of Endrin aldehyde.[11]

Monitored Ions (m/z)	To be determined from the mass spectrum of a standard. Typically, a quantifier and one or two qualifier ions are selected.	Based on the fragmentation pattern of Endrin aldehyde.
----------------------	--	--

Method Validation and Quality Control

To ensure the reliability of the results, the analytical method must be validated.[12] Key validation parameters include linearity, limit of detection (LOD), limit of quantification (LOQ), accuracy, and precision.[13][14]

- **Linearity:** A calibration curve should be generated using a series of standards of known concentrations. A linear regression analysis should yield a correlation coefficient (r^2) of >0.99 . [15]
- **LOD and LOQ:** The LOD is the lowest concentration of analyte that can be reliably detected, while the LOQ is the lowest concentration that can be accurately quantified. These are typically determined by analyzing replicate low-level standards.[10][15]
- **Accuracy and Precision:** Accuracy is determined by analyzing spiked samples at different concentration levels, with recoveries ideally falling within 70-120%. Precision is assessed by the relative standard deviation (RSD) of replicate measurements, which should typically be $<15\%$.[9]
- **Quality Control:** Each analytical batch should include a method blank, a laboratory control sample (LCS), and a matrix spike/matrix spike duplicate (MS/MSD) to monitor for contamination, instrument performance, and matrix effects.[3]

Data Analysis and Quantification Identification

The identification of **Endrin aldehyde** is based on two criteria:

- Retention Time: The retention time of the peak in the sample chromatogram must match that of the analytical standard within a predefined window.
- Ion Ratios: The relative abundance of the qualifier ions to the quantifier ion in the sample must match those of the standard within a specified tolerance.

Quantification

The concentration of **Endrin aldehyde** in the sample is determined using the calibration curve. The peak area of the quantifier ion is used for calculation. The use of an internal standard is highly recommended to correct for any variations during sample preparation and analysis.

Calculation:

$$\text{Concentration } (\mu\text{g/L or } \mu\text{g/kg}) = (\text{Area}_{\text{analyte}} / \text{Area}_{\text{IS}}) * (\text{Concentration}_{\text{IS}} / \text{Response}_{\text{Factor}}) * (\text{V}_{\text{extract}} / \text{M}_{\text{sample}})$$

Where:

- Area_analyte = Peak area of the **Endrin aldehyde** quantifier ion
- Area_IS = Peak area of the internal standard quantifier ion
- Concentration_IS = Concentration of the internal standard
- Response_Factor = Calculated from the calibration curve
- V_extract = Final volume of the sample extract
- M_sample = Mass or volume of the initial sample

Understanding the Fragmentation Pattern

In Electron Ionization Mass Spectrometry (EI-MS), the **Endrin aldehyde** molecule will fragment in a characteristic manner. Understanding this fragmentation is key to selecting the appropriate ions for SIM mode. Aldehydes typically undergo cleavage of the bonds adjacent to the carbonyl group.^{[16][17]} For **Endrin aldehyde**, with its complex polycyclic chlorinated structure, the fragmentation will be influenced by the stability of the resulting fragments.

Fragmentation Diagram:

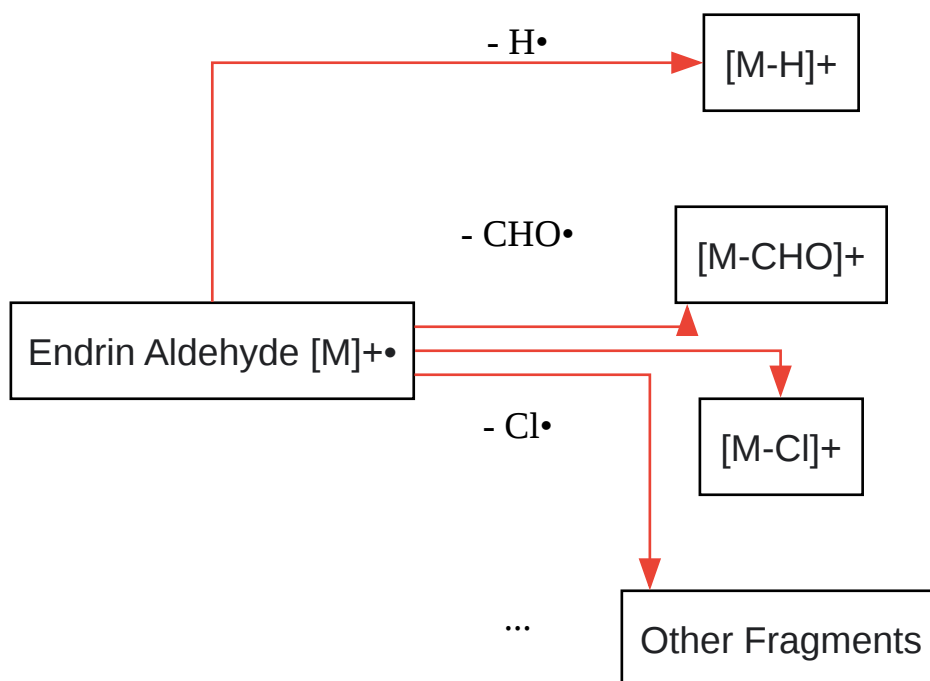

[Click to download full resolution via product page](#)

Caption: Potential fragmentation of **Endrin Aldehyde**.

The exact m/z values for the molecular ion and key fragments should be confirmed by running a full scan mass spectrum of a pure **Endrin aldehyde** standard. The most abundant and specific fragment ion is typically chosen as the quantifier, while other characteristic fragments serve as qualifiers.

Conclusion

This application note provides a detailed and robust protocol for the quantification of **Endrin aldehyde** using GC-MS. Adherence to the described procedures for sample preparation, instrumental analysis, and quality control will ensure the generation of accurate and defensible data. The principles and techniques outlined are applicable to a wide range of sample matrices and can be adapted as necessary with appropriate validation.

References

- Guidelines for in-house validation of analytical methods for pesticide residues in food and animal feeds. (n.d.). PubMed. Retrieved March 7, 2026, from [\[Link\]](#)
- Method 8081B: Organochlorine Pesticides by Gas Chromatography. (2007, February). In Test Methods for Evaluating Solid Waste, Physical/Chemical Methods. EPA. Retrieved March 7, 2026, from [\[Link\]](#)
- Method 608.3: Organochlorine Pesticides and PCBs by GC/HSD. (2016, December 1). EPA. Retrieved March 7, 2026, from [\[Link\]](#)
- Analysis of organochlorine pesticides and PCBs using EPA method 608.3. (n.d.). OI Analytical. Retrieved March 7, 2026, from [\[Link\]](#)
- Method validation and quality control procedures for pesticide residues analysis in food and feed. (2011, January 1). European Commission. Retrieved March 7, 2026, from [\[Link\]](#)
- Analysis of Organochlorine Pesticides in Waste Water Using EPA Method 608.3 with Semi-Automated Solid Phase Extraction (EZSpe®). (n.d.). FMS, Inc. Retrieved March 7, 2026, from [\[Link\]](#)
- Validation of an Analytical Method for the Determination of Pesticide Residues in Vine Leaves by GC-MS/MS. (2018, June 7). Journal of Agricultural and Food Chemistry. ACS Publications. Retrieved March 7, 2026, from [\[Link\]](#)
- Validation of a Multi-Residue Analysis Method for 287 Pesticides in Citrus Fruits Mandarin Orange and Grapefruit Using Liquid Chromatography–Tandem Mass Spectrometry. (2022, November 4). Foods. MDPI. Retrieved March 7, 2026, from [\[Link\]](#)
- **Endrin aldehyde**. (n.d.). PubChem. Retrieved March 7, 2026, from [\[Link\]](#)
- Test Methods for Evaluating Solid Waste, Physical/Chemical Methods, Method 8081B: Organochlorine Pesticides by Gas Chromatograph. (n.d.). NUCLEUS information resources. Retrieved March 7, 2026, from [\[Link\]](#)
- Analytical Method for aldrin, endrin and dieldrin. (n.d.). Ministry of Health, Labour and Welfare, Japan. Retrieved March 7, 2026, from [\[Link\]](#)

- Toxicological Profile for Endrin. (2020, May). Agency for Toxic Substances and Disease Registry. Retrieved March 7, 2026, from [\[Link\]](#)
- A Method for the Trace Analysis of 175 Pesticides Using the Agilent Triple Quadrupole GC/MS/MS. (2009, February 25). Agilent Technologies. Retrieved March 7, 2026, from [\[Link\]](#)
- Endrin and DDT Stability Study for Drinking Water Methods with an Agilent 8890 GC/5977B GC/MSD. (n.d.). Agilent Technologies. Retrieved March 7, 2026, from [\[Link\]](#)
- Methods of analysis by the U.S. Geological Survey National Water Quality Laboratory -- Determination of organochlorine pesticides. (n.d.). U.S. Geological Survey. Retrieved March 7, 2026, from [\[Link\]](#)
- Determination of Organochlorine Pesticides in Wildlife Liver and Serum Using Gas Chromatography Tandem Quadrupole Mass Spectrometry. (2015, August 30). Journal of Analytical & Bioanalytical Techniques. Longdom Publishing. Retrieved March 7, 2026, from [\[Link\]](#)
- Mass Spectrometry - Fragmentation Patterns. (2023, August 29). Chemistry LibreTexts. Retrieved March 7, 2026, from [\[Link\]](#)
- Mass Spectrometry - Examples. (n.d.). University of Arizona Department of Chemistry and Biochemistry. Retrieved March 7, 2026, from [\[Link\]](#)
- Fragmentation patterns in the mass spectra of organic compounds. (n.d.). Chemguide. Retrieved March 7, 2026, from [\[Link\]](#)
- Lec-28 || Mass fragmentation pattern of aldehydes. (2022, March 17). YouTube. Retrieved March 7, 2026, from [\[Link\]](#)

Need Custom Synthesis?

BenchChem offers custom synthesis for rare earth carbides and specific isotopic labeling.

Email: info@benchchem.com or [Request Quote Online](#).

Sources

- [1. atsdr.cdc.gov \[atsdr.cdc.gov\]](https://atsdr.cdc.gov)
- [2. pdf.benchchem.com \[pdf.benchchem.com\]](https://pdf.benchchem.com)
- [3. eurl-pesticides.eu \[eurl-pesticides.eu\]](https://eurl-pesticides.eu)
- [4. epa.gov \[epa.gov\]](https://epa.gov)
- [5. fms-inc.com \[fms-inc.com\]](https://fms-inc.com)
- [6. epa.gov \[epa.gov\]](https://epa.gov)
- [7. documents.thermofisher.com \[documents.thermofisher.com\]](https://documents.thermofisher.com)
- [8. agilent.com \[agilent.com\]](https://agilent.com)
- [9. longdom.org \[longdom.org\]](https://longdom.org)
- [10. analysis.rs \[analysis.rs\]](https://analysis.rs)
- [11. hpst.cz \[hpst.cz\]](https://hpst.cz)
- [12. Guidelines for in-house validation of analytical methods for pesticide residues in food and animal feeds - PubMed \[pubmed.ncbi.nlm.nih.gov\]](https://pubmed.ncbi.nlm.nih.gov)
- [13. documents.thermofisher.com \[documents.thermofisher.com\]](https://documents.thermofisher.com)
- [14. pubs.acs.org \[pubs.acs.org\]](https://pubs.acs.org)
- [15. mdpi.com \[mdpi.com\]](https://mdpi.com)
- [16. chem.libretexts.org \[chem.libretexts.org\]](https://chem.libretexts.org)
- [17. Mass Spectrometry - Examples | UArizona Department of Chemistry and Biochemistry \[cbc.arizona.edu\]](https://cbc.arizona.edu)
- To cite this document: BenchChem. [Application Note: Quantitative Analysis of Endrin Aldehyde using Mass Spectrometry]. BenchChem, [2026]. [Online PDF]. Available at: [<https://www.benchchem.com/product/b8236067/docs#application-note-quantitative-analysis-of-endrin-aldehyde-using-mass-spectrometry>]

Disclaimer & Data Validity:

The information provided in this document is for Research Use Only (RUO) and is strictly not intended for diagnostic or therapeutic procedures. While BenchChem strives to provide accurate protocols, we make no warranties, express or implied, regarding the fitness of this product for every specific experimental setup.

Technical Support: The protocols provided are for reference purposes. Unsure if this reagent suits your experiment?

Need Industrial/Bulk Grade? [Request Custom Synthesis Quote](#)

BenchChem

Our mission is to be the trusted global source of essential and advanced chemicals, empowering scientists and researchers to drive progress in science and industry.

Contact

Address: 3281 E Guasti Rd
Ontario, CA 91761, United States
Phone: (601) 213-4426
Email: info@benchchem.com

[Contact our Ph.D. Support Team for a compatibility check](#)