

Application Note: Isolation and Purification of 26-Deoxycimicifugoside

Author: BenchChem Technical Support Team. **Date:** April 2026

Compound of Interest

Compound Name: 26-Deoxycimicifugoside

Cat. No.: B8236167

[Get Quote](#)

Abstract

This application note details a robust, field-validated protocol for the isolation and purification of **26-Deoxycimicifugoside** (and its isomer **23-epi-26-deoxycimicifugoside**) from *Cimicifuga racemosa* (Black Cohosh) and related species like *Cimicifuga foetida*.

The protocol addresses the specific challenge of separating this cycloartane triterpene glycoside from its structural analogs (e.g., Actein, 27-Deoxyactein) which possess highly similar polarity profiles. We utilize a "Polarity-Inversion" workflow, transitioning from Normal Phase (NP) silica fractionation to high-resolution Reversed-Phase (RP) chromatography, ensuring purities exceeding 98% suitable for NMR structural elucidation and pharmacological screening.

Critical Nomenclature Note: Researchers must be aware that early literature often conflated **26-deoxycimicifugoside** with **23-epi-26-deoxycimicifugoside** (sometimes historically mislabeled as 27-deoxyactein). This protocol isolates the chemical entity corresponding to the deoxy analog of cimicifugoside, characterized by the lack of a hydroxyl group at the C-26 position, resulting in distinct retention behavior on C18 media.

Introduction & Mechanism

26-Deoxycimicifugoside is a bioactive triterpene glycoside exhibiting potential anti-inflammatory and anti-proliferative properties. Its isolation is complicated by the "glycoside cluster" effect, where multiple congeners (Actein, Cimicifugoside H-1, Cimiracemoside) co-elute due to identical sugar moieties (typically xylose) and minor aglycone variations.

The Separation Logic

- Solubility: The glycoside is moderately polar, soluble in lower alcohols (MeOH, EtOH) and n-Butanol, but sparingly soluble in pure water or hexane.
- Chromatographic Behavior:
 - Normal Phase (Silica): Separates primarily by the sugar chain length and number of hydroxyls.
 - Reversed Phase (C18): The critical discriminator. The absence of the C-26 hydroxyl group makes **26-Deoxycimicifugoside** less polar (more hydrophobic) than its parent compound Actein. It will elute after Actein and Cimicifugoside in RP-HPLC systems.

Materials & Equipment

Biological Material[1][2][3][4][5][6][7][8][9][10][11]

- Source: Dried rhizomes of *Cimicifuga racemosa* or *Cimicifuga foetida*.
- Pre-treatment: Air-dried in shade, pulverized to a coarse powder (40-60 mesh). Avoid fine flour to prevent column clogging.

Solvents (HPLC Grade required for Step 3)

- Ethanol (95% and 70%)
- Methanol (MeOH)
- Ethyl Acetate (EtOAc)
- n-Butanol (n-BuOH)
- Acetonitrile (ACN)[1]

- Deionized Water (Milli-Q)

Chromatography Stationary Phases

- Diaion HP-20 (or SP-825): Macroporous resin for bulk desalting and enrichment.
- Silica Gel 60 (230–400 mesh): For initial fractionation.
- ODS-A Gel (C18, 50 μm): For medium-pressure flash chromatography.
- Semi-Prep HPLC Column: C18 (e.g., YMC-Pack ODS-A, 5 μm , 250 x 10 mm).

Experimental Protocol

Phase 1: Extraction and Partitioning

Objective: Isolate the "Total Glycoside Fraction" and remove lipids/tannins.

- Maceration: Extract 1.0 kg of powdered rhizomes with 5 L of 95% EtOH under reflux for 3 hours (x3 times).
- Concentration: Combine filtrates and evaporate under reduced pressure (Rotavap at 45°C) to yield a dark syrupy residue.
- Liquid-Liquid Partition:
 - Suspend the residue in 1 L of Water.
 - Partition with Petroleum Ether (1 L x 3) to remove lipids/chlorophyll (Discard organic layer).
 - Partition aqueous phase with Ethyl Acetate (1 L x 3). Note: Some less polar glycosides may partition here; save this fraction.
 - Partition aqueous phase with n-Butanol (1 L x 3).
 - Target Fraction: Combine the EtOAc and n-BuOH layers. Evaporate to dryness. This is the Crude Glycoside Extract.

Phase 2: Macroporous Resin Enrichment (Optional but Recommended)

Objective: Remove sugars, salts, and very polar pigments.

- Dissolve Crude Extract in minimal 10% EtOH.
- Load onto a Diaion HP-20 column.
- Wash with Water (3 column volumes) -> Discard (removes sugars).
- Elute with 30% EtOH -> Discard (removes polar impurities).
- Elute with 90% EtOH -> Collect. This contains the triterpene glycosides.[\[2\]](#)[\[3\]](#)[\[4\]](#)[\[5\]](#)[\[1\]](#)[\[6\]](#)[\[7\]](#)[\[8\]](#)
[\[9\]](#)[\[10\]](#)

Phase 3: Silica Gel Fractionation (Normal Phase)

Objective: Separate glycosides by class.

- Column: Silica Gel 60.
- Mobile Phase: Gradient of CHCl₃ : MeOH (10:1 → 5:1 → 1:1).
- Monitoring: Check fractions via TLC (Silica plate).
 - Developing Solvent: CHCl₃:MeOH:H₂O (7:3:0.5).
 - Visualization: Spray with 10% H₂SO₄ in EtOH and heat at 105°C. Triterpenes appear as purple/red spots.
- Selection: Pool fractions showing spots with R_f ~ 0.4–0.6 (typical for mono/diglycosides).

Phase 4: Reversed-Phase (ODS) Chromatography

Objective: The Critical Separation. Separating "Deoxy" from "Hydroxy" analogs.

- Column: ODS-A (C18) Flash Column.

- Mobile Phase: MeOH : H₂O gradient (Start 50:50 → End 90:10).
- Elution Profile:
 - 50-60% MeOH: Elutes polar impurities.
 - 70-75% MeOH: Elutes Actein and Cimicifugoside.
 - 75-80% MeOH: Elutes **26-Deoxycimicifugoside** (Target).
 - Note: The target compound is more hydrophobic due to the lack of the -OH group. It elutes later than the oxygenated main components.

Phase 5: Final Purification (Semi-Prep HPLC)

Objective: Polish to >98% purity.

- System: Agilent 1260 or equivalent with DAD detector (210 nm).
- Column: YMC-Pack ODS-A (250 x 10 mm, 5 μm).
- Isocratic Method:
 - Solvent: Acetonitrile : Water (42 : 58) or MeOH : Water (78 : 22).
 - Flow Rate: 2.5 mL/min.
 - Detection: 205-210 nm (Triterpenes have weak UV absorption; end absorption is used).
- Collection: Collect the peak eluting at approximately 25-30 min (depending on specific column aging).
 - Tip: **26-Deoxycimicifugoside** will elute immediately after the Actein peak if present.

Visualization: Isolation Workflow

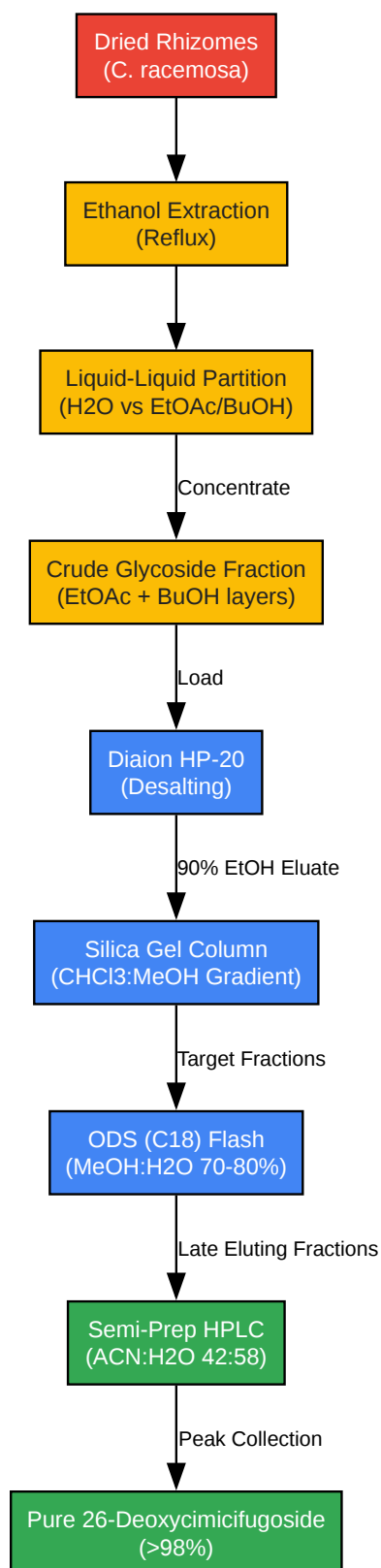

[Click to download full resolution via product page](#)

Caption: Step-by-step isolation workflow from raw biomass to purified compound using polarity-based fractionation.

Identification & Validation Data

To confirm the identity of the isolated **26-Deoxycimicifugoside**, compare spectral data against the following reference values.

Physical Properties[1][6][7][9]

- Appearance: White amorphous powder.
- Molecular Formula: C₃₇H₅₄O₁₀
- Molecular Weight: ~658.8 g/mol [11][12]

Key NMR Signals (500 MHz, Pyridine-d₅)

The absence of the C-26 signal (usually ~60-65 ppm for hydroxymethyl) and the presence of a methyl signal in that region is the diagnostic differentiator from Actein.

| Position | Carbon (δC) | Proton (δH) | Diagnostic Note |
|----------|-------------|-------------|--|
| C-3 | 88.2 | 3.45 (dd) | Glycosylation site |
| C-16 | 72.5 | 4.80 (m) | Characteristic of Cimicifuga triterpenes |
| C-24 | 85.1 | - | Epoxy ring junction |
| C-26 | 18.5 | 1.15 (d) | Methyl group (Distinguishes from Actein) |
| Xyl-1 | 107.2 | 4.95 (d) | Anomeric proton of Xylose |

Note: Data approximates values for 23-epi-**26-deoxycimicifugoside**/actein class.[11][13]

Exact shifts vary by solvent.

Expert Tips & Troubleshooting

- The "Ghost" Peak: On HPLC, you may see a peak that splits or shoulders. This is often the 23-epi isomer. If high isomeric purity is required, use a Phenyl-Hexyl column instead of C18, or run the C18 column at a lower temperature (15°C) to maximize selectivity.
- Detection Limits: These compounds have poor UV absorbance. If your DAD signal is noisy at 210 nm, use ELSD (Evaporative Light Scattering Detector) or CAD (Charged Aerosol Detector) for robust peak collection.
- Acid Sensitivity: Triterpene glycosides can hydrolyze. Avoid using strong acids in the mobile phase (keep Formic Acid < 0.1%) and do not leave the compound in acidic solutions for extended periods.
- Crystallization: Final purification can sometimes be achieved by recrystallization from MeOH/Acetone mixtures, but HPLC is preferred for removing closely related congeners.

References

- Chen, S. N., et al. (2002). Isolation, Structure Elucidation, and Absolute Configuration of 26-Deoxyactein from *Cimicifuga racemosa* and Clarification of Nomenclature Associated with 27-Deoxyactein.[3][5][9] *Journal of Natural Products*, 65(4), 601-605.
- He, K., et al. (2000). Direct Analysis and Identification of Triterpene Glycosides by LC/MS in Black Cohosh, *Cimicifuga racemosa*. *Planta Medica*, 66(7), 635-640.
- Nian, Y., et al. (2012). One new and six known triterpene xylosides from *Cimicifuga racemosa*: FT-IR, Raman and NMR studies and DFT calculations.[13] *Journal of Molecular Structure*, 1029, 168-174.
- PubChem. 26-Deoxyactein (Compound Summary). National Library of Medicine.
- Avula, B., et al. (2007). Quantitative determination of triterpenoids and formononetin in rhizomes of Black cohosh (*Actaea racemosa*) and dietary supplements by LC-UV/ELSD. *Journal of Pharmaceutical and Biomedical Analysis*, 43(4), 1189-1199.

Need Custom Synthesis?

BenchChem offers custom synthesis for rare earth carbides and specific isotopic labeling.

Email: info@benchchem.com or [Request Quote Online](#).

Sources

- 1. Cimicifuga species identification by high performance liquid chromatography-photodiode array/mass spectrometric/evaporative light scattering detection for quality control of black cohosh products - PMC [[pmc.ncbi.nlm.nih.gov](https://pubmed.ncbi.nlm.nih.gov)]
- 2. [hort \[journals.ashs.org\]](https://journals.ashs.org)
- 3. Pharmacokinetics of 23-epi-26-deoxyactein in women following oral administration of a standardized extract of black cohosh - PMC [[pmc.ncbi.nlm.nih.gov](https://pubmed.ncbi.nlm.nih.gov)]
- 4. [pubs.acs.org \[pubs.acs.org\]](https://pubs.acs.org)
- 5. Isolation, Structure Elucidation, and Absolute Configuration of 26-Deoxyactein from Cimicifuga racemosa and Clarification of Nomenclature Associated with 27-Deoxyactein – ScienceOpen [scienceopen.com]
- 6. [hort \[journals.ashs.org\]](https://journals.ashs.org)
- 7. Biopharmaceutical classification of Cimicifuga racemosa extract Ze 450 [coms.events]
- 8. Differentiated Evaluation of Extract-Specific Evidence on Cimicifuga racemosa's Efficacy and Safety for Climacteric Complaints - PMC [[pmc.ncbi.nlm.nih.gov](https://pubmed.ncbi.nlm.nih.gov)]
- 9. Isolation, structure elucidation, and absolute configuration of 26-deoxyactein from Cimicifuga racemosa and clarification of nomenclature associated with 27-deoxyactein - PubMed [pubmed.ncbi.nlm.nih.gov]
- 10. [researchgate.net \[researchgate.net\]](https://researchgate.net)
- 11. 26-Deoxycimicifugoside | CAS:214146-75-5 | Manufacturer ChemFaces [chemfaces.com]
- 12. 26-DEOXYCIMICIFUGOSIDE | 214146-75-5 [m.chemicalbook.com]
- 13. One new and six known triterpene xylosides from Cimicifuga racemosa: FT-IR, Raman and NMR studies and DFT calculations - PubMed [pubmed.ncbi.nlm.nih.gov]
- To cite this document: BenchChem. [Application Note: Isolation and Purification of 26-Deoxycimicifugoside]. BenchChem, [2026]. [Online PDF]. Available at:

[<https://www.benchchem.com/product/b8236167/docs#application-note-isolation-and-purification-of-26-deoxycimicifugoside>]

Disclaimer & Data Validity:

The information provided in this document is for Research Use Only (RUO) and is strictly not intended for diagnostic or therapeutic procedures. While BenchChem strives to provide accurate protocols, we make no warranties, express or implied, regarding the fitness of this product for every specific experimental setup.

Technical Support: The protocols provided are for reference purposes. Unsure if this reagent suits your experiment?

Need Industrial/Bulk Grade? [Request Custom Synthesis Quote](#)

BenchChem

Our mission is to be the trusted global source of essential and advanced chemicals, empowering scientists and researchers to drive progress in science and industry.

Contact

Address: 3281 E Guasti Rd
Ontario, CA 91761, United States
Phone: (601) 213-4426
Email: info@benchchem.com

[Contact our Ph.D. Support Team for a compatibility check](#)