

An In-depth Technical Guide to the Photodegradation of Ethyl Linalool

Author: BenchChem Technical Support Team. **Date:** May 2026

Compound of Interest

Compound Name: Ethyl linalool

CAS No.: 92590-71-1

Cat. No.: B8231088

[Get Quote](#)

For Researchers, Scientists, and Drug Development Professionals

Disclaimer: Direct experimental data on the photodegradation products of **ethyl linalool** is not readily available in publicly accessible scientific literature. This guide is therefore based on established knowledge of the photodegradation of its close structural analog, linalool, and general principles of organic photochemistry. The proposed products, pathways, and experimental protocols are intended to serve as a foundational framework for research in this area.

Introduction

Ethyl linalool (3,7-dimethylnona-1,6-dien-3-ol) is a widely used fragrance ingredient, valued for its stable and pleasant floral, woody aroma. As with many unsaturated organic molecules, exposure to light, particularly ultraviolet (UV) radiation, can initiate degradation processes. This photodegradation can lead to the formation of new chemical entities, potentially altering the fragrance profile, and in some cases, leading to the formation of compounds with different toxicological or sensitizing properties. Understanding the photodegradation pathways and

identifying the resulting products are crucial for ensuring the stability, safety, and efficacy of products containing **ethyl linalool**.

This technical guide provides a hypothesized overview of the potential photodegradation products of **ethyl linalool**, detailed experimental protocols for their investigation, and a framework for data presentation and visualization.

Hypothesized Photodegradation Pathways and Products

Based on the known photodegradation and autoxidation of linalool, the photodegradation of **ethyl linalool** is likely to proceed via several mechanisms, including photooxidation and isomerization.^{[1][2][3]} The presence of two double bonds and a tertiary alcohol functional group makes **ethyl linalool** susceptible to radical-initiated reactions upon exposure to UV light, particularly in the presence of oxygen and photosensitizers.

1. Photooxidation and Hydroperoxide Formation:

The primary pathway for the photooxidation of allylic alcohols like linalool involves the formation of hydroperoxides.^{[2][4]} It is hypothesized that **ethyl linalool** will follow a similar path, leading to the formation of various hydroperoxides. These are often considered the primary oxidation products.

- Hypothesized Primary Products:
 - 7-hydroperoxy-3,7-dimethylnona-1,5-dien-3-ol
 - 6-hydroperoxy-3,7-dimethylnona-1,7-dien-3-ol

2. Secondary Degradation Products:

Hydroperoxides are often unstable and can further decompose to form a variety of secondary products, including alcohols, aldehydes, and ketones.^[5] Additionally, isomerization and cyclization reactions can occur.

- Hypothesized Secondary Products:

- From Hydroperoxide Decomposition:
 - 2,6-dimethylnona-3,7-diene-2,6-diol
 - 6-hydroxy-2,6-dimethylnona-2,7-dienal
- Isomerization and Rearrangement Products: Similar to the thermal degradation of linalool which yields compounds like β -myrcene, ocimene isomers, limonene, and terpinolene, **ethyl linalool** might undergo analogous rearrangements.^{[1][6]}

Data Presentation: Quantitative Analysis of Photodegradation Products

To facilitate a clear comparison of results, all quantitative data should be summarized in a structured table.

Photodegradation Product	Retention Time (min)	Molecular Formula	Molecular Weight (g/mol)	Quantification Ion (m/z)	Concentration ($\mu\text{g/mL}$) at different irradiation times
e.g., 7-hydroperoxy-3,7-dimethylnona-1,5-dien-3-ol	C11H20O3	200.28	e.g., 0h, 2h, 4h, 8h, 24h		
e.g., 6-hydroxy-2,6-dimethylnona-2,7-dienal	C11H18O2	182.26			
... (other identified products)					

Experimental Protocols

The following are detailed methodologies for key experiments to investigate the photodegradation of **ethyl linalool**.

1. Sample Preparation and Irradiation:

- Objective: To expose a solution of **ethyl linalool** to a controlled source of UV radiation.
- Materials:
 - **Ethyl linalool** (high purity, >98%)
 - Solvent (e.g., ethanol, acetonitrile, or a non-reactive solvent transparent to the irradiation wavelength)
 - Quartz cuvettes or a photoreactor with a quartz window
 - UV lamp (e.g., mercury lamp with specific filters, or a chamber with controlled UVA/UVB lamps, such as a Rayonet reactor with 350 nm lamps).[5]
- Procedure:
 - Prepare a solution of **ethyl linalool** in the chosen solvent at a known concentration (e.g., 100 µg/mL).
 - Transfer the solution to the quartz cuvettes or photoreactor.
 - Place the samples at a fixed distance from the UV lamp.
 - Irradiate the samples for specific time intervals (e.g., 0, 2, 4, 8, 24 hours).
 - At each time point, withdraw an aliquot of the sample for analysis.
 - Store the collected samples in the dark at low temperatures (e.g., 4°C) to prevent further degradation before analysis.

2. Analytical Methodology: Identification and Quantification of Photodegradation Products:

- Objective: To separate, identify, and quantify the photodegradation products.
- Instrumentation: A Gas Chromatograph coupled with a Mass Spectrometer (GC-MS) is the preferred instrument for analyzing volatile and semi-volatile terpenes and their degradation products.[7][8] High-Performance Liquid Chromatography (HPLC) can also be utilized, especially for less volatile or thermally labile products.[9]
- GC-MS Protocol:
 - Column: Use a non-polar or medium-polarity capillary column (e.g., HP-5MS, DB-5).
 - Injection: Use a split/splitless or cool on-column injector to prevent thermal degradation of analytes.[10]
 - Oven Temperature Program: Start at a low temperature (e.g., 40°C) and ramp up to a higher temperature (e.g., 250°C) to ensure separation of compounds with different boiling points.
 - Carrier Gas: Helium at a constant flow rate.
 - Mass Spectrometer: Operate in electron ionization (EI) mode. Scan a mass range of m/z 40-400.
 - Identification: Identify the degradation products by comparing their mass spectra with a reference library (e.g., NIST, Wiley) and, if possible, by comparing their retention times and mass spectra with authentic standards.
 - Quantification: Create a calibration curve for **ethyl linalool** and any available standards of potential degradation products. For unidentified products, semi-quantification can be performed using the peak area of a surrogate standard.
- HPLC-MS Protocol:
 - Column: A reverse-phase C18 column is suitable for separating compounds of varying polarity.
 - Mobile Phase: A gradient of water and an organic solvent like acetonitrile or methanol.

- Detector: A Diode Array Detector (DAD) to obtain UV spectra and a Mass Spectrometer (MS) for mass information. High-resolution mass spectrometry can aid in determining the elemental composition of the products.[9]
- Ionization: Use a soft ionization technique like Electrospray Ionization (ESI) or Atmospheric Pressure Chemical Ionization (APCI).

Mandatory Visualizations

Experimental Workflow for Ethyl Linalool Photodegradation Study

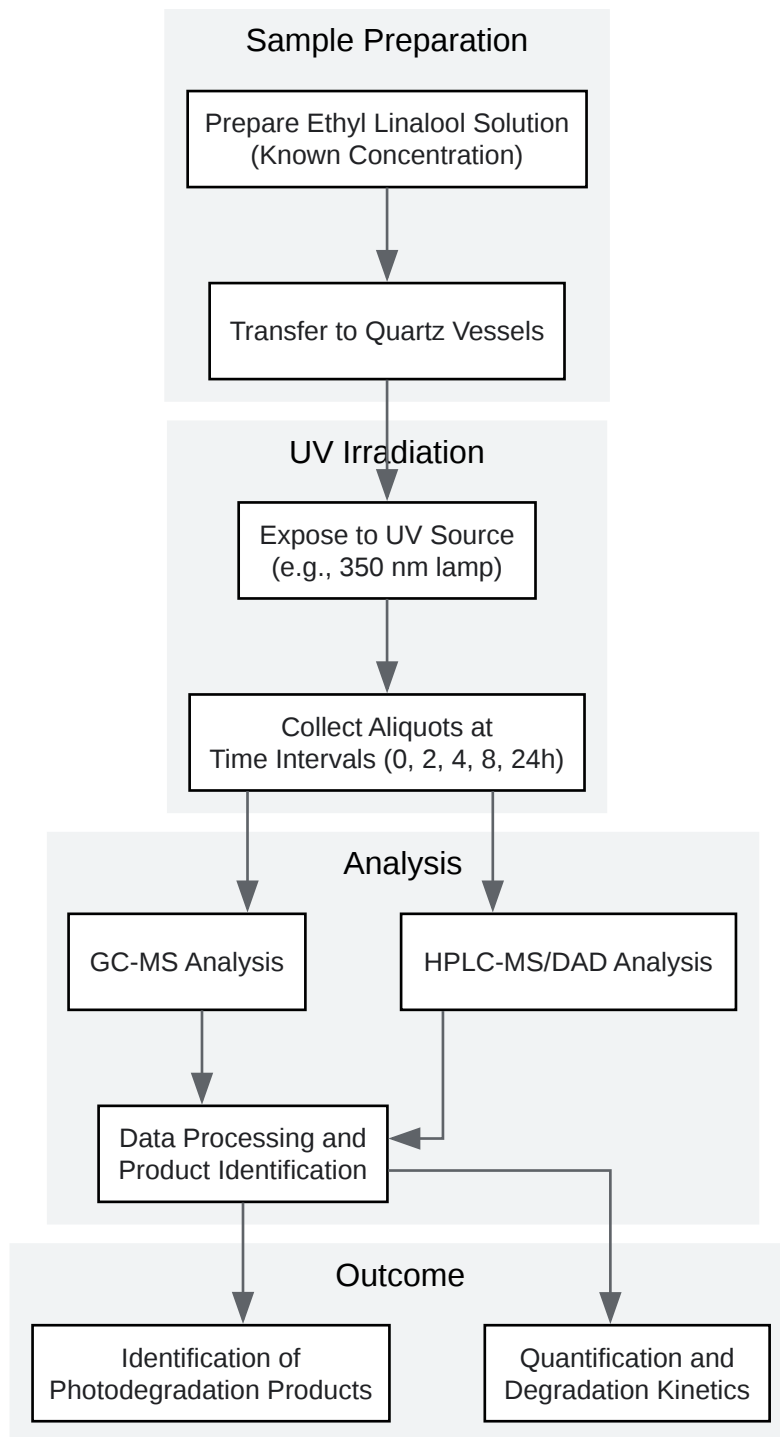

[Click to download full resolution via product page](#)

Caption: Workflow for the investigation of **ethyl linalool** photodegradation.

Hypothesized Photooxidation of Ethyl Linalool

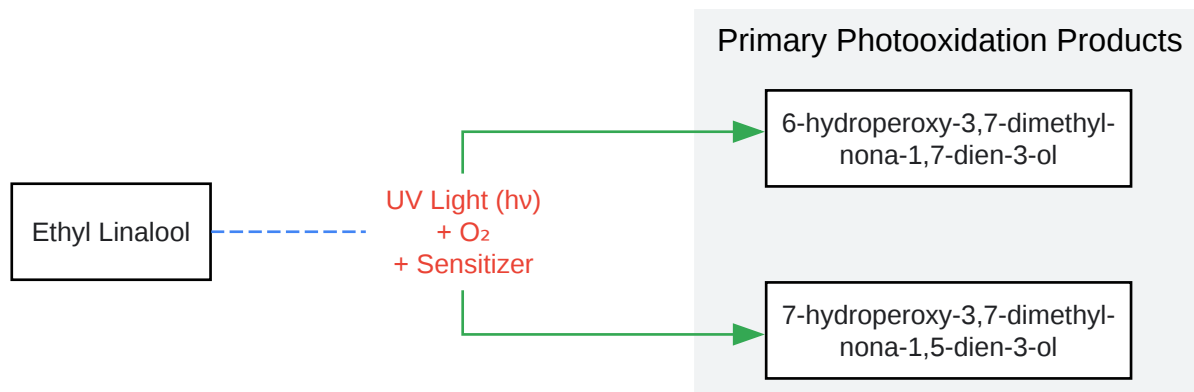

[Click to download full resolution via product page](#)

Need Custom Synthesis?

BenchChem offers custom synthesis for rare earth carbides and specific isotopic labeling.

Email: info@benchchem.com or [Request Quote Online](#).

References

- [1. benchchem.com \[benchchem.com\]](https://www.benchchem.com)
- [2. researchgate.net \[researchgate.net\]](https://www.researchgate.net)
- [3. Oxidation Mechanism and Toxicity Evolution of Linalool, a Typical Indoor Volatile Chemical Product - PMC \[pmc.ncbi.nlm.nih.gov\]](https://pubmed.ncbi.nlm.nih.gov/30111111/)
- [4. datasheets.scbt.com \[datasheets.scbt.com\]](https://www.datasheets.scbt.com)
- [5. pubs.acs.org \[pubs.acs.org\]](https://pubs.acs.org)
- [6. Thermal Degradation of Linalool-Chemotype Cinnamomum osmophloeum Leaf Essential Oil and Its Stabilization by Microencapsulation with \$\beta\$ -Cyclodextrin - PubMed \[pubmed.ncbi.nlm.nih.gov\]](https://pubmed.ncbi.nlm.nih.gov/30111111/)
- [7. Terpenes in food and plant samples: Updates on sampling, pretreatment and analysis techniques - Arabian Journal of Chemistry \[arabjchem.org\]](https://www.arabjchem.org)
- [8. youtube.com \[youtube.com\]](https://www.youtube.com)

- [9. Detection of potentially skin sensitizing hydroperoxides of linalool in fragranced products - PubMed \[pubmed.ncbi.nlm.nih.gov\]](#)
- [10. Cannabis-Derived Terpene Testing: Methods for Accurate Solvent Analysis | Terpene Belt Farms \[terpenebeltfarms.com\]](#)
- To cite this document: BenchChem. [An In-depth Technical Guide to the Photodegradation of Ethyl Linalool]. BenchChem, [2026]. [Online PDF]. Available at: [\[https://www.benchchem.com/product/b8231088/docs#an-in-depth-technical-guide-to-the-photodegradation-of-ethyl-linalool\]](https://www.benchchem.com/product/b8231088/docs#an-in-depth-technical-guide-to-the-photodegradation-of-ethyl-linalool)

Disclaimer & Data Validity:

The information provided in this document is for Research Use Only (RUO) and is strictly not intended for diagnostic or therapeutic procedures. While BenchChem strives to provide accurate protocols, we make no warranties, express or implied, regarding the fitness of this product for every specific experimental setup.

Technical Support: The protocols provided are for reference purposes. Unsure if this reagent suits your experiment?

Need Industrial/Bulk Grade? [Request Custom Synthesis Quote](#)

BenchChem

Our mission is to be the trusted global source of essential and advanced chemicals, empowering scientists and researchers to drive progress in science and industry.

Contact

Address: 3281 E Guasti Rd
Ontario, CA 91761, United States
Phone: (601) 213-4426
Email: info@benchchem.com

[Contact our Ph.D. Support Team for a compatibility check](#)

