

# Technical Support Center: Quality Control Measures for MP07-66

**Author:** BenchChem Technical Support Team. **Date:** April 2026

## Compound of Interest

Compound Name: MP07-66

Cat. No.: B8229418

[Get Quote](#)

Welcome to the technical support center for **MP07-66**. This resource is designed to assist researchers, scientists, and drug development professionals in ensuring the quality and consistency of **MP07-66** from various suppliers. Below you will find troubleshooting guides, frequently asked questions (FAQs), and detailed experimental protocols to address common issues encountered during experimental workflows.

## Troubleshooting Guides and FAQs

This section addresses potential issues and questions regarding the quality and handling of **MP07-66**.

Question 1: I am observing lower than expected potency of **MP07-66** in my cell-based assays compared to published data. What could be the cause?

Answer: Discrepancies in potency can arise from several factors related to the quality of the compound:

- Purity: The actual purity of the **MP07-66** lot may be lower than specified. Impurities can interfere with the assay or compete with the active compound, leading to reduced apparent

potency. We recommend verifying the purity of your batch using HPLC analysis (see Experimental Protocols section).

- **Presence of Isomers or Related Impurities:** The synthesis of **MP07-66** may result in the formation of structurally related impurities or isomers that have lower activity. These may not be fully resolved from the main peak in a low-resolution HPLC analysis. High-resolution mass spectrometry can help identify such impurities.
- **Compound Stability and Storage:** **MP07-66**, like many small molecules, can degrade if not stored correctly.<sup>[1]</sup> Ensure the compound is stored at the recommended temperature (-20°C or -80°C for solutions) and protected from light and repeated freeze-thaw cycles. Degradation can lead to a decrease in the concentration of the active compound.
- **Solubility Issues:** Poor solubility of **MP07-66** in your assay buffer can lead to precipitation and a lower effective concentration. Ensure the final solvent concentration (e.g., DMSO) is compatible with your experimental system and that the compound is fully dissolved.

Question 2: My batch of **MP07-66** shows a different color/appearance compared to previous batches. Should I be concerned?

Answer: A change in the physical appearance of the compound, such as color, can be an indicator of impurities or degradation. While a slight variation in color might not always impact activity, it warrants further investigation. We recommend performing a purity analysis (e.g., HPLC) and comparing the impurity profile with that of a previous batch that performed as expected.

Question 3: I am seeing a secondary peak in my HPLC analysis of **MP07-66**. How can I identify it?

Answer: The presence of a secondary peak indicates an impurity. To identify this impurity, we recommend the following:

- **Mass Spectrometry (MS):** Coupling the HPLC to a mass spectrometer (LC-MS) is the most effective way to determine the molecular weight of the compound in the secondary peak. This can provide clues as to its identity (e.g., a known synthetic precursor, a degradation product, or a related impurity).

- Nuclear Magnetic Resonance (NMR) Spectroscopy: If the impurity can be isolated in sufficient quantity,  $^1\text{H}$  and  $^{13}\text{C}$  NMR spectroscopy can provide detailed structural information to aid in its identification.

Question 4: How can I ensure the identity and concentration of my **MP07-66** stock solution are correct?

Answer: To confirm the identity and concentration of your stock solution, you can use the following methods:

- Identity Confirmation:
  - Mass Spectrometry: Verify that the molecular weight of your compound corresponds to that of **MP07-66** (323.47 g/mol ).<sup>[1]</sup>
  - NMR Spectroscopy: Compare the  $^1\text{H}$  NMR spectrum of your compound to a reference spectrum to confirm its chemical structure.
- Concentration Verification:
  - Quantitative NMR (qNMR): This technique can be used to accurately determine the concentration of your stock solution by comparing the integral of a compound peak to that of a certified internal standard of known concentration.
  - UV-Vis Spectroscopy: If you have a known extinction coefficient for **MP07-66**, you can use UV-Vis spectroscopy to determine the concentration based on its absorbance at a specific wavelength.

## Data Presentation: Comparative Quality Control

### Data for MP07-66

The following table summarizes typical quality control data for **MP07-66** from three hypothetical suppliers. This data is for illustrative purposes to highlight potential variations.

Parameter	Supplier A	Supplier B	Supplier C	Acceptance Criteria
Appearance	White to off-white solid	Light yellow solid	White crystalline powder	White to off-white solid
Purity (by HPLC)	99.2%	97.5%	99.8%	≥ 98.0%
Identity (by <sup>1</sup> H NMR)	Conforms to structure	Conforms to structure	Conforms to structure	Conforms to structure
Identity (by MS)	m/z = 324.25 [M+H] <sup>+</sup>	m/z = 324.25 [M+H] <sup>+</sup>	m/z = 324.25 [M+H] <sup>+</sup>	m/z = 324.25 ± 0.1 [M+H] <sup>+</sup>
Major Impurity (by HPLC)	0.5% (at RRT 1.2)	1.8% (at RRT 0.8)	0.1% (at RRT 1.2)	≤ 0.5% for any single impurity
Total Impurities (by HPLC)	0.8%	2.5%	0.2%	≤ 2.0%
Residual Solvents (by GC)	< 0.1%	< 0.5%	< 0.1%	As per ICH guidelines
Water Content (by Karl Fischer)	0.2%	0.8%	0.1%	≤ 1.0%

RRT = Relative Retention Time

## Experimental Protocols

Detailed methodologies for key quality control experiments are provided below.

### High-Performance Liquid Chromatography (HPLC) for Purity Analysis

Objective: To determine the purity of **MP07-66** and quantify any impurities.

Methodology:

- Instrumentation: A standard HPLC system equipped with a UV detector.

- Column: C18 reverse-phase column (e.g., 4.6 x 150 mm, 5 µm particle size).
- Mobile Phase:
  - A: 0.1% Formic acid in water
  - B: 0.1% Formic acid in acetonitrile
- Gradient:
  - 0-2 min: 10% B
  - 2-15 min: 10% to 90% B
  - 15-18 min: 90% B
  - 18-20 min: 90% to 10% B
  - 20-25 min: 10% B
- Flow Rate: 1.0 mL/min.
- Detection Wavelength: 254 nm.
- Injection Volume: 10 µL.
- Sample Preparation: Prepare a 1 mg/mL solution of **MP07-66** in DMSO.
- Analysis: The purity is calculated based on the area percentage of the main peak relative to the total peak area in the chromatogram.

## Liquid Chromatography-Mass Spectrometry (LC-MS) for Identity Confirmation

Objective: To confirm the molecular weight of **MP07-66**.

Methodology:

- Instrumentation: An HPLC system coupled to a mass spectrometer (e.g., a single quadrupole or time-of-flight analyzer).
- LC Conditions: Use the same HPLC method as described above.
- Mass Spectrometry Settings:
  - Ionization Mode: Electrospray Ionization (ESI), positive mode.
  - Scan Range: m/z 100-500.
  - Capillary Voltage: 3.5 kV.
  - Cone Voltage: 30 V.
- Analysis: The resulting mass spectrum should show a prominent peak corresponding to the protonated molecule of **MP07-66** ( $[M+H]^+$ ) at approximately m/z 324.25.

## $^1\text{H}$ NMR for Structural Confirmation

Objective: To confirm the chemical structure of **MP07-66**.

Methodology:

- Instrumentation: A 400 MHz or higher NMR spectrometer.
- Sample Preparation: Dissolve 5-10 mg of **MP07-66** in approximately 0.7 mL of a deuterated solvent (e.g., DMSO- $d_6$  or  $\text{CDCl}_3$ ).
- Acquisition Parameters:
  - Pulse Program: Standard 1D proton experiment.
  - Number of Scans: 16 or 32.
  - Relaxation Delay: 1-2 seconds.
- Analysis: The acquired  $^1\text{H}$  NMR spectrum should be consistent with the known chemical structure of **MP07-66**, showing the expected chemical shifts, splitting patterns, and

integrations for all protons.

## **Mandatory Visualizations**

### **Signaling Pathway of MP07-66 Action**

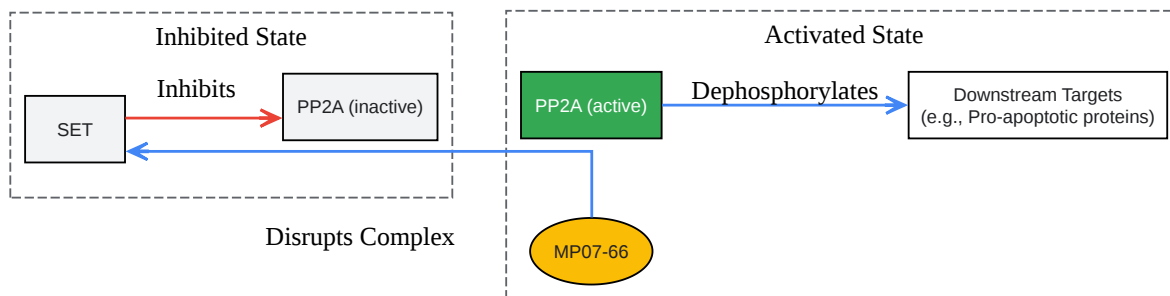

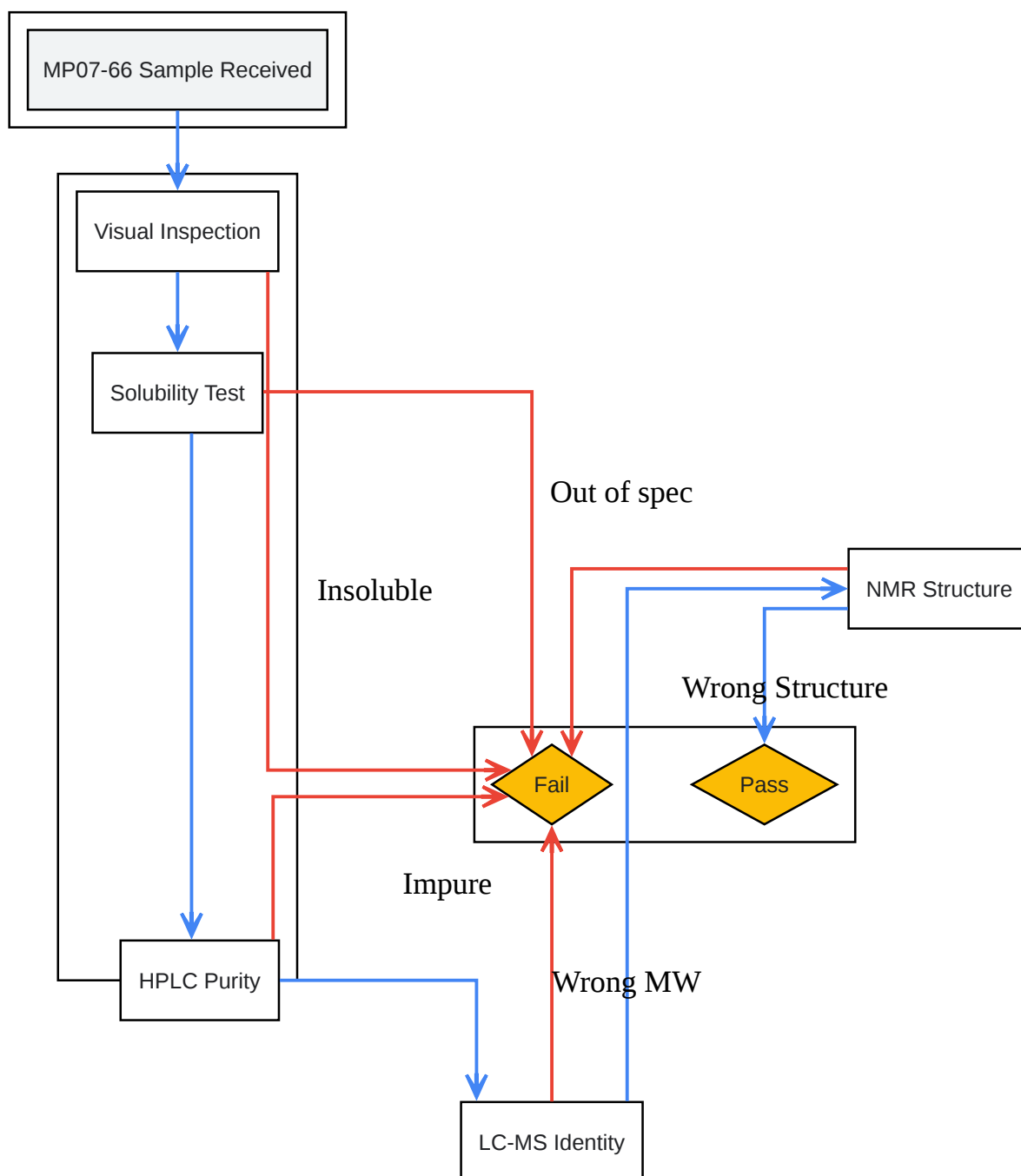

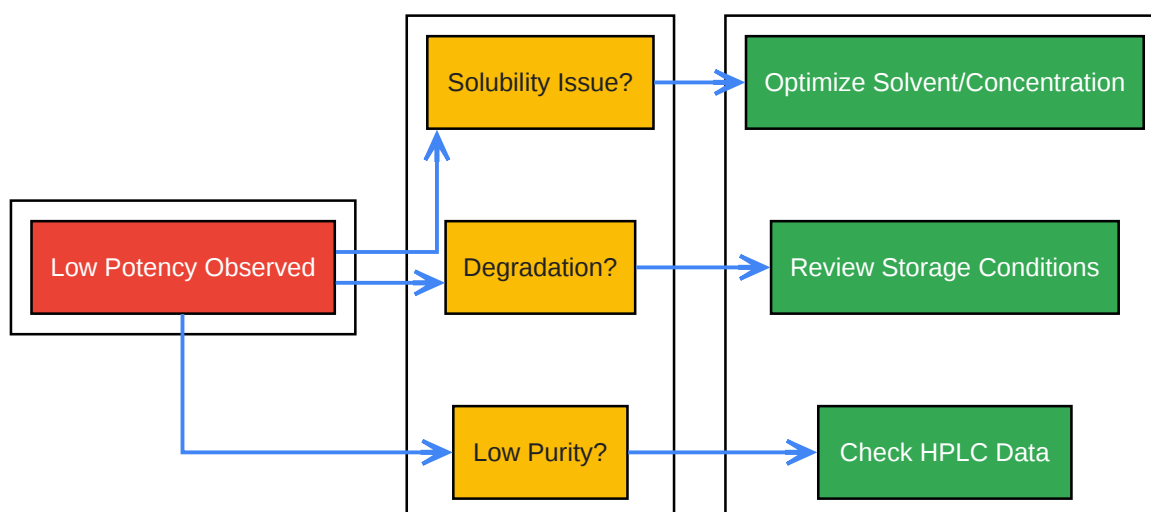

[Click to download full resolution via product page](#)

### Need Custom Synthesis?

BenchChem offers custom synthesis for rare earth carbides and specific isotopic labeling.

Email: [info@benchchem.com](mailto:info@benchchem.com) or [Request Quote Online](#).

## References

- 1. [medchemexpress.com](https://www.medchemexpress.com) [[medchemexpress.com](https://www.medchemexpress.com)]
- To cite this document: BenchChem. [Technical Support Center: Quality Control Measures for MP07-66]. BenchChem, [2026]. [Online PDF]. Available at: [<https://www.benchchem.com/product/b8229418/docs#technical-support-center-quality-control-measures-for-mp07-66>]

### Disclaimer & Data Validity:

The information provided in this document is for Research Use Only (RUO) and is strictly not intended for diagnostic or therapeutic procedures. While BenchChem strives to provide accurate protocols, we make no warranties, express or implied, regarding the fitness of this product for every specific experimental setup.

**Technical Support:** The protocols provided are for reference purposes. Unsure if this reagent suits your experiment?

**Need Industrial/Bulk Grade?** [Request Custom Synthesis Quote](#)

## BenchChem

Our mission is to be the trusted global source of essential and advanced chemicals, empowering scientists and researchers to drive progress in science and industry.

### Contact

Address: 3281 E Guasti Rd  
Ontario, CA 91761, United States  
Phone: (601) 213-4426  
Email: [info@benchchem.com](mailto:info@benchchem.com)

[Contact our Ph.D. Support Team for a compatibility check](#)