

Comparative Guide: Mass Spectrometry Fragmentation Strategies for Halogenated Piperidines

Author: BenchChem Technical Support Team. **Date:** April 2026

Compound of Interest

Compound Name: (2R,4R)-4-fluoro-2-methylpiperidine hydrochloride
Cat. No.: B8229546

[Get Quote](#)

Executive Summary

Halogenated piperidines are critical pharmacophores in medicinal chemistry, often employed to modulate basicity (pK_a), block metabolic hotspots (e.g., CYP450 oxidation), or improve potency via halogen bonding. However, their structural characterization presents unique challenges. The electron-withdrawing nature of halogens (F, Cl, Br) alters standard fragmentation pathways, and distinguishing positional isomers (e.g., 3-fluoro- vs. 4-fluoropiperidine) requires specific analytical strategies.

This guide compares the two dominant analytical "products"—Electron Ionization (EI) GC-MS and Electrospray Ionization (ESI) MS/MS—evaluating their performance in structural elucidation, sensitivity, and isomer differentiation.

Quick Comparison Matrix

Feature	Method A: EI-GC/MS (Hard Ionization)	Method B: ESI-MS/MS (Soft Ionization)
Primary Utility	Library matching, impurity profiling	Bioanalysis, metabolite ID, isomer differentiation
Dominant Mechanism	Radical-site induced -cleavage	Charge-site driven neutral loss (HX)
Isomer Resolution	Low (Spectra often identical for regioisomers)	High (Distinguishable via MS/MS collision energy)
Key Diagnostic	Iminium ions (84, 118)	Neutral loss of HF/HCl (20/36)
Sample Requirement	Volatile, non-polar derivatives	Polar, aqueous soluble

Technical Deep Dive: Fragmentation Mechanisms

To select the correct analytical approach, one must understand the causality behind the fragmentation.

Electron Ionization (EI): The -Cleavage Dominance

In EI (70 eV), the radical cation (

) is formed primarily by removing an electron from the nitrogen lone pair. The driving force is the formation of a resonance-stabilized iminium ion.^[1]

- Mechanism: Homolytic cleavage of the C-C bond to the nitrogen.
- The Problem with Halogens: For 3- and 4-halogenated piperidines, the -cleavage often results in identical mass fragments because the halogen is located on the or carbon, which is not directly involved in the primary bond breaking.

- Result: 3-chloropiperidine and 4-chloropiperidine produce nearly indistinguishable EI spectra dominated by the unsubstituted iminium ring or loss of the halogen radical.

ESI-MS/MS: Protonation and Neutral Loss

In ESI, the molecule forms an even-electron ion

- . Fragmentation is driven by "mobile proton" chemistry.
- Mechanism: The proton localizes on the nitrogen. Upon collisional activation (CID), the energy induces an E2-type elimination or neighboring group participation.
- Halogen Specificity: The dominant pathway is the Neutral Loss of HX (HF, HCl, HBr).
 - 4-Halopiperidines: Tend to lose HX to form a conjugated diene system (tetrahydropyridine cation).
 - 3-Halopiperidines: The proximity of the halogen to the nitrogen (3-position) allows for "neighboring group participation" (NGP) or specific ring contractions that are energetically distinct from the 4-isomer.

Visualization of Signaling Pathways

The following diagram illustrates the divergent fragmentation logic between EI and ESI modes for a generic 4-chloropiperidine.

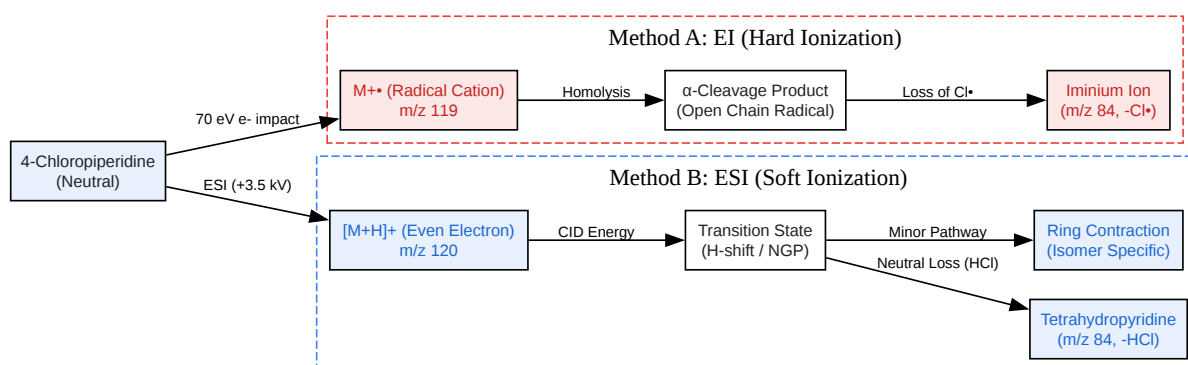

[Click to download full resolution via product page](#)

Caption: Comparison of Radical-site driven cleavage (EI) vs. Charge-site driven neutral loss (ESI) for 4-chloropiperidine.

Experimental Protocol: Differentiating Isomers (3-F vs 4-F)

This protocol validates the "Product B" (ESI-MS/MS) approach for distinguishing positional isomers, which is the superior method for this application.

Objective

To differentiate 3-fluoropiperidine from 4-fluoropiperidine using Energy-Resolved Mass Spectrometry (ER-MS).

Materials

- Analytes: 3-fluoropiperidine HCl, 4-fluoropiperidine HCl.
- Solvent: 50:50 Methanol:Water + 0.1% Formic Acid.
- Instrument: Q-TOF or Triple Quadrupole MS (e.g., Sciex 6500+ or Agilent 6495).

Step-by-Step Methodology

- Sample Preparation:
 - Dilute standards to 1 μM (approx. 100 ng/mL) in the solvent mixture.
 - Note: Avoid glass vials if analyzing trace levels; use polypropylene to prevent adsorption.
- Direct Infusion Setup:
 - Flow rate: 10 $\mu\text{L}/\text{min}$.
 - Source Temp: 300°C.
 - Ion Spray Voltage: 4500 V.
- Precursor Isolation:
 - Select

at m/z 104.1 (for Fluoropiperidine).
 - Isolation width: ± 1 Da (Unit resolution).
- Energy-Resolved Breakdown Curve:
 - Instead of a single collision energy (CE), ramp the CE from 5 eV to 50 eV in 5 eV increments.
 - Monitor two transitions:
 - Transition 1 (Neutral Loss):

(Loss of HF,

20 Da).
 - Transition 2 (Ring Cleavage):

(Retro-Diels-Alder type fragment).

- Data Interpretation (The "Trust" Step):
 - 4-Fluoropiperidine: The loss of HF (84) appears at lower collision energies (approx 10-15 eV) because the elimination yields a conjugated system.
 - 3-Fluoropiperidine: The loss of HF requires higher energy or shows a different ratio of 56 vs 84 due to the inductive destabilization of the developing cation by the closer nitrogen.
 - Validation: Plot the ratio of Intensity(84)/Intensity(56) vs. CE. The curves will diverge, providing a unique fingerprint for each isomer.

Quantitative Data Comparison

The following table summarizes expected ion abundances based on literature mechanisms for halogenated piperidines.

Compound	Precursor ()	Major Fragment 1 ()	Major Fragment 2 ()	Diagnostic Feature
4-Fluoropiperidine	104	84 (Loss of HF)	56 (Ring cleavage)	High intensity 84 at low CE.
3-Fluoropiperidine	104	84 (Loss of HF)	44 (Ethylamine fragment)	Distinct breakdown curve; higher relative 44/56 ratio.
4-Chloropiperidine	120	84 (Loss of HCl)	56	Chlorine isotope pattern (3:1) visible in precursor but lost in fragment 84.
4-Bromopiperidine	164	84 (Loss of HBr)	56	Labile C-Br bond; HBr loss occurs at very low CE (soft fragmentation).

References

- Chemistry LibreTexts. (2023). Mass Spectrometry - Fragmentation Patterns. Retrieved from [\[Link\]](#)
- Scientific Update. (2019). Syn-3-Fluoro-4-aminopiperidine - a story from multiple orientations. Retrieved from [\[Link\]](#)
- National Institute of Justice. (2009).[2] Differentiation of the Regioisomeric 2, 3 and 4-Trifluoromethylphenylpiperazines by GC-IRD and GC-MS. Retrieved from [\[Link\]](#)

- Save My Exams. (2025). Mass Spectrometry Fragmentation Patterns (HL). Retrieved from [\[Link\]](#)

Need Custom Synthesis?

BenchChem offers custom synthesis for rare earth carbides and specific isotopic labeling.

Email: info@benchchem.com or [Request Quote Online](#).

Sources

- 1. [benchchem.com](https://www.benchchem.com) [[benchchem.com](https://www.benchchem.com)]
- 2. Differentiation of the Regioisomeric 2,3 and 4-Trifluoromethylphenylpiperazines (TFMPP) by GC-IR and GC-MS | National Institute of Justice [[nij.ojp.gov](https://www.nij.ojp.gov)]
- To cite this document: BenchChem. [Comparative Guide: Mass Spectrometry Fragmentation Strategies for Halogenated Piperidines]. BenchChem, [2026]. [Online PDF]. Available at: [<https://www.benchchem.com/product/b8229546/docs#comparative-guide-mass-spectrometry-fragmentation-strategies-for-halogenated-piperidines>]

Disclaimer & Data Validity:

The information provided in this document is for Research Use Only (RUO) and is strictly not intended for diagnostic or therapeutic procedures. While BenchChem strives to provide accurate protocols, we make no warranties, express or implied, regarding the fitness of this product for every specific experimental setup.

Technical Support: The protocols provided are for reference purposes. Unsure if this reagent suits your experiment?

Need Industrial/Bulk Grade? [Request Custom Synthesis Quote](#)

BenchChem

Our mission is to be the trusted global source of essential and advanced chemicals, empowering scientists and researchers to drive progress in science and industry.

Contact

Address: 3281 E Guasti Rd

Ontario, CA 91761, United States

Phone: (601) 213-4426

Email: info@benchchem.com

[Contact our Ph.D. Support Team for a compatibility check](#)