

# Comparative FTIR Reference Guide: 4-((6,7-Dimethoxyquinolin-4-yl)amino)phenol

**Author:** BenchChem Technical Support Team. **Date:** May 2026

## Compound of Interest

Compound Name: 4-((6,7-Dimethoxyquinolin-4-yl)amino)phenol

Cat. No.: B8224468

[Get Quote](#)

## Executive Summary & Chemical Identity

This guide provides a technical reference for the Fourier Transform Infrared (FTIR) characterization of **4-((6,7-Dimethoxyquinolin-4-yl)amino)phenol** (CAS: 748707-58-6).[1]

This molecule is a critical pharmacophore in the synthesis of Tyrosine Kinase Inhibitors (TKIs), functioning either as a direct precursor or a specific process impurity in the manufacturing of drugs like Cabozantinib and Lenvatinib. Its structural integrity is defined by the amino-bridge linking the quinoline core and the phenol ring, a feature that must be rigorously distinguished from its ether-bridged analog (4-((6,7-dimethoxyquinolin-4-yl)oxy)aniline) during Quality Control (QC).[1]

## Chemical Profile

Property	Specification
Chemical Name	4-((6,7-Dimethoxyquinolin-4-yl)amino)phenol
CAS Number	748707-58-6
Molecular Formula	C <sub>17</sub> H <sub>16</sub> N <sub>2</sub> O <sub>3</sub>
Molecular Weight	296.32 g/mol
Key Functional Groups	Secondary Amine (Bridge), Phenolic Hydroxyl, Methoxy ethers, Quinoline Ring

## Experimental Methodology (Protocol)

To ensure reproducible spectral data, the following acquisition protocol is recommended. This methodology minimizes hygroscopic interference, which is critical when analyzing the phenolic hydroxyl region.

## Sample Preparation & Acquisition

- Technique: Attenuated Total Reflectance (ATR) is preferred for rapid ID; KBr Pellet is recommended for high-resolution structural elucidation.<sup>[1]</sup>
- Crystal Material (ATR): Diamond or ZnSe (Diamond preferred for hardness).
- Resolution: 4 cm<sup>-1</sup><sup>[1]</sup>
- Scans: 32 (Screening) or 64 (Final QC).
- Spectral Range: 4000 – 400 cm<sup>-1</sup><sup>[1][2][3][4]</sup>

## Critical Pre-Treatment Step

“

*Expert Insight: The phenolic -OH group is prone to hydrogen bonding with atmospheric moisture.[1] Dry the sample in a vacuum desiccator over P<sub>2</sub>O<sub>5</sub> for 4 hours prior to analysis to resolve the sharp O-H stretch from the broad water band.*

## Spectral Analysis & Band Assignment

The FTIR spectrum of **4-((6,7-Dimethoxyquinolin-4-yl)amino)phenol** is a superposition of the electron-rich quinoline core and the para-substituted phenol.[1] The table below details the diagnostic bands.

### Table 1: Diagnostic FTIR Bands & Assignments

Frequency Region (cm <sup>-1</sup> )	Functional Group	Vibrational Mode	Diagnostic Notes
3200 – 3500	O-H (Phenol)	Stretching (Broad)	Broad band due to intermolecular H-bonding.[1] Distinguishes this compound from non-phenolic precursors.
3350 – 3420	N-H (Secondary)	Stretching (Sharp)	A single sharp peak characteristic of the secondary amine bridge (-NH-). Crucial for distinguishing from the ether analog.
2830 – 3000	C-H (Methoxy/Aromatic)	Stretching	C-H (sp <sup>3</sup> ) of -OCH <sub>3</sub> groups typically appear ~2835 and 2940 cm <sup>-1</sup> .
1580 – 1620	C=N / C=C (Quinoline)	Ring Stretching	Strong, sharp bands characteristic of the heteroaromatic quinoline core.
1500 – 1520	N-H (Amine)	Bending (Scissoring)	Deformation band of the secondary amine bridge.
1200 – 1280	C-O-C (Aryl Ether)	Asymmetric Stretch	Strong intensity. Corresponds to the methoxy groups at positions 6 and 7.[5] [6]
1230 – 1260	C-N (Aromatic Amine)	Stretching	Interaction between the quinoline ring and the bridging nitrogen.

---

800 – 850	C-H (Aromatic)	Out-of-plane Bending	Two adjacent hydrogens on the quinoline and phenol rings (para-substitution pattern). [1]
-----------	----------------	----------------------	--

---

## Comparative Analysis: Impurity & Analog Differentiation

In drug development, this molecule is often confused with its ether-linked counterpart or the starting materials. The following comparison highlights the spectral "fingerprints" required for differentiation.

### Comparison 1: Amino-Linkage vs. Ether-Linkage

The primary risk in synthesis is the formation of the ether bond instead of the amine bond, or the presence of the 4-((6,7-dimethoxyquinolin-4-yl)oxy)aniline intermediate.[1]

Feature	Target: Amino-Phenol (CAS 748707-58-6)	Analog: Ether-Aniline (CAS 190728-25-7)
Linkage	-NH- (Secondary Amine)	-O- (Ether)
Terminal Group	-OH (Phenol)	-NH <sub>2</sub> (Primary Amine)
3300-3500 cm <sup>-1</sup>	Single N-H spike + Broad O-H	Doublet N-H (Primary amine) + No Broad O-H
1000-1100 cm <sup>-1</sup>	C-N Stretch (Strong)	C-O-C Stretch (Stronger)

### Comparison 2: Target vs. Starting Materials

- 4-Chloro-6,7-dimethoxyquinoline: Lacks the O-H (3200+) and N-H (3350+) bands. Contains a C-Cl stretch (~700-800 cm<sup>-1</sup>).[1]
- 4-Aminophenol: Shows a primary amine doublet (~3300/3400 cm<sup>-1</sup>) instead of the secondary amine singlet. Lacks the Quinoline ring modes (1580-1620 cm<sup>-1</sup>).

## Structural Visualization & Logic

The following diagram maps the chemical structure to the specific spectral regions discussed above.

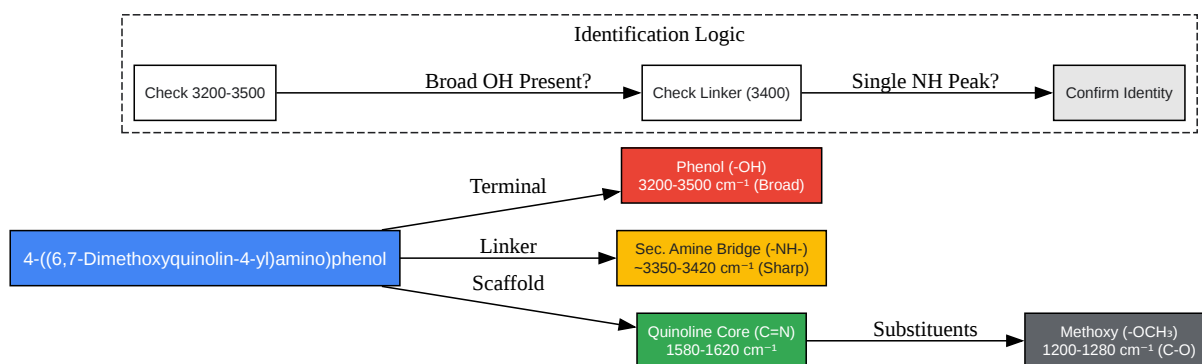

[Click to download full resolution via product page](#)

Figure 1: Functional group mapping and spectral identification logic for the target molecule.

## References

- National Institute of Standards and Technology (NIST). Phenol, 4-amino- Infrared Spectrum. [1] NIST Chemistry WebBook, SRD 69.[7] Available at: [\[Link\]](#) (Used for Phenol/Amine fragment correlation).
- Pharmaffiliates. 4-((6,7-Dimethoxyquinolin-4-yl)amino)phenol Product Standard. Available at: [\[Link\]](#) (Verified CAS and chemical identity).
- ResearchGate. FTIR and FT-Raman Spectral Investigations on 4-Aminoquinoline and 5-Aminoquinoline. Available at: [\[Link\]](#) (Used for Quinoline core vibrational assignments).
- National Institutes of Health (NIH) - PubChem. N-(3,4-dimethoxyphenyl)-6,7-dimethoxyquinazolin-4-amine.[1] Available at: [\[Link\]](#) (Structural analog comparison).

### Need Custom Synthesis?

BenchChem offers custom synthesis for rare earth carbides and specific isotopic labeling.

Email: [info@benchchem.com](mailto:info@benchchem.com) or [Request Quote Online](#).

## Sources

- 1. [190728-25-7|4-\(\(6,7-Dimethoxyquinolin-4-yl\)oxy\)aniline|BLD Pharm \[bldpharm.com\]](#)
- 2. [researchgate.net \[researchgate.net\]](#)
- 3. [researchgate.net \[researchgate.net\]](#)
- 4. [mdpi.com \[mdpi.com\]](#)
- 5. [bocsci.com \[bocsci.com\]](#)
- 6. [researchgate.net \[researchgate.net\]](#)
- 7. Phenol, 4-amino- [[webbook.nist.gov](#)]
- To cite this document: BenchChem. [Comparative FTIR Reference Guide: 4-((6,7-Dimethoxyquinolin-4-yl)amino)phenol]. BenchChem, [2026]. [Online PDF]. Available at: [<https://www.benchchem.com/product/b8224468/docs#comparative-ftir-reference-guide-4-6-7-dimethoxyquinolin-4-yl-amino-phenol>]

---

### Disclaimer & Data Validity:

The information provided in this document is for Research Use Only (RUO) and is strictly not intended for diagnostic or therapeutic procedures. While BenchChem strives to provide accurate protocols, we make no warranties, express or implied, regarding the fitness of this product for every specific experimental setup.

**Technical Support:** The protocols provided are for reference purposes. Unsure if this reagent suits your experiment?

**Need Industrial/Bulk Grade?** [Request Custom Synthesis Quote](#)

# BenchChem

Our mission is to be the trusted global source of essential and advanced chemicals, empowering scientists and researchers to drive progress in science and industry.

## Contact

Address: 3281 E Guasti Rd

Ontario, CA 91761, United States

Phone: (601) 213-4426

Email: [info@benchchem.com](mailto:info@benchchem.com)

[Contact our Ph.D. Support Team for a compatibility check](#)