

# A Comparative Guide to the Infrared Spectroscopy Analysis of Boc-Protected Spiroamines

**Author:** BenchChem Technical Support Team. **Date:** May 2026

## Compound of Interest

Compound Name: *tert-butyl N-{6-azaspiro[3.5]nonan-1-yl}carbamate*

Cat. No.: B8221923

[Get Quote](#)

## Introduction

In the landscape of modern synthetic organic chemistry, particularly in drug development and materials science, the use of protecting groups is a cornerstone of strategic molecular assembly. The tert-butoxycarbonyl (Boc) group is one of the most ubiquitous protecting groups for amines due to its stability under a wide range of conditions and its facile, clean removal under mild acidic conditions.[1][2] When the amine being protected is part of a spirocyclic system—a class of compounds known for their unique three-dimensional architecture and presence in numerous natural products—the analytical confirmation of successful protection becomes critical.[3]

Infrared (IR) spectroscopy offers a rapid, non-destructive, and highly effective method for this verification.[4][5][6] It provides direct evidence of the formation of the carbamate linkage and the disappearance of the free amine. This guide provides an in-depth analysis of the characteristic IR spectral features of Boc-protected spiroamines. It explains the causality behind the observed absorption bands, offers a comparative analysis against unprotected

amines and other protecting groups, and provides a robust experimental protocol for obtaining high-quality data.

## The Spectroscopic Signature of the N-Boc Group

The introduction of a Boc group onto a nitrogen atom fundamentally alters its vibrational properties, introducing the characteristic absorptions of a carbamate functional group. The most informative regions in the IR spectrum for confirming Boc protection are the N-H stretching, C=O stretching, and C-O stretching regions.

The key molecular vibrations of the N-Boc functional group are illustrated below. Each of these vibrations corresponds to a distinct absorption band in the IR spectrum, providing a unique fingerprint for the protecting group.

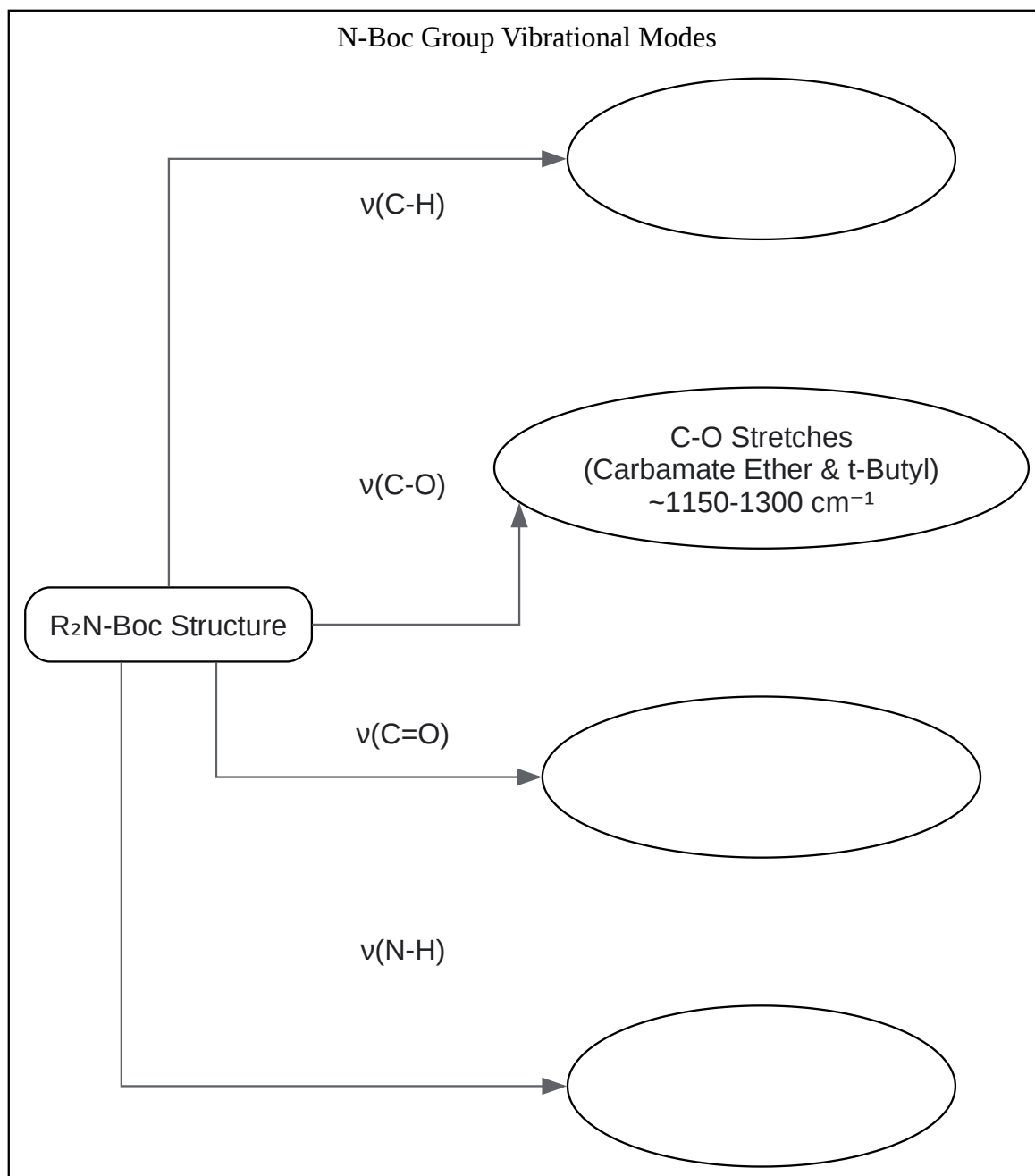

[Click to download full resolution via product page](#)

Caption: Key vibrational modes in an N-Boc protected amine.

The presence and position of these bands are definitive indicators of a successful protection reaction.

Vibrational Mode	Typical Wavenumber (cm <sup>-1</sup> )	Intensity & Characteristics	Rationale
N-H Stretch (ν <sub>N-H</sub> )	3300 - 3500	Medium, Sharp (Single Peak)	For a secondary amine (R <sub>2</sub> N-H), a single, sharp peak is expected. The Boc-protected amine is a secondary carbamate. An intense peak at 3445 cm <sup>-1</sup> has been observed for the free N-H vibration in a Boc-carbamate monomer.[7]
C=O Stretch (ν <sub>C=O</sub> )	1680 - 1720	Strong, Sharp	This is the most prominent and reliable indicator of the Boc group. Its position can be influenced by conjugation and hydrogen bonding.[8] In solid samples, hydrogen bonding can lower the frequency. [9]
C-O Stretches (ν <sub>C-O</sub> )	1150 - 1300	Strong to Medium	Carbamates exhibit strong C-O stretching bands. Often, two distinct bands can be observed corresponding to the C-O bonds of the carbamate linkage. [10]

---

C-H Bends ( $\delta$ C-H)	1365 & 1390	Medium	These two distinct bands are characteristic of the tert-butyl group due to gem-dimethyl splitting and are a strong secondary confirmation.
---------------------------	-------------	--------	--

---

## Analysis of a Boc-Protected Spiroamine: A Case Study

Spirocyclic frameworks enforce significant conformational rigidity. Unlike flexible acyclic amines, where bond angles and lengths can exist in numerous conformations, a spiro-junction locks the molecule into a more defined shape. This rigidity minimizes vibrational coupling complexities, often resulting in sharper and more clearly defined IR absorption bands.

A study involving the synthesis of bis-spirocyclic pyrrolines from an N-Boc protected precursor provides excellent experimental data for a rigid, spiro-like system.<sup>[11]</sup> The reported IR spectrum for an N-Boc protected bis-spiro-oxetane intermediate showed key absorptions that align perfectly with theoretical expectations.

Table 1: Experimental IR Data for a Boc-Protected Bis-Spirocyclic Amine Data extracted from a published synthesis of a related spirocyclic compound.<sup>[11]</sup>

Observed Wavenumber (cm <sup>-1</sup> )	Assignment	Interpretation & Significance
2970, 2938, 2873	C-H Stretch ( $\nu$ C-H)	Aliphatic C-H stretches from the spirocyclic rings and the tert-butyl group.
1690	C=O Stretch ( $\nu$ C=O)	A strong, sharp absorption confirming the presence of the carbamate carbonyl. This is the primary evidence of successful Boc protection.
1480, 1453	C-H Bend ( $\delta$ C-H)	Bending vibrations from the CH <sub>2</sub> groups within the spirocyclic framework.
1380, 1361	C-H Bend ( $\delta$ C-H)	Characteristic doublet for the tert-butyl group, providing secondary confirmation of the Boc moiety.
1287, 1243, 1168	C-O Stretch ( $\nu$ C-O)	Strong absorptions corresponding to the stretching of the C-O bonds within the carbamate group.

## Comparative IR Analysis

The power of IR spectroscopy lies in its ability to clearly distinguish between the starting material and the product. Comparing the spectrum of the Boc-protected spiroamine to logical alternatives provides an unambiguous assessment.

### Comparison 1: Unprotected Spiroamine vs. Boc-Protected Spiroamine

The most direct comparison is between the free amine and its protected counterpart. The transformation is visually striking in the IR spectrum.

Functional Group	Unprotected Spiroamine (Secondary)	Boc-Protected Spiroamine	Key Spectroscopic Change
N-H Stretch	~3300-3400 $\text{cm}^{-1}$ (Weak to Medium)	~3300-3500 $\text{cm}^{-1}$ (Medium, Sharp)	The N-H stretch remains, but its environment changes. The most dramatic change is not in the N-H region.
C=O Stretch	Absent	~1680-1720 $\text{cm}^{-1}$ (Strong)	Appearance of a strong carbonyl band is the definitive marker of reaction success.
C-N Stretch	~1020-1250 $\text{cm}^{-1}$ (Medium)	Present, but often obscured by stronger C-O bands.	The C-N stretch is less diagnostic due to its presence in a crowded region of the spectrum.
C-O Stretches	Absent	~1150-1300 $\text{cm}^{-1}$ (Strong)	Appearance of strong ether-like stretches from the carbamate.

## Comparison 2: Boc Group vs. Other Common N-Protecting Groups

While the Boc group is common, other protecting groups like Carboxybenzyl (Cbz) and Fluorenylmethyloxycarbonyl (Fmoc) are also frequently used. IR spectroscopy can readily distinguish between them, primarily due to the differences in their carbonyl environments and the presence of aromatic rings in Cbz and Fmoc.

Protecting Group	Structure	Characteristic $\nu(\text{C=O})$ ( $\text{cm}^{-1}$ )	Other Distinguishing IR Features
Boc	-CO-O-tBu	~1680-1720	C-H bends for t-butyl (~1365 & 1390 $\text{cm}^{-1}$ ). No aromatic peaks.
Cbz	-CO-O-CH <sub>2</sub> -Ph	~1690-1730	Aromatic C=C stretches (~1450-1600 $\text{cm}^{-1}$ ). Aromatic C-H stretches (>3000 $\text{cm}^{-1}$ ).
Fmoc	-CO-O-CH <sub>2</sub> -Flu	~1710-1740	Strong aromatic C=C and C-H absorptions from the large fluorenyl system.

This comparative data is invaluable for confirming the identity of a protecting group in an unknown sample or for verifying that a protecting group exchange reaction has proceeded as planned.

## Experimental Protocol: Acquiring a High-Quality FTIR Spectrum

Trustworthy data is the result of a meticulous experimental technique. The following protocol outlines the steps for obtaining a clean, interpretable IR spectrum of a Boc-protected spiroamine using a modern Attenuated Total Reflectance (ATR) FTIR spectrometer.

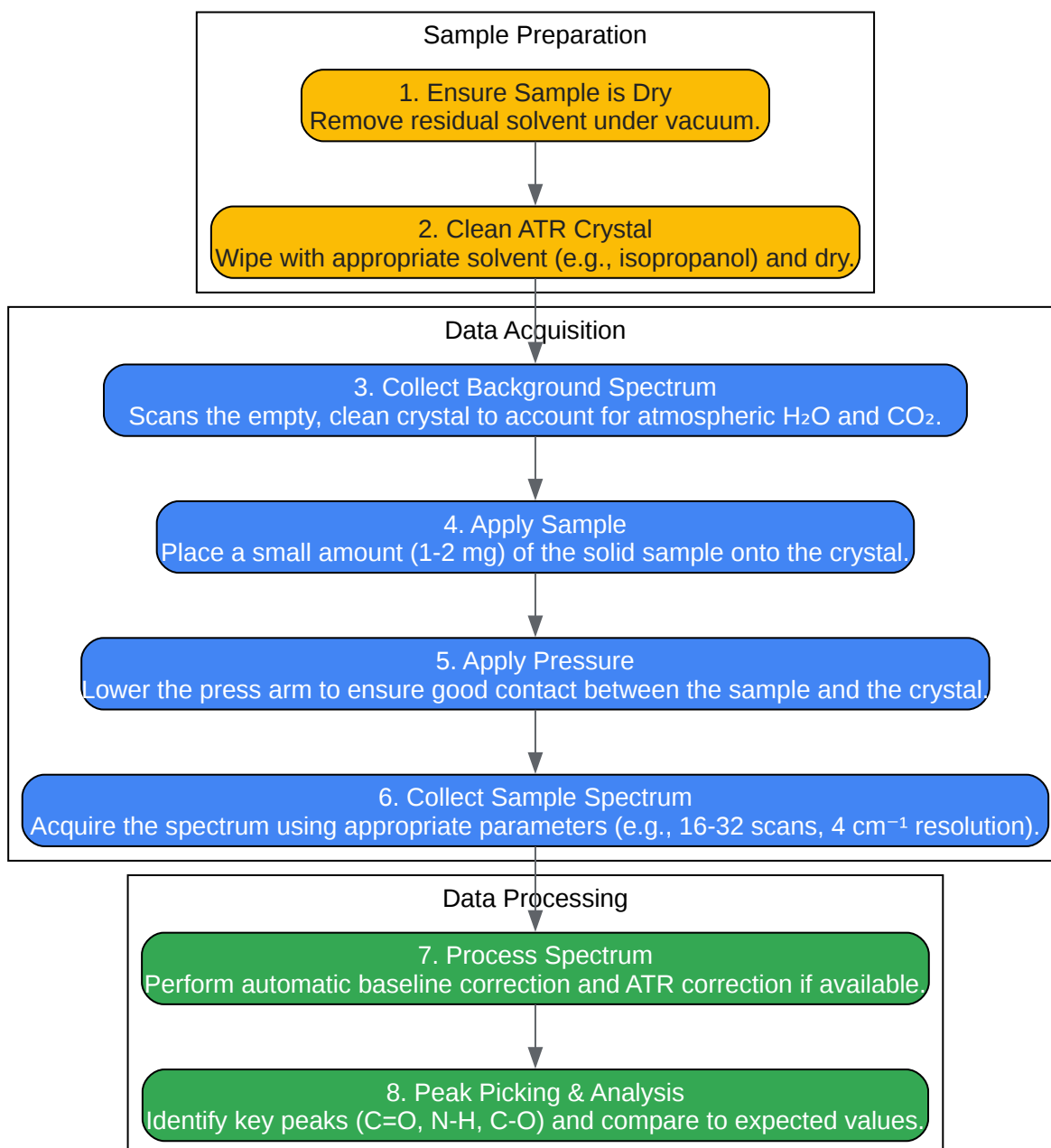

[Click to download full resolution via product page](#)

Caption: Workflow for acquiring an FTIR spectrum via ATR.

### Step-by-Step Methodology:

- Sample Preparation:
  - Causality: The sample must be free of solvents (e.g., ethyl acetate, dichloromethane) as their own strong IR absorptions (especially C=O and C-H) will obscure the analyte's spectrum. Ensure the sample is thoroughly dried under high vacuum.
- Instrument Preparation:
  - Clean the ATR crystal (typically diamond or germanium) with a lint-free wipe soaked in a volatile solvent like isopropanol. Allow it to fully evaporate.
- Background Collection:
  - Initiate a "background scan" on the instrument software. This measures the ambient atmosphere (CO<sub>2</sub>, H<sub>2</sub>O) and the crystal itself. The instrument will automatically subtract this from the sample spectrum, yielding a clean spectrum of only the compound.
- Sample Application:
  - Place a small spatula tip of the solid Boc-protected spiroamine onto the center of the ATR crystal. Only a tiny amount (1-2 mg) is needed.
- Data Collection:
  - Lower the instrument's pressure clamp to apply firm, even pressure on the sample. This ensures good contact with the ATR crystal, which is essential for a strong signal.
  - Initiate the "sample scan." Typical parameters of 16 scans at a resolution of 4 cm<sup>-1</sup> are sufficient for high-quality data.
- Analysis:
  - The resulting spectrum should show % Transmittance or Absorbance on the y-axis and Wavenumber (cm<sup>-1</sup>) on the x-axis.

- Use the software's tools to label the peaks of interest. Focus on identifying the strong carbamate C=O stretch between 1680-1720  $\text{cm}^{-1}$  as the primary confirmation of success. Corroborate this with the N-H stretch and the C-O stretches in the fingerprint region.

## Conclusion

Infrared spectroscopy is an indispensable tool for the modern chemist, and its application to the analysis of Boc-protected spiroamines is a clear demonstration of its utility. By understanding the characteristic vibrational frequencies of the N-Boc group, researchers can quickly and confidently confirm the success of their protection reactions. The key diagnostic signal is the appearance of a strong, sharp carbonyl (C=O) absorption band in the 1680-1720  $\text{cm}^{-1}$  region. The unique structural rigidity of the spirocyclic core often leads to well-resolved spectra, making this analysis particularly straightforward. By following the robust protocols and comparative data presented in this guide, researchers can ensure the integrity of their synthetic intermediates and advance their research with confidence.

## References

- University of Colorado Boulder. (n.d.). IR Spectroscopy Tutorial - Organic Chemistry. Organic Chemistry at CU Boulder. [\[Link\]](#)
- Li, Q., et al. (2018). Density Functional Theory Calculation and Raman Spectroscopy Studies of Carbamate Pesticides. PubMed. [\[Link\]](#)
- Pearson. (n.d.). Organic Chemistry Study Guide: IR Spectroscopy & Mass Spec | Practice. [\[Link\]](#)
- Fiveable. (n.d.). 1.2 Infrared (IR) spectroscopy - Organic Chemistry II. [\[Link\]](#)
- The Organic Chemistry Tutor. (2020, July 29). IR Spectroscopy - Basic Introduction. YouTube. [\[Link\]](#)
- The Organic Chemistry Tutor. (n.d.). Infrared Spectroscopy (IR). [\[Link\]](#)
- Hisatsune, I. C., & Adl, T. (1970). Infrared Spectra of Ammonium Carbamate and Deuteroammonium Carbamate. The Journal of Chemical Physics. [\[Link\]](#)

- Kim, H., et al. (2019). Unveiling the Configurational Landscape of Carbamate: Paving the Way for Designing Functional Sequence-Defined Polymers. ACS Publications. [\[Link\]](#)
- Wang, Y., et al. (2022). Spectroscopic Identification of Carbamate Formation and Synergistic Binding in Amide–CO<sub>2</sub><sup>-</sup> Complexes. The Journal of Physical Chemistry Letters. [\[Link\]](#)
- Wang, Y., et al. (2022). Spectroscopic Identification of Carbamate Formation and Synergistic Binding in Amide–CO<sub>2</sub><sup>-</sup> Complexes. ACS Publications. [\[Link\]](#)
- Hisatsune, I. C., & Adl, T. (1970). Infrared Spectra of Ammonium Carbamate and Deuteroammonium Carbamate. The Journal of Chemical Physics. [\[Link\]](#)
- Chen, J. T. (1970). Characteristic Infrared Absorption Spectra and Frequencies of Carbamate Pesticides. Journal of AOAC INTERNATIONAL. [\[Link\]](#)
- ResearchGate. (n.d.). Infrared spectra of a) carbamic acid dimer (NH<sub>2</sub>COOH)<sub>2</sub>, b) ammonium.... [\[Link\]](#)
- Wang, Y., et al. (2022). Spectroscopic Identification of Carbamate Formation and Synergistic Binding in Amide–CO<sub>2</sub><sup>-</sup> Complexes. PMC. [\[Link\]](#)
- ResearchGate. (n.d.). FT-IR spectra of N-BOC-150, N-BOC-180, and N-BOC-210 samples (a) and.... [\[Link\]](#)
- Tormyshev, V. M., et al. (2019). Bis-Spiro-Oxetane and Bis-Spiro-Tetrahydrofuran Pyrroline Nitroxide Radicals: Synthesis and Electron Spin Relaxation Studies. PMC. [\[Link\]](#)
- Deadman, B. J., et al. (2016). Selective Thermal Deprotection of N-Boc Protected Amines in Continuous Flow. Organic Process Research & Development. [\[Link\]](#)
- Der Pharma Chemica. (2015). Solvent-free, instant, ambient, n-boc protection of amines -A green, recyclable heterogenous acid catalysis. [\[Link\]](#)
- Michigan State University. (n.d.). Infrared Spectrometry. MSU Chemistry. [\[Link\]](#)
- Arshad, M., et al. (2016). Synthesis, Molecular Structure and Spectroscopic Investigations of Novel Fluorinated Spiro Heterocycles. MDPI. [\[Link\]](#)

- Organic Chemistry Portal. (n.d.). Boc-Protected Amino Groups. [[Link](#)]
- ResearchGate. (n.d.). 2-Isocyanoganilines and their mono-Boc-protected derivatives. [[Link](#)]
- Alcaide, B., et al. (2020). 2-Isocyanoganilines and their mono-Boc-protected derivatives. Organic & Biomolecular Chemistry. [[Link](#)]

### Need Custom Synthesis?

BenchChem offers custom synthesis for rare earth carbides and specific isotopic labeling.

Email: [info@benchchem.com](mailto:info@benchchem.com) or [Request Quote Online](#).

## Sources

1. [derpharmachemica.com](https://www.derpharmachemica.com) [[derpharmachemica.com](https://www.derpharmachemica.com)]
  2. [Boc-Protected Amino Groups](https://www.organic-chemistry.org) [[organic-chemistry.org](https://www.organic-chemistry.org)]
  3. [Synthesis, Molecular Structure and Spectroscopic Investigations of Novel Fluorinated Spiro Heterocycles](https://www.mdpi.com) [[mdpi.com](https://www.mdpi.com)]
  4. [orgchemboulder.com](https://www.orgchemboulder.com) [[orgchemboulder.com](https://www.orgchemboulder.com)]
  5. [fiveable.me](https://www.fiveable.me) [[fiveable.me](https://www.fiveable.me)]
  6. [solutions.bocsci.com](https://www.solutions.bocsci.com) [[solutions.bocsci.com](https://www.solutions.bocsci.com)]
  7. [Unveiling the Configurational Landscape of Carbamate: Paving the Way for Designing Functional Sequence-Defined Polymers - PMC](https://pubmed.ncbi.nlm.nih.gov/31111111/) [[pmc.ncbi.nlm.nih.gov](https://pubmed.ncbi.nlm.nih.gov/31111111/)]
  8. [youtube.com](https://www.youtube.com) [[youtube.com](https://www.youtube.com)]
  9. [academic.oup.com](https://www.academic.oup.com) [[academic.oup.com](https://www.academic.oup.com)]
  10. [Infrared Spectrometry](https://www2.chemistry.msu.edu) [[www2.chemistry.msu.edu](https://www2.chemistry.msu.edu)]
  11. [Bis-Spiro-Oxetane and Bis-Spiro-Tetrahydrofuran Pyrroline Nitroxide Radicals: Synthesis and Electron Spin Relaxation Studies - PMC](https://pubmed.ncbi.nlm.nih.gov/31111111/) [[pmc.ncbi.nlm.nih.gov](https://pubmed.ncbi.nlm.nih.gov/31111111/)]
- To cite this document: BenchChem. [A Comparative Guide to the Infrared Spectroscopy Analysis of Boc-Protected Spiroamines]. BenchChem, [2026]. [Online PDF]. Available at: [<https://www.benchchem.com/product/b8221923/docs#a-comparative-guide-to-the-infrared-spectroscopy-analysis-of-boc-protected-spiroamines>]

**Disclaimer & Data Validity:**

The information provided in this document is for Research Use Only (RUO) and is strictly not intended for diagnostic or therapeutic procedures. While BenchChem strives to provide accurate protocols, we make no warranties, express or implied, regarding the fitness of this product for every specific experimental setup.

**Technical Support:** The protocols provided are for reference purposes. Unsure if this reagent suits your experiment?

**Need Industrial/Bulk Grade?** [Request Custom Synthesis Quote](#)

## BenchChem

Our mission is to be the trusted global source of essential and advanced chemicals, empowering scientists and researchers to drive progress in science and industry.

### Contact

Address: 3281 E Guasti Rd  
Ontario, CA 91761, United States  
Phone: (601) 213-4426  
Email: [info@benchchem.com](mailto:info@benchchem.com)

[Contact our Ph.D. Support Team for a compatibility check](#)