

Process Chemistry Support Center: Scaling Up Metal-Ammonia Reductions

Author: BenchChem Technical Support Team. **Date:** April 2026

Compound of Interest

Compound Name: 4-(1,4-Cyclohexadien-1-yl)-1-butanol
Cat. No.: B8203589

[Get Quote](#)

Welcome to the Process Chemistry Technical Support Center. Dissolving metal reductions (such as the Birch and Benkeser reductions) are powerful tools for the dearomatization of arenes to 1,4-dienes. However, transitioning these reactions from the benchtop to the pilot plant introduces severe safety, engineering, and selectivity challenges.

This guide provides troubleshooting protocols, mechanistic insights, and modern alternatives to help you safely scale your reductive workflows while maintaining strict scientific integrity.

Part 1: Troubleshooting Guides & FAQs

Q1: Why does my Birch reduction scale-up suffer from over-reduction and poor regioselectivity compared to my bench-scale reactions?

The Causality: At the bench scale (e.g., 1–5 grams), magnetic stirring ensures rapid and homogeneous distribution of the solvated electrons (the deep blue lithium/ammonia solution). At the pilot scale (>50 kg), mixing times increase significantly. This creates localized concentration gradients. When the local concentration of solvated electrons is too high relative

to the proton donor (typically an alcohol), the initially formed 1,4-diene can isomerize to a conjugated 1,3-diene, which is rapidly over-reduced to a fully saturated cyclohexane derivative [1].

The Solution:

- Optimize Agitation: Transition from standard anchor stirrers to high-shear Rushton turbines to minimize the mixing time (t_{mix}).
- Controlled Addition: Feed the arene/proton donor mixture into the pre-formed Li/NH₃ solution at a strictly controlled rate, ensuring the feed rate does not exceed the mixing rate.
- In-Process Monitoring: Implement in-line ReactIR to monitor the disappearance of the aromatic C=C stretch and immediately halt the reaction before over-reduction occurs.

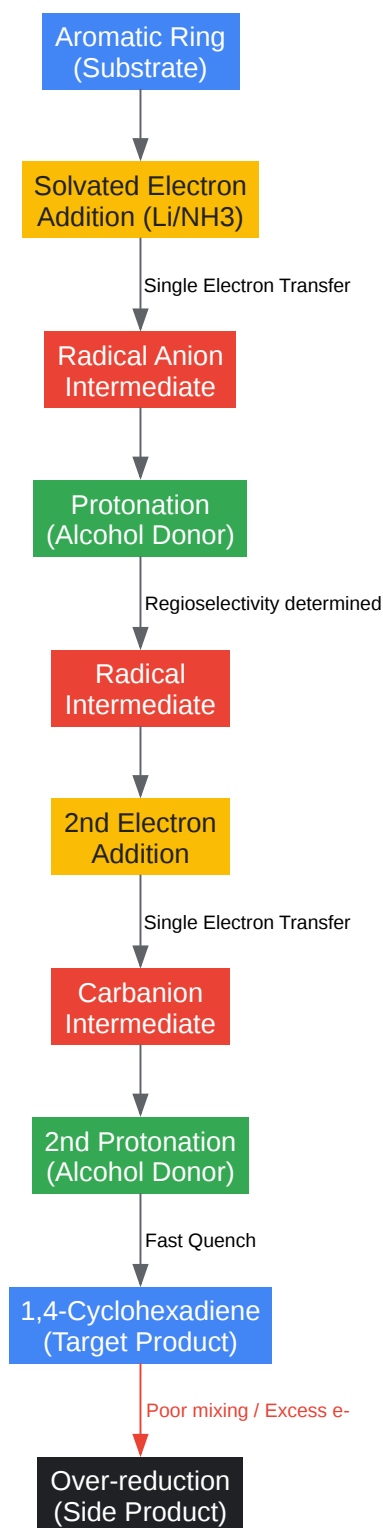

[Click to download full resolution via product page](#)

Caption: Mechanistic pathway of the Birch reduction highlighting the risk of over-reduction.

Q2: How do we safely manage the massive volume of hydrogen gas and exothermic quenching at the pilot scale?

The Causality: Quenching a Birch reduction typically involves adding a proton source (like ammonium chloride or water) to destroy unreacted alkali metal. This reaction ($2\text{Li} + 2\text{H}_2\text{O} \rightarrow 2\text{LiOH} + \text{H}_2$) is highly exothermic and rapidly liberates hydrogen gas. For context, a multikilogram synthesis of a pharmaceutical intermediate (e.g., Pfizer's sumanirole) can liberate over 2,300 liters of H_2 gas alongside massive volumes of vaporized ammonia [2]. If the heat removal capacity of the reactor condenser is exceeded, thermal runaway and over-pressurization will occur.

The Solution (Self-Validating Protocol): Use an Inverse Quench methodology combined with a continuous nitrogen sweep. By transferring the reaction mixture slowly into a large volume of the quench solution, you dictate the rate of H_2 evolution by the transfer pump speed, creating a self-limiting safety system.

Q3: What are the viable alternatives to liquid ammonia and alkali metals for multi-kilogram API synthesis?

The Causality: Handling liquid ammonia (boiling point -33°C) requires specialized cryogenic vessels, and alkali metals pose severe pyrophoric hazards. To circumvent this, process chemists are moving toward Electrochemical Birch Reductions. By replacing the alkali metal with a cathode (providing electrons) and replacing ammonia with a benign electrolyte system (e.g., LiBr in THF/water or specialized flow reactors), the safety profile is drastically improved [2, 3].

The Solution: Implement a continuous flow electrochemical Taylor vortex reactor. The high shear forces in the vortex reactor overcome the mass transfer limitations of batch electrochemistry, allowing for single-pass conversions with high productivity (>100 g/day on a benchtop footprint) [3].

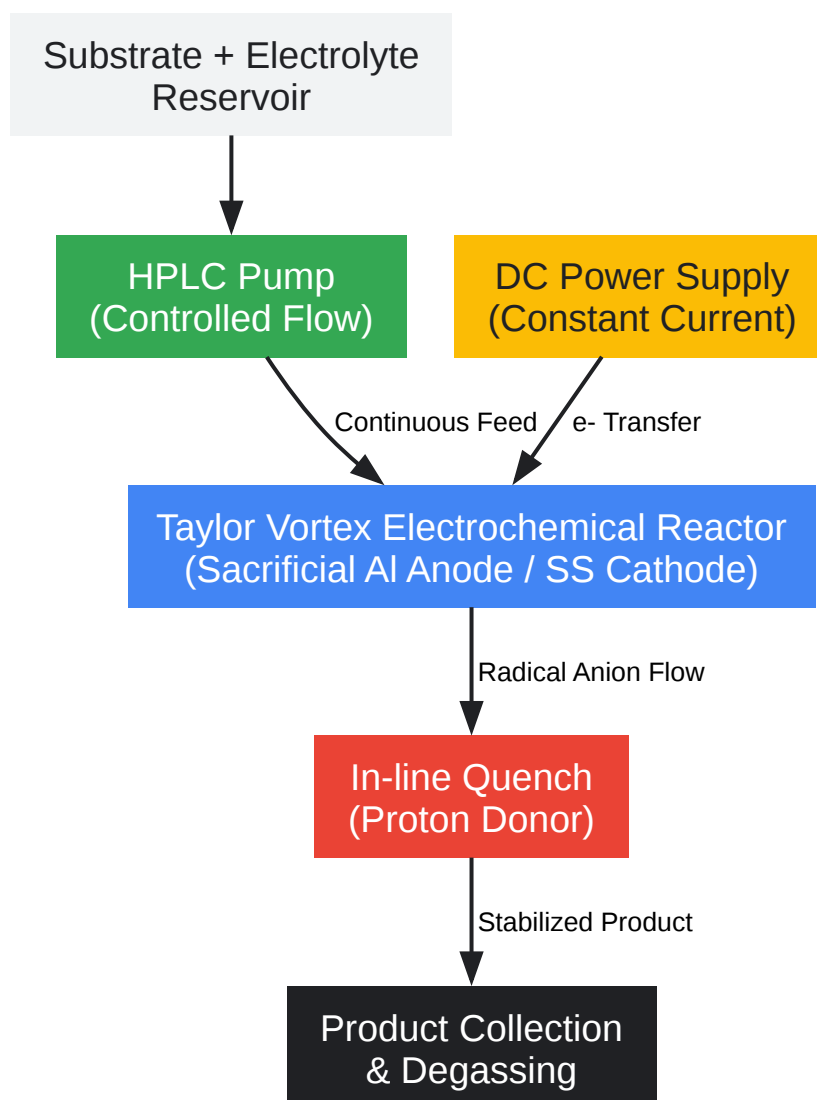

[Click to download full resolution via product page](#)

Caption: Workflow of a Continuous Flow Electrochemical Birch Reduction Setup.

Part 2: Experimental Protocols

Protocol 1: Safe Cryogenic Batch Inverse-Quench Procedure

This protocol ensures that hydrogen evolution is strictly limited by the mechanical transfer rate, preventing thermal runaway.

- Preparation of Quench Vessel: Charge a secondary reactor (Vessel B) with an aqueous solution of NH_4Cl (3.0 eq relative to Li metal) and cool to 0°C . Ensure Vessel B is equipped with a high-capacity condenser and a continuous N_2 sweep (to keep H_2 concentration below the lower explosive limit of 4%).
- Reaction Completion: Confirm the completion of the Birch reduction in the primary reactor (Vessel A) via rapid-quench GC/MS In-Process Control (IPC).
- Transfer Initiation: Pressurize Vessel A with N_2 (0.5 bar) and open the bottom transfer valve to a metered transfer pump.
- Controlled Quench: Pump the deep blue reaction mixture from Vessel A into Vessel B at a rate of 0.5 L/min.
- Thermal Monitoring: Monitor the internal temperature of Vessel B. If T_{internal} exceeds 10°C , the transfer pump must automatically pause (interlock system). The reaction is self-validating: no transfer = no heat/gas generation.
- Ammonia Evaporation: Once the transfer is complete and the blue color has fully dissipated, gradually warm Vessel B to 20°C to safely vent and scrub the residual ammonia gas through an acidic scrubber system.

Protocol 2: Single-Pass Electrochemical Birch Reduction in Flow

Adapted for a Taylor Vortex Reactor to maximize mass transfer[3].

- Electrolyte Preparation: Prepare a 0.3 M solution of the arene substrate in THF containing 0.5 M LiBr (supporting electrolyte) and 1.5 M dimethylurea (DMU, proton donor).
- Reactor Priming: Flush the Taylor vortex reactor (stainless steel inner rotor cathode, sacrificial aluminum outer tube anode) with anhydrous THF at 5 mL/min.
- Hydrodynamic Stabilization: Set the inner cylinder rotation to 1500 RPM to establish stable Taylor vortices. This ensures high mass transport to the electrode surface.
- Electrolysis: Apply a constant current density of 15 mA/cm² using a DC power supply.

- **Substrate Injection:** Switch the feed pump to the substrate/electrolyte solution at a flow rate calculated to provide a residence time of exactly 2.5 Faradays per mole of substrate.
- **Collection:** Collect the effluent in a vessel containing saturated aqueous NaHCO₃ to neutralize the DMU and extract the 1,4-diene product into an organic layer.

Part 3: Quantitative Data Comparison

When planning a scale-up, evaluating the trade-offs between traditional dissolving metal reductions and modern alternatives is critical [1].

Scale-Up Strategy	Reagents / Conditions	Yield / Selectivity	Process Mass Intensity (PMI)	Safety Profile & Cost
Traditional Batch Birch	Li metal, liquid NH ₃ , cryogenic (-33°C)	High Yield (>85%) / High Selectivity	High (due to solvent volumes)	High Risk: Pyrophoric metals, toxic gas, H ₂ evolution. Lowest reagent cost.
Electrochemical Flow	LiBr, DMU, THF, SS/Al electrodes, 20°C	Moderate Yield (~70%) / Good Selectivity	Moderate (recyclable electrolytes)	Low Risk: No liquid NH ₃ , no bulk alkali metals. High initial equipment cost.
Olefin Migration / Ketalization	Redox-neutral chemical sequence	Lower Yield (~60%) / Inherent selectivity issues	Lowest (Highly efficient)	Low Risk: Standard reactor equipment. No cryogenic requirements.

Data synthesized from multikilogram evaluations of key pharmaceutical intermediates.

Part 4: References

- Demonstration of a Multikilogram-Scale Birch Reduction and Evaluation of Alternative Synthetic Routes to a Ketalized Cyclohexene Derivative Organic Process Research & Development (2023) URL:[[Link](#)]
- Scalable and safe synthetic organic electroreduction inspired by Li-ion battery chemistry Science (2019) URL:[[Link](#)]
- High-Productivity Single-Pass Electrochemical Birch Reduction of Naphthalenes in a Continuous Flow Electrochemical Taylor Vortex Reactor Organic Process Research & Development (2021) URL:[[Link](#)]
- To cite this document: BenchChem. [Process Chemistry Support Center: Scaling Up Metal-Ammonia Reductions]. BenchChem, [2026]. [Online PDF]. Available at: [<https://www.benchchem.com/product/b8203589/docs#process-chemistry-support-center-scaling-up-metal-ammonia-reductions>]

Disclaimer & Data Validity:

The information provided in this document is for Research Use Only (RUO) and is strictly not intended for diagnostic or therapeutic procedures. While BenchChem strives to provide accurate protocols, we make no warranties, express or implied, regarding the fitness of this product for every specific experimental setup.

Technical Support: The protocols provided are for reference purposes. Unsure if this reagent suits your experiment?

Need Industrial/Bulk Grade? [Request Custom Synthesis Quote](#)

BenchChem

Our mission is to be the trusted global source of essential and advanced chemicals, empowering scientists and researchers to drive progress in science and industry.

Contact

Address: 3281 E Guasti Rd
Ontario, CA 91761, United States
Phone: (601) 213-4426
Email: info@benchchem.com

Contact our Ph.D. Support Team for a compatibility check