

Technical Support Center: Navigating the Scale-Up of BOC-Acetamide Reactions

Author: BenchChem Technical Support Team. **Date:** April 2026

Compound of Interest

Compound Name: BOC-acetamide

CAS No.: 42998-54-9

Cat. No.: B8202382

[Get Quote](#)

Welcome to the Technical Support Center for **BOC-Acetamide** Reactions. This guide is designed for researchers, scientists, and drug development professionals who are transitioning their syntheses from the bench to larger-scale production. The tert-butyloxycarbonyl (BOC) protecting group is a cornerstone of modern organic synthesis, particularly in peptide and pharmaceutical chemistry, due to its stability in various conditions and its straightforward removal under acidic conditions.^{[1][2]} However, scaling up reactions involving **BOC-acetamides** presents unique challenges that can impact yield, purity, and process safety.

This resource provides in-depth troubleshooting guides and frequently asked questions to address specific issues encountered during the scale-up of both the protection (formation) and deprotection of **BOC-acetamides**.

Part 1: Troubleshooting Guide for BOC-Acetamide Scale-Up

This section is dedicated to identifying and solving common problems that arise during the scale-up process.

Issue 1: Incomplete BOC Protection Reaction

Symptom: After the standard reaction time, analysis (e.g., TLC, LC-MS) shows a significant amount of unreacted starting amine.

Potential Causes & Solutions:

- **Insufficient Reagent Stoichiometry:** On a larger scale, mass transfer limitations can be more pronounced. What works at the gram scale may not be sufficient at the kilogram scale.
 - **Solution:** Increase the equivalents of Di-tert-butyl dicarbonate (Boc_2O). A modest increase to 1.1-1.2 equivalents is a good starting point. For less reactive amines, a larger excess may be necessary.
- **Inadequate Mixing:** In large reactors, inefficient stirring can lead to localized concentration gradients, preventing the reagents from interacting effectively.
 - **Solution:** Ensure the reactor's agitation is sufficient to maintain a homogeneous mixture. Consider the impeller design and stirring speed. For very large vessels, baffles may be necessary to improve mixing.
- **Poor Solubility:** As the scale increases, the concentration of reactants often increases, which can lead to solubility issues.
 - **Solution:** If the starting amine or Boc_2O is not fully dissolved, consider a co-solvent to improve solubility. Alternatively, a different solvent system may be required.[\[3\]](#)
- **Incorrect Base or pH:** The choice and amount of base are critical for efficient BOC protection.
 - **Solution:** Triethylamine (TEA) is a common choice, but for scale-up, consider using a weaker base like N-methylmorpholine (NMM) to minimize potential side reactions like racemization in chiral compounds.[\[4\]](#) Ensure the pH of the reaction mixture is maintained in the optimal range for the specific amine. Inorganic bases like sodium bicarbonate can also be effective.[\[5\]](#)

Issue 2: Formation of Side Products During BOC Protection

Symptom: HPLC or LC-MS analysis reveals unexpected impurities alongside the desired BOC-protected product.

Potential Causes & Solutions:

- Over-alkylation (Double BOC protection): Primary amines can sometimes react with two molecules of Boc_2O , especially with a large excess of the reagent and prolonged reaction times.
 - Solution: Carefully control the stoichiometry of Boc_2O . Add the reagent portion-wise to the reaction mixture to maintain a low instantaneous concentration. Monitor the reaction closely and stop it once the starting material is consumed.
- Urea Formation: If the reaction temperature is too high, isocyanate intermediates can form, leading to urea byproducts.
 - Solution: Maintain a controlled temperature, typically at or below room temperature. For exothermic reactions, ensure the reactor has adequate cooling capacity.
- Racemization of Chiral Centers: For chiral amines, particularly α -amino acids, the basic conditions required for BOC protection can lead to epimerization.[4]
 - Solution: Use a non-nucleophilic, sterically hindered base like Diisopropylethylamine (DIPEA) or 2,6-lutidine. Running the reaction at a lower temperature can also help to minimize racemization.[4]

Issue 3: Incomplete BOC Deprotection

Symptom: Significant amounts of the BOC-protected starting material remain after the deprotection step.

Potential Causes & Solutions:

- Insufficient Acid Strength or Concentration: The rate of BOC cleavage is highly dependent on the acid concentration.[1]
 - Solution: Increase the concentration of the acid. For example, if using 20% Trifluoroacetic acid (TFA) in Dichloromethane (DCM), consider increasing it to 50%. [1][6] Alternatively,

switch to a stronger acid system like 4M HCl in dioxane.[1]

- Steric Hindrance: Bulky groups near the BOC-protected amine can impede the approach of the acid.[1]
 - Solution: Increase the reaction time or consider a moderate increase in temperature (e.g., to 40°C).[1] Be aware that higher temperatures can also promote side reactions. Using a less sterically demanding acid may also be beneficial.[1]
- Poor Solubility at Low Temperatures: When running the reaction at 0°C to control exotherms, the starting material may not be fully dissolved.
 - Solution: Ensure complete dissolution of the substrate before adding the acid.[6] A different solvent system might be necessary to improve solubility at lower temperatures.[6]

Issue 4: Side Reactions During BOC Deprotection

Symptom: The formation of t-butylated byproducts is observed.

Potential Causes & Solutions:

- Alkylation by the t-Butyl Cation: The mechanism of acid-catalyzed BOC deprotection involves the formation of a stable tert-butyl carbocation.[1] This carbocation can alkylate nucleophilic sites on the substrate or product, such as electron-rich aromatic rings, thiols, and indoles.[7][8]
 - Solution: Add a scavenger to the reaction mixture to trap the t-butyl carbocation.[6][7] Common scavengers include triisopropylsilane (TIS), anisole, or thioanisole.[6]

Part 2: Frequently Asked Questions (FAQs)

Q1: What are the primary safety concerns when scaling up **BOC-acetamide** reactions?

A1: The main safety concerns are:

- Gas Evolution: Both the protection reaction with Boc₂O and the deprotection reaction evolve carbon dioxide gas.[9][10] On a large scale, this can lead to a significant pressure buildup if

the reactor is not properly vented. Always ensure adequate ventilation and pressure relief systems are in place.

- **Exothermic Reactions:** Both protection and deprotection reactions can be exothermic. On a large scale, the surface-area-to-volume ratio decreases, making heat dissipation less efficient.[11] This can lead to a runaway reaction. It is crucial to have a robust cooling system and to add reagents at a controlled rate.
- **Corrosive Reagents:** Strong acids like TFA and HCl used for deprotection are highly corrosive.[12] Appropriate personal protective equipment (PPE) and materials of construction for the reactor and associated equipment are essential.
- **Flammable Solvents:** Many organic solvents used in these reactions are flammable. Ensure proper grounding of equipment and use in a well-ventilated area away from ignition sources.

Q2: How do I choose the right solvent for a large-scale BOC protection?

A2: The ideal solvent should:

- Dissolve the starting amine, Boc_2O , and the base.
- Be inert to the reaction conditions.
- Have a boiling point that allows for easy removal during workup.
- Be environmentally friendly and have a good safety profile.

Commonly used solvents include tetrahydrofuran (THF), dichloromethane (DCM), and acetonitrile. For greener processes, consider alternatives like 2-methyltetrahydrofuran (2-MeTHF) or cyclopentyl methyl ether (CPME).

Q3: What are the most common methods for purifying BOC-protected products on a large scale?

A3:

- **Crystallization:** This is often the most efficient and scalable purification method.[13] If the product is a solid, screening for a suitable crystallization solvent is highly recommended.

- Extraction: Liquid-liquid extraction is used to remove water-soluble impurities and byproducts.[13]
- Distillation: For volatile products, distillation can be an effective purification technique.[13]
- Chromatography: While common in the lab, large-scale column chromatography can be expensive and time-consuming. It is typically reserved for high-value products or when other methods fail.[13]

Q4: Can I perform a BOC deprotection without using strong acids?

A4: Yes, there are alternative methods, although they may not be as universally applicable:

- Thermal Deprotection: Heating the BOC-protected amine in a suitable solvent can effect deprotection, often with no added reagents.[14] This can be advantageous for substrates with acid-sensitive functional groups.[14] Continuous flow reactors are particularly well-suited for this method.[15][16]
- Lewis Acids: Mild Lewis acids like zinc bromide can selectively remove BOC groups.[17]
- Catalytic Deprotection: Certain solid-supported acids or clays can catalyze the deprotection under milder conditions.

Part 3: Visualizations and Protocols Diagrams

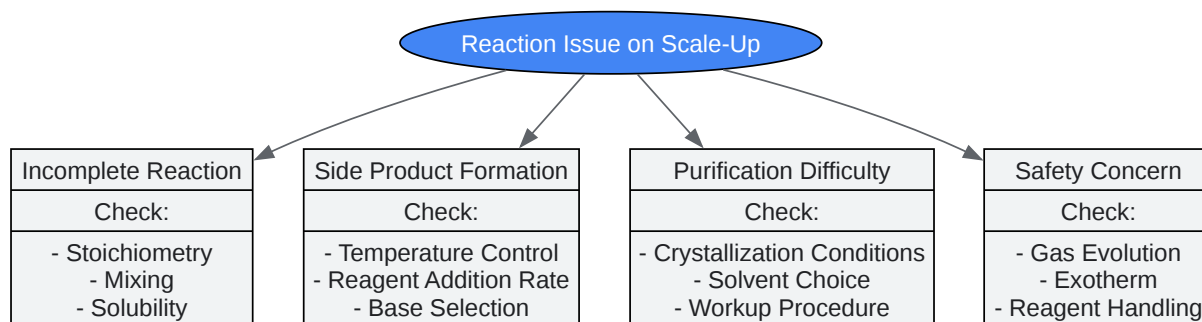
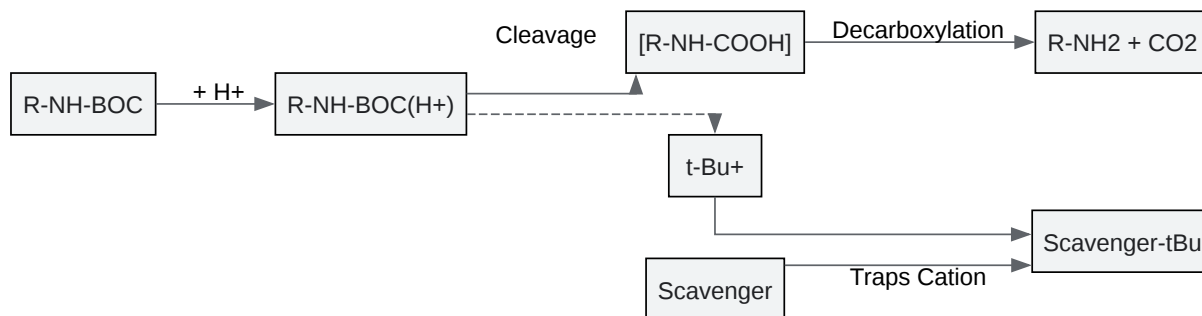

[Click to download full resolution via product page](#)

Caption: Decision tree for troubleshooting common scale-up challenges.

Data Presentation

Table 1: Comparison of Common BOC Deprotection Conditions

Reagent	Concentration	Solvent	Typical Time	Temperature	Key Considerations
Trifluoroacetic Acid (TFA)	20-50% (v/v)	Dichloromethane (DCM)	0.5 - 2 hours	0°C to RT	Highly effective but corrosive; may require scavengers. [6]
Hydrochloric Acid (HCl)	4 M	1,4-Dioxane	0.5 - 4 hours	Room Temp.	Common and cost-effective; dioxane is a process solvent to be minimized. [7] [8]
Formic Acid	Neat or in DCM	Dichloromethane (DCM)	1 - 16 hours	Room Temp.	Milder alternative, but longer reaction times may be needed. [6]
p-Toluenesulfonic Acid (pTSA)	Catalytic to Stoichiometric	DCM or Acetonitrile	10 min - 2 hours	Room Temp.	A greener alternative to TFA. [12]
Aqueous Phosphoric Acid	85 wt%	Tetrahydrofuran (THF)	4 - 8 hours	Room Temp.	Mild conditions suitable for some acid-sensitive substrates. [6]

Experimental Protocols

Protocol 1: General Procedure for Scale-Up of BOC Protection

- **Reactor Setup:** To a clean, dry, and inerted reactor equipped with an overhead stirrer, temperature probe, and addition funnel, charge the starting amine and a suitable solvent (e.g., THF).
- **Base Addition:** Add the appropriate base (e.g., triethylamine, 1.1-1.5 equivalents) to the stirred solution.
- **Boc₂O Addition:** Dissolve Di-tert-butyl dicarbonate (Boc₂O, 1.05-1.2 equivalents) in the reaction solvent and add it portion-wise to the reactor via the addition funnel, maintaining the internal temperature below 25°C.
- **Reaction Monitoring:** Stir the reaction at room temperature and monitor its progress by a suitable analytical method (e.g., TLC, HPLC, LC-MS).
- **Workup:** Once the reaction is complete, quench with water and perform a liquid-liquid extraction. Wash the organic layer with brine, dry over a suitable drying agent (e.g., anhydrous sodium sulfate), filter, and concentrate under reduced pressure.
- **Purification:** Purify the crude product by crystallization or other appropriate methods.

Protocol 2: Standard BOC Deprotection with TFA in DCM on a Larger Scale

- **Preparation:** Dissolve the BOC-protected substrate in dichloromethane (DCM) to a concentration of 0.1–0.2 M in a reactor equipped for cooling. [6]If necessary, add a scavenger (e.g., triisopropylsilane, 1.1 eq). [1]2. **Acid Addition:** Cool the solution to 0 °C using a cooling bath. Slowly add an equal volume of trifluoroacetic acid (TFA), maintaining the internal temperature below 10°C. [6]3. **Monitoring:** Stir the reaction at 0-5 °C for 30 minutes, then allow it to warm to room temperature. [6]Monitor the reaction progress until the starting material is consumed (typically 1-2 hours). [6]4. **Workup:** Upon completion, concentrate the reaction mixture under reduced pressure. To remove residual TFA, co-evaporate with a solvent like toluene (3 times). [6]The resulting amine salt can then be neutralized or used directly in the next step.

References

- BOC Sciences. (n.d.). Reaction Condition Optimization Services.
- BOC Sciences. (n.d.). Advanced Compound Analysis & Purification.
- Benchchem. (2025). Common side reactions with Boc-protected amino acids and how to avoid them.
- ACS GCI Pharmaceutical Roundtable. (n.d.). BOC Deprotection. Wordpress.
- J&K Scientific LLC. (2026, February 8). BOC Protection and Deprotection.
- Hebei Boze Chemical Co.,Ltd. (2023, July 4). BOC deprotection.
- BOC Sciences. (n.d.). Process Optimization.
- BOC Sciences. (n.d.). Acetamide Impurities.
- BOC Sciences. (n.d.). Scale-Up Solutions for Fermented Drug APIs.
- Benchchem. (2025). Technical Support Center: Stability of the Boc Protecting Group.
- Li, J., et al. (2019). Deprotection of N-Boc Groups under Continuous-Flow High-Temperature Conditions. ACS Publications.
- Sigma-Aldrich. (n.d.). BOC-ON.
- ResearchGate. (2024, July 13). Is the protecting group boc of the amino group stable at 37°C?
- Common Organic Chemistry. (n.d.). Boc Protection Mechanism (Boc2O).
- MDPI. (2022, November 19). A Brønsted Acidic Deep Eutectic Solvent for N-Boc Deprotection.
- Organic Chemistry Portal. (n.d.). Boc-Protected Amino Groups.
- NIH. (2024, April 25). Selective Thermal Deprotection of N-Boc Protected Amines in Continuous Flow. PMC.
- Semantic Scholar. (2012, May 27). A Simple and Efficient Green Method for the Deprotection of N-Boc in Various Structurally Diverse Amines under Water-mediated Catalyst-free Conditions.
- RSC Publishing. (2020, June 23). Mild deprotection of the N-tert-butyloxycarbonyl (N-Boc) group using oxalyl chloride.
- ACS Publications. (2024, April 25). Selective Thermal Deprotection of N-Boc Protected Amines in Continuous Flow | Organic Process Research & Development.
- ACS Publications. (2022, June 7). Large-Scale Amidations in Process Chemistry: Practical Considerations for Reagent Selection and Reaction Execution.
- Benchchem. (n.d.). Technical Support Center: Purification of Boc-Protected Amino Acids by Recrystallization.
- Benchchem. (2025). Technical Support Center: Optimizing Acetamide Hydrolysis.
- Benchchem. (2025). Technical Support Center: Navigating Boc Deprotection Challenges with Acid-Sensitive Substrates.

- Prime Scholars. (2021, October 27). How to deal with Scale-up challenges of Chemistry?
- PubMed. (2014). Acetamide hydrolyzing activity of Bacillus megaterium F-8 with bioremediation potential: optimization of production and reaction conditions.
- Research and Mechanism of Two-step Preparation of Acetamide from Microalgae under Hydrothermal Conditions. (n.d.).
- Mild deprotection of the N-tert-butyloxycarbonyl (N-Boc) group using oxalyl chloride. (2020, June 12).
- ResearchGate. (2023, March 17). (PDF) Synthesis and biological evaluation of substituted acetamide derivatives as potential butyrylcholinesterase inhibitors.
- Suzhou Highfine Biotech. (n.d.). Double BOC protection selective removal method.
- NIH. (2023, March 25). Synthesis and biological evaluation of substituted acetamide derivatives as potential butyrylcholinesterase inhibitors. PMC.

Need Custom Synthesis?

BenchChem offers custom synthesis for rare earth carbides and specific isotopic labeling.

Email: info@benchchem.com or [Request Quote Online](#).

Sources

- [1. pdf.benchchem.com](https://pdf.benchchem.com) [pdf.benchchem.com]
- [2. Boc-Protected Amino Groups](https://organic-chemistry.org) [organic-chemistry.org]
- [3. pdf.benchchem.com](https://pdf.benchchem.com) [pdf.benchchem.com]
- [4. pubs.acs.org](https://pubs.acs.org) [pubs.acs.org]
- [5. sigmaaldrich.com](https://sigmaaldrich.com) [sigmaaldrich.com]
- [6. pdf.benchchem.com](https://pdf.benchchem.com) [pdf.benchchem.com]
- [7. BOC Deprotection - Wordpress](https://reagents.acsgcipr.org) [reagents.acsgcipr.org]
- [8. BOC deprotection](https://ms.bzchemicals.com) [ms.bzchemicals.com]
- [9. jk-sci.com](https://jk-sci.com) [jk-sci.com]
- [10. commonorganicchemistry.com](https://commonorganicchemistry.com) [commonorganicchemistry.com]
- [11. bio-fermen.bocsci.com](https://bio-fermen.bocsci.com) [bio-fermen.bocsci.com]
- [12. A Brønsted Acidic Deep Eutectic Solvent for N-Boc Deprotection | MDPI](https://mdpi.com) [mdpi.com]
- [13. solutions.bocsci.com](https://solutions.bocsci.com) [solutions.bocsci.com]

- [14. pubs.acs.org \[pubs.acs.org\]](https://pubs.acs.org)
- [15. Selective Thermal Deprotection of N-Boc Protected Amines in Continuous Flow - PMC \[pmc.ncbi.nlm.nih.gov\]](https://pubmed.ncbi.nlm.nih.gov/)
- [16. pubs.acs.org \[pubs.acs.org\]](https://pubs.acs.org)
- [17. Double BOC protection selective removal method \[en.highfine.com\]](https://en.highfine.com)
- To cite this document: BenchChem. [Technical Support Center: Navigating the Scale-Up of BOC-Acetamide Reactions]. BenchChem, [2026]. [Online PDF]. Available at: [\[https://www.benchchem.com/product/b8202382/docs#technical-support-center-navigating-the-scale-up-of-boc-acetamide-reactions\]](https://www.benchchem.com/product/b8202382/docs#technical-support-center-navigating-the-scale-up-of-boc-acetamide-reactions)

Disclaimer & Data Validity:

The information provided in this document is for Research Use Only (RUO) and is strictly not intended for diagnostic or therapeutic procedures. While BenchChem strives to provide accurate protocols, we make no warranties, express or implied, regarding the fitness of this product for every specific experimental setup.

Technical Support: The protocols provided are for reference purposes. Unsure if this reagent suits your experiment?

Need Industrial/Bulk Grade? [Request Custom Synthesis Quote](#)

BenchChem

Our mission is to be the trusted global source of essential and advanced chemicals, empowering scientists and researchers to drive progress in science and industry.

Contact

Address: 3281 E Guasti Rd
Ontario, CA 91761, United States
Phone: (601) 213-4426
Email: info@benchchem.com

Contact our Ph.D. Support Team for a compatibility check