

Publish Comparison Guide: GC-MS Fragmentation of Methyl 5,6-Epoxyhexanoate

Author: BenchChem Technical Support Team. **Date:** April 2026

Compound of Interest

Compound Name: Methyl 4-(oxiran-2-yl)butanoate

CAS No.: 87321-81-1

Cat. No.: B8202349

[Get Quote](#)

Executive Summary

Methyl 5,6-epoxyhexanoate (MW 144.^[1]17) is a short-chain fatty acid methyl ester (FAME) featuring a terminal epoxide ring.^[1] It typically arises as an intermediate in the epoxidation of methyl 5-hexenoate or as a degradation product of longer-chain lipids.^[1]

While Electron Ionization (EI) of the methyl ester provides sufficient data for confirmation against a known standard, it often lacks the diagnostic specificity to distinguish the epoxide position from isomeric ketones or internal epoxides without ambiguity. This guide compares the standard Methyl Ester (ME) protocol against the Picolinyl Ester (PE) alternative, demonstrating why the latter is the superior choice for de novo structural characterization despite the increased sample preparation overhead.

Structural Context & Alternatives

To objectively evaluate the performance of the analytical method, we compare the target analyte against its precursor and its structural isomers.

Compound	Structure	MW	Key Challenge
Methyl 5,6-epoxyhexanoate	Terminal Epoxide (C5-C6)	144	Target. Labile epoxide ring; prone to rearrangement.[1]
Methyl 5-hexenoate	Terminal Alkene (C5=C6)	128	Precursor.[1] Mass shift of -16 Da.[1]
Methyl 4,5-epoxyhexanoate	Internal Epoxide (C4-C5)	144	Isomer.[1] Indistinguishable by molecular ion alone.
Methyl 6-oxohexanoate	Terminal Aldehyde	144	Isomer.[1] Formed by thermal rearrangement of epoxide in injector.

The Core Problem: Isomer Differentiation

Standard EI-MS of epoxy-FAMES is dominated by the carbomethoxy ions (m/z 74, 87), which confirm the ester headgroup but obscure the epoxide tail.[1] The "Alternative" method (Picolinyl derivatization) is introduced to solve this localization problem.

Experimental Methodology

Protocol A: Standard Methyl Ester Analysis (High Throughput)

- Sample Prep: Direct injection of the synthesized/extracted methyl ester.
- GC Conditions: Non-polar capillary column (e.g., DB-5ms or HP-5), 30m x 0.25mm.
- Temp Program: 50°C (1 min) → 10°C/min → 250°C.
- MS Source: Electron Ionization (70 eV), Source Temp 230°C.[1]

Protocol B: Picolinyl Ester Derivatization (High Specificity)

- Rationale: Nitrogen-containing picolinyl ring stabilizes charge, directing fragmentation along the chain to pinpoint the epoxide.
- Step 1: Hydrolysis of Methyl 5,6-epoxyhexanoate (10 mg) with 1M KOH/EtOH (60°C, 30 min).
- Step 2: Acidify (HCl), extract free acid.[1]
- Step 3: React with Thionyl Chloride (SOCl₂) to form acid chloride.
- Step 4: Add 3-hydroxymethylpyridine (3-pyridylcarbinol) to form the ester.[1]
- Analysis: Inject on GC-MS (requires higher elution temp, approx +50°C vs FAME).

Fragmentation Analysis & Diagnostic Ions[2][3][4]

A. Methyl 5,6-epoxyhexanoate (EI Spectrum)

The mass spectrum is characterized by a weak molecular ion and dominant ester fragments.

Diagnostic Ion Table:

m/z	Intensity	Origin / Mechanism	Diagnostic Value
144	< 1%	Molecular Ion [M] ⁺	Very weak; often absent.[1] Confirms MW if visible.
113	Low	[M - OCH ₃] ⁺	Loss of methoxy group.[1] Standard ester fragment.
101	Medium	[CH ₃ O-CO-(CH ₂) ₃] ⁺	Alpha-cleavage relative to the epoxide.[1] Diagnostic for epoxide position at C5.
85	Low	[M - COOCH ₃] ⁺	Loss of entire ester group.[1]
74	Base (100%)	McLafferty Rearrangement	[CH ₂ =C(OH)OCH ₃] ⁺ . Confirms methyl ester with γ-hydrogen available (C4).[1]
71	Medium	[C ₄ H ₇ O] ⁺	Rearrangement fragment (acyl) or loss of ester tail.
43	High	[C ₂ H ₃ O] ⁺	Epoxide Ring Fragment. Acetyl-like ion from the terminal epoxide cleavage.

Mechanistic Insight: The dominance of m/z 74 confirms the linear ester chain is intact up to C4. The cleavage between C4 and C5 yields the m/z 101 ion (containing the ester) and the m/z 43 ion (containing the epoxide). This 101/43 pair is the primary fingerprint for the 5,6-position.

B. Comparison with Alternatives vs. Methyl 5-Hexenoate (Alkene Precursor)[1]

- Alkene Spectrum: Base peak m/z 74. Significant ions at m/z 69 (loss of COOMe) and m/z 55 (hydrocarbon tail).
- Differentiation: The epoxide spectrum shows a mass shift (+16 Da) in the molecular ion (if seen) and the appearance of oxygenated fragments (m/z 43) replacing the hydrocarbon fragments (m/z 41/55).

vs. Picolinyl Ester (The High-Performance Alternative)[1]

- Picolinyl Spectrum:
 - Molecular Ion: Strong $[M]^+$ (Odd mass, N-rule).[1]
 - Fragmentation: Series of ions separated by 14 Da (CH_2).
 - Epoxide Marker: A distinct gap of 16 Da (Oxygen) or specific alpha-cleavage ions flanking the ring.
 - For 5,6-epoxy, significant ions would appear at atomic mass units corresponding to cleavage at C4 and C6, allowing precise localization that the Methyl Ester method cannot guarantee if isomers are present.[1]

Visualization of Fragmentation Pathways[2]

The following diagram illustrates the competing fragmentation pathways for Methyl 5,6-epoxyhexanoate under Electron Ionization.

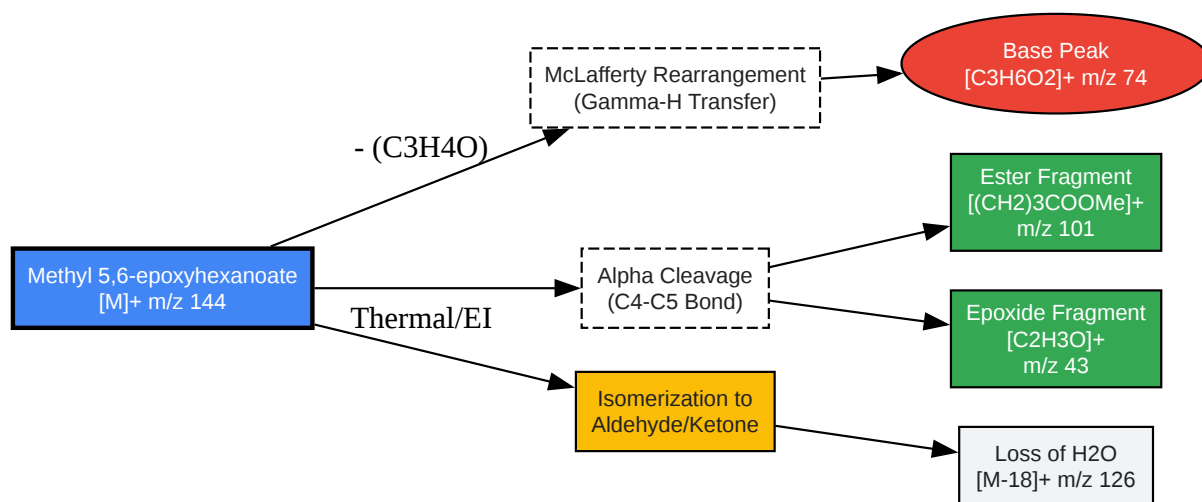

[Click to download full resolution via product page](#)

Caption: Fragmentation pathways of Methyl 5,6-epoxyhexanoate showing the dominant McLafferty rearrangement (m/z 74) and diagnostic alpha-cleavage ions (m/z 101, 43).[1]

Performance Comparison Table

Feature	Methyl Ester (Standard)	Picolinyl Ester (Alternative)	TMS Derivative (Ring Open)
Preparation Time	Fast (< 1 hr)	Slow (3-4 hrs)	Medium (1-2 hrs)
Molecular Ion	Weak / Absent	Strong	Weak
Isomer Resolution	Poor (Relies on RT)	Excellent (Mass Spec)	Good
Sensitivity	High	Medium	High
Diagnostic Ions	m/z 74, 101, 43	m/z 92, 108, + Chain	m/z 73, 147
Recommendation	Routine Screening	De Novo Identification	Quantification

References

- NIST Mass Spectrometry Data Center. (2023). Mass Spectrum of Hexanoic acid, methyl ester (C7H14O2). National Institute of Standards and Technology.[2][3] [\[Link\]](#)[1]

- Dobarganes, M. C., & Velasco, J. (2002).[1] Analysis of lipid hydroperoxides and their decomposition products. European Journal of Lipid Science and Technology. [\[Link\]](#)
- Christie, W. W. (1998). Gas Chromatography and Lipids: A Practical Guide. The Oily Press. (Chapter on Structural Analysis of Fatty Acids). [\[Link\]](#)[1]
- NIST Webbook. (2023). Mass Spectrum of 1,2-Epoxyhexane (Oxirane, butyl-). [\[Link\]](#)[1]

Need Custom Synthesis?

BenchChem offers custom synthesis for rare earth carbides and specific isotopic labeling.

Email: info@benchchem.com or [Request Quote Online](#).

Sources

- [1. Epoxidation of Methyl Esters as Valuable Biomolecules: Monitoring of Reaction - PMC \[pmc.ncbi.nlm.nih.gov\]](#)
- [2. Oxirane, butyl- \[webbook.nist.gov\]](#)
- [3. Oxirane, butyl- \[webbook.nist.gov\]](#)
- To cite this document: BenchChem. [Publish Comparison Guide: GC-MS Fragmentation of Methyl 5,6-Epoxyhexanoate]. BenchChem, [2026]. [Online PDF]. Available at: [\[https://www.benchchem.com/product/b8202349/docs#publish-comparison-guide-gc-ms-fragmentation-of-methyl-5-6-epoxyhexanoate\]](https://www.benchchem.com/product/b8202349/docs#publish-comparison-guide-gc-ms-fragmentation-of-methyl-5-6-epoxyhexanoate)

Disclaimer & Data Validity:

The information provided in this document is for Research Use Only (RUO) and is strictly not intended for diagnostic or therapeutic procedures. While BenchChem strives to provide accurate protocols, we make no warranties, express or implied, regarding the fitness of this product for every specific experimental setup.

Technical Support: The protocols provided are for reference purposes. Unsure if this reagent suits your experiment?

Need Industrial/Bulk Grade? [Request Custom Synthesis Quote](#)

BenchChem

Our mission is to be the trusted global source of essential and advanced chemicals, empowering scientists and researchers to drive progress in science and industry.

Contact

Address: 3281 E Guasti Rd

Ontario, CA 91761, United States

Phone: (601) 213-4426

Email: info@benchchem.com

[Contact our Ph.D. Support Team for a compatibility check](#)