

LY2880070 as a Chemosensitization Agent: A Technical Guide

Author: BenchChem Technical Support Team. **Date:** April 2026

Compound of Interest

Compound Name:	LY2880070
CAS No.:	1375637-35-6
Cat. No.:	B8196068

[Get Quote](#)

For Researchers, Scientists, and Drug Development Professionals

Abstract

LY2880070 is an orally bioavailable, selective, and ATP-competitive inhibitor of checkpoint kinase 1 (Chk1) that has shown potential as a chemosensitization agent.^[1] By abrogating the DNA damage repair process, **LY2880070** may enhance the cytotoxicity of DNA-damaging chemotherapeutic agents, representing a promising strategy to overcome tumor cell resistance. ^[1] This technical guide provides a comprehensive overview of the preclinical and clinical data on **LY2880070** as a chemosensitizing agent, with a focus on its combination with gemcitabine. It includes a summary of its mechanism of action, quantitative data from in vitro and clinical studies, detailed experimental protocols, and visualizations of the relevant signaling pathways and experimental workflows.

Introduction: The Rationale for Chk1 Inhibition in Chemosensitization

Checkpoint kinase 1 (Chk1) is a critical serine/threonine kinase in the DNA damage response (DDR) pathway. In response to DNA damage, Chk1 is activated and orchestrates cell cycle arrest, allowing time for DNA repair before entry into mitosis. Many cancer cells, particularly those with p53 mutations, are heavily reliant on the Chk1-mediated checkpoint for survival, especially when challenged with DNA-damaging agents.

By inhibiting Chk1, **LY2880070** prevents this crucial cell cycle arrest, forcing cancer cells with damaged DNA to enter mitosis prematurely. This leads to mitotic catastrophe and subsequent apoptosis. This mechanism of action suggests that **LY2880070** could potentiate the anti-tumor activity of various chemotherapeutic drugs that induce DNA damage, effectively sensitizing cancer cells to lower doses of these agents and potentially overcoming resistance.

Mechanism of Action: The Chk1 Signaling Pathway

LY2880070 selectively binds to and inhibits the activity of Chk1.^[1] In the presence of DNA damage induced by chemotherapy (e.g., gemcitabine), the ATR (Ataxia Telangiectasia and Rad3-related) kinase is activated, which in turn phosphorylates and activates Chk1. Activated Chk1 then phosphorylates and inactivates Cdc25 phosphatases, leading to the accumulation of inhibitory phosphorylation on cyclin-dependent kinases (CDKs) and subsequent cell cycle arrest. By inhibiting Chk1, **LY2880070** allows Cdc25 to remain active, leading to CDK activation and premature mitotic entry despite the presence of DNA damage.

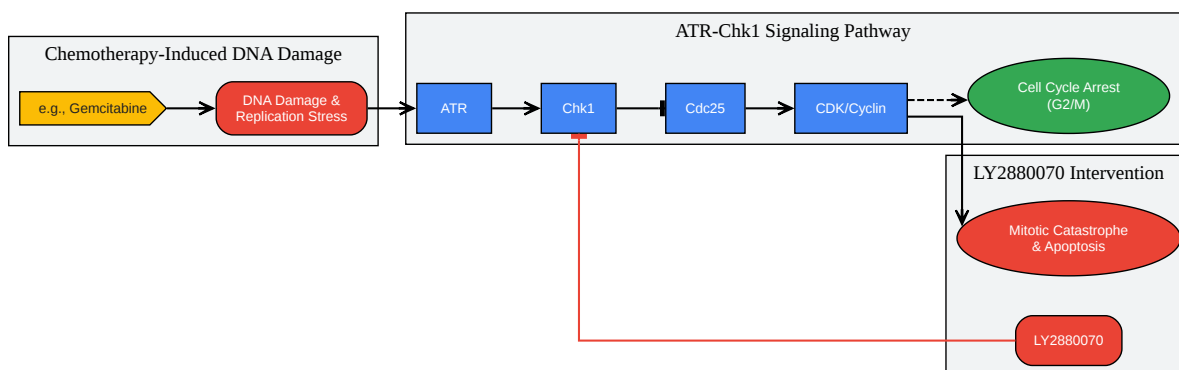

[Click to download full resolution via product page](#)

Figure 1: Mechanism of Action of **LY2880070** in Chemosensitization.

Quantitative Data

In Vitro Efficacy: Patient-Derived Pancreatic Cancer Organoids

A study on patient-derived organoids from a phase I expansion cohort of the NCT02632448 trial provided in vitro data on the combination of **LY2880070** and gemcitabine in pancreatic ductal adenocarcinoma (PDAC).^[2]

Organoid Line	Drug	IC50 (nM)
PT-4	Gemcitabine	15
LY2880070		38
PT-6	Gemcitabine	56
LY2880070		91

Table 1: IC50 values for gemcitabine and **LY2880070** in patient-derived PDAC organoids.[2]

The study also demonstrated synergistic cell death with the combination treatment in these organoid models.[2][3]

Clinical Efficacy: Phase Ib/IIa Trial (NCT02632448)

The NCT02632448 trial was a multi-part study evaluating **LY2880070** as a monotherapy and in combination with gemcitabine in patients with advanced or metastatic solid tumors.[4]

Cancer Type	Treatment Regimen	Best Overall Response	Number of Patients
Ovarian Cancer	LY2880070 + Gemcitabine	Confirmed Partial Response	1[5][6]
Various Solid Tumors	LY2880070 + Gemcitabine	Stable Disease (≥ 6 cycles)	2[6]
Pancreatic Ductal Adenocarcinoma (Expansion Cohort)	LY2880070 (50 mg BID) + Gemcitabine (100 mg/m ²)	No Objective Radiological Responses	11[2][7][8]

Table 2: Summary of clinical responses from the NCT02632448 trial.[2][5][6][7][8]

While the combination of **LY2880070** and low-dose gemcitabine was well-tolerated, it did not demonstrate clinical activity in a heavily pretreated metastatic PDAC cohort.[2][7][8] However, a confirmed partial response was observed in a patient with ovarian cancer in the dose-escalation phase of the trial.[5][6]

Experimental Protocols

Clinical Trial Protocol (NCT02632448 - PDAC Expansion Cohort)

- Study Design: Phase I expansion cohort study for patients with previously treated metastatic PDAC.[2][7]
- Treatment Regimen:

- Gemcitabine: 100 mg/m² intravenously on days 1, 8, and 15 of each 21-day cycle.[2][7]
- **LY2880070**: 50 mg orally twice daily on days 2-6, 9-13, and 16-20 of each 21-day cycle.[2][7]
- Patient Population: 11 patients with metastatic PDAC were enrolled between August 27, 2020, and July 30, 2021.[2][7]
- Correlative Studies: Pre-treatment tumor biopsies were obtained for the generation of organoid cultures for drug sensitivity testing and biomarker analyses.[2][7]

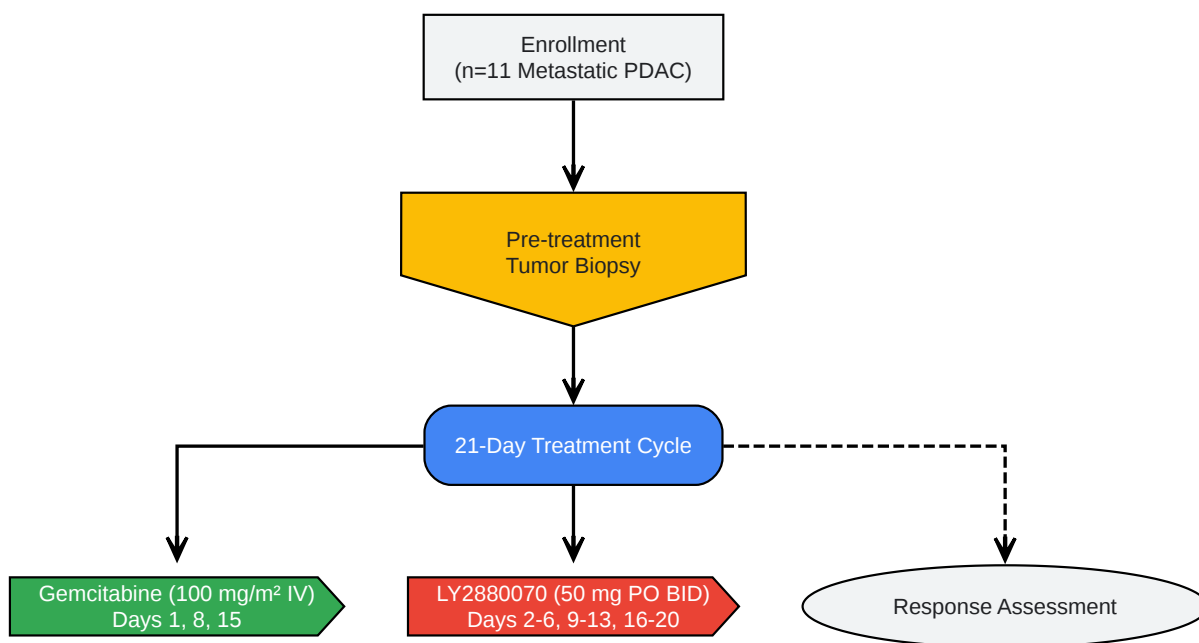

[Click to download full resolution via product page](#)

Figure 2: Experimental workflow for the NCT02632448 PDAC expansion cohort.

Immunoblotting for Pharmacodynamic Biomarkers

- Objective: To assess markers of DNA damage and replication stress in patient-derived organoids.
- Procedure:

- Organoid cultures were exposed to DMSO (control), gemcitabine, **LY2880070**, or a combination of both for 24 hours.[2]
- Lysates were generated from the treated organoids.[2]
- Western blotting was performed to detect the following biomarkers:
 - γ -H2AX: A marker of DNA double-strand breaks.
 - pKAP1, pRPA32: Markers of replication stress.[2]
- Results: The combination of gemcitabine and **LY2880070** markedly enhanced the levels of these DNA damage and replication stress markers compared to either agent alone.[2]

Replication Fork Stability Assay

- Objective: To determine the effect of **LY2880070** and gemcitabine on the stability of DNA replication forks.
- Procedure:
 - Patient-derived organoids (PT-4 and PT-6) were treated with gemcitabine and **LY2880070** at specific concentrations (PT-4: 30 nM gemcitabine + 15 nM **LY2880070**; PT-6: 80 nM gemcitabine + 50 nM **LY2880070**).[2]
 - A DNA fiber assay was performed to visualize and measure the length of newly synthesized DNA strands.
 - Replication fork degradation was assessed by measuring the ratio of the lengths of two sequentially incorporated nucleotide analogs.
- Results: The combination treatment led to increased replication fork instability.[2]

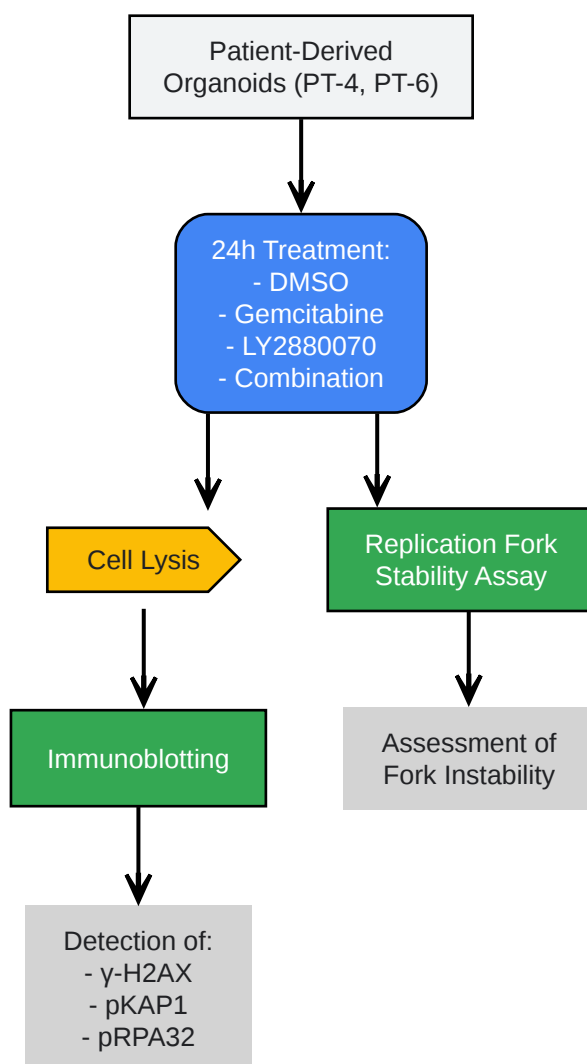

[Click to download full resolution via product page](#)

Figure 3: Workflow for pharmacodynamic biomarker analysis.

Discussion and Future Directions

The available data suggest that **LY2880070** effectively inhibits Chk1 and can synergize with gemcitabine to induce DNA damage and replication stress in preclinical models of pancreatic cancer. However, this promising *in vitro* activity did not translate into objective clinical responses in a small cohort of heavily pretreated metastatic PDAC patients. This discrepancy highlights the challenges of translating preclinical findings to the clinical setting and may be due to factors such as tumor heterogeneity, the tumor microenvironment, or insufficient drug exposure at the tumor site.

The observation of a partial response in an ovarian cancer patient suggests that the chemosensitizing potential of **LY2880070** may be context-dependent and that patient selection will be crucial for future clinical development. Further investigation is warranted to identify predictive biomarkers that can identify patient populations most likely to benefit from Chk1 inhibition. Additionally, exploring combinations of **LY2880070** with other classes of DNA-damaging agents and in different tumor types could unveil its full therapeutic potential. While preclinical xenograft studies have been mentioned to project effective human doses, the public availability of this data is limited.[5]

Conclusion

LY2880070 is a potent Chk1 inhibitor with a clear mechanism of action for chemosensitization. While clinical efficacy in combination with gemcitabine has been modest in advanced pancreatic cancer, the preclinical rationale remains strong, and signals of activity in other tumor types have been observed. Future research should focus on biomarker-driven patient selection and the exploration of novel combination strategies to optimize the clinical application of **LY2880070** as a chemosensitization agent.

Need Custom Synthesis?

BenchChem offers custom synthesis for rare earth carbides and specific isotopic labeling.

Email: info@benchchem.com or [Request Quote Online](#).

References

- [1. Facebook \[cancer.gov\]](#)
- [2. A Phase 1 Expansion Cohort Study Evaluating the Safety and Efficacy of the CHK1 Inhibitor LY2880070 with Low-Dose Gemcitabine in Metastatic Pancreatic Adenocarcinoma Patients - PMC \[pmc.ncbi.nlm.nih.gov\]](#)
- [3. researchgate.net \[researchgate.net\]](#)
- [4. ClinicalTrials.gov \[clinicaltrials.gov\]](#)
- [5. researchgate.net \[researchgate.net\]](#)
- [6. ascopubs.org \[ascopubs.org\]](#)

- [7. A Phase I Expansion Cohort Study Evaluating the Safety and Efficacy of the CHK1 Inhibitor LY2880070 with Low-dose Gemcitabine in Patients with Metastatic Pancreatic Adenocarcinoma - PubMed \[pubmed.ncbi.nlm.nih.gov\]](#)
- [8. researchgate.net \[researchgate.net\]](#)
- To cite this document: BenchChem. [LY2880070 as a Chemosensitization Agent: A Technical Guide]. BenchChem, [2026]. [Online PDF]. Available at: [\[https://www.benchchem.com/product/b8196068/docs#ly2880070-as-a-chemosensitization-agent-a-technical-guide\]](https://www.benchchem.com/product/b8196068/docs#ly2880070-as-a-chemosensitization-agent-a-technical-guide)

Disclaimer & Data Validity:

The information provided in this document is for Research Use Only (RUO) and is strictly not intended for diagnostic or therapeutic procedures. While BenchChem strives to provide accurate protocols, we make no warranties, express or implied, regarding the fitness of this product for every specific experimental setup.

Technical Support: The protocols provided are for reference purposes. Unsure if this reagent suits your experiment?

Need Industrial/Bulk Grade? [Request Custom Synthesis Quote](#)

BenchChem

Our mission is to be the trusted global source of essential and advanced chemicals, empowering scientists and researchers to drive progress in science and industry.

Contact

Address: 3281 E Guasti Rd
Ontario, CA 91761, United States
Phone: (601) 213-4426
Email: info@benchchem.com

[Contact our Ph.D. Support Team for a compatibility check](#)

