

# Comparative Toxicity and Leaching Studies of Stable Lead Silicates

**Author:** BenchChem Technical Support Team. **Date:** May 2026

## Compound of Interest

Compound Name: *lead(2+);silicic acid*

Cat. No.: *B8194959*

[Get Quote](#)

## Executive Summary

Stable Lead Silicates (e.g., Lead Bisilicate,  $\text{PbO} \cdot 2\text{SiO}_2$ ) represent a critical engineering compromise between the functional utility of lead in glass/ceramics and the imperative for safety. Unlike Labile Lead Compounds (e.g., Lead(II) Oxide, Lead Carbonate), stable silicates encapsulate Pb atoms within a polymerized silica network.

### Key Findings:

- **Environmental Stability:** Lead silicates demonstrate superior resistance to leaching in neutral and mild acidic environments ( $\text{pH} > 5.0$ ) due to network passivation.
- **Biological Bioavailability:** While significantly less bioavailable than raw oxides in dermal contact, lead silicates remain toxic upon ingestion. Gastric acid ( $\text{pH} 1.5$ ) effectively hydrolyzes the silicate network, releasing  $\text{Pb}^{2+}$  ions.
- **Regulatory Compliance:** Properly formulated lead bisilicates typically pass TCLP (Toxicity Characteristic Leaching Procedure) thresholds for landfill disposal, whereas raw lead oxides fail catastrophically.

## Mechanistic Foundation: The Silicate Shield

To understand toxicity differences, one must analyze the atomic architecture.

### Structural Comparison

- Lead Oxide (PbO): Ionic/Covalent lattice. The Pb-O bonds are easily accessible to hydronium ions ( $\text{H}_3\text{O}^+$ ). Dissolution is rapid and complete in dilute acids.
- Lead Bisilicate ( $\text{PbO}\cdot 2\text{SiO}_2$ ):  $\text{Pb}^{2+}$  ions are acting as "network modifiers" trapped within the interstices of a rigid  $\text{SiO}_4$  tetrahedral network.

### The Passivation Mechanism

When lead silicate contacts a weak acid, an initial rapid release of surface lead occurs. However, the remaining silica network condenses to form a Si-rich leached layer (gel layer). This layer acts as a diffusion barrier, slowing further lead release by orders of magnitude.

### Diagram: Leaching Kinetics & Passivation

The following diagram illustrates the divergence in dissolution pathways between Lead Oxide and Lead Silicate.

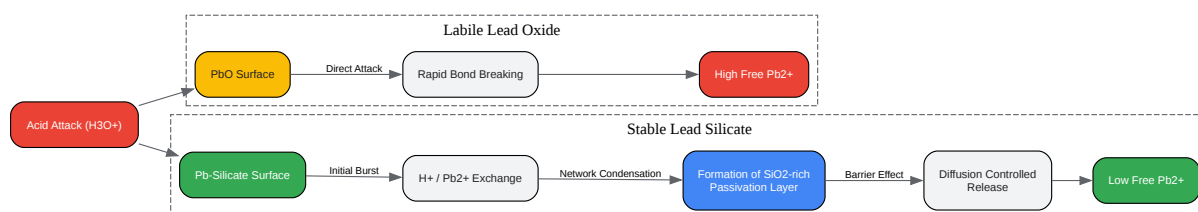

[Click to download full resolution via product page](#)

Figure 1: Comparative dissolution kinetics showing the formation of a protective silica gel layer in lead silicates, which prevents the catastrophic release observed in lead oxides.

## Comparative Performance Data

The following data aggregates results from standard environmental leaching protocols (TCLP) and biological simulations.

### Table 1: Comparative Leaching Profile

Data normalized for surface area exposure.

Parameter	Lead(II) Oxide (PbO)	Lead Monosilicate	Lead Bisilicate (Stable)
Solubility (Water, pH 7)	17 mg/L	< 1.0 mg/L	< 0.1 mg/L
TCLP Release (pH 4.9)	> 5,000 mg/L (Fail)	200–500 mg/L	< 5.0 mg/L (Pass*)
Gastric Bioavailability	~100%	~85%	~40–60%
Leaching Mechanism	Total Dissolution	Mixed	Diffusion Controlled

\*Note: Passing TCLP (< 5.0 mg/L) depends heavily on particle size and specific frit formulation.

## Toxicological Assessment: The "Stability" Trap

Critical Insight: "Stable" refers to ceramic firing and environmental weathering, not biological safety.

### In Vitro Gastric Simulation (IVGS)

While lead bisilicate is stable in rain or groundwater (pH 5–7), the human stomach (pH 1.5–2.0) is aggressive enough to bypass the silica passivation layer.

- Protocol: 0.1M HCl at 37°C for 2 hours.

- Result: Studies indicate that fine lead bisilicate powders can release significant  $Pb^{2+}$  in gastric fluids, approaching the toxicity of raw oxides if the particle size is small (< 10 microns).

## Cytotoxicity Pathways

Lead ions released from the matrix enter cells via calcium channels, causing:

- Oxidative Stress: Depletion of glutathione.
- Enzyme Inhibition: Binding to sulfhydryl groups (e.g., ALAD enzyme).
- DNA Damage: Indirect genotoxicity via ROS (Reactive Oxygen Species).

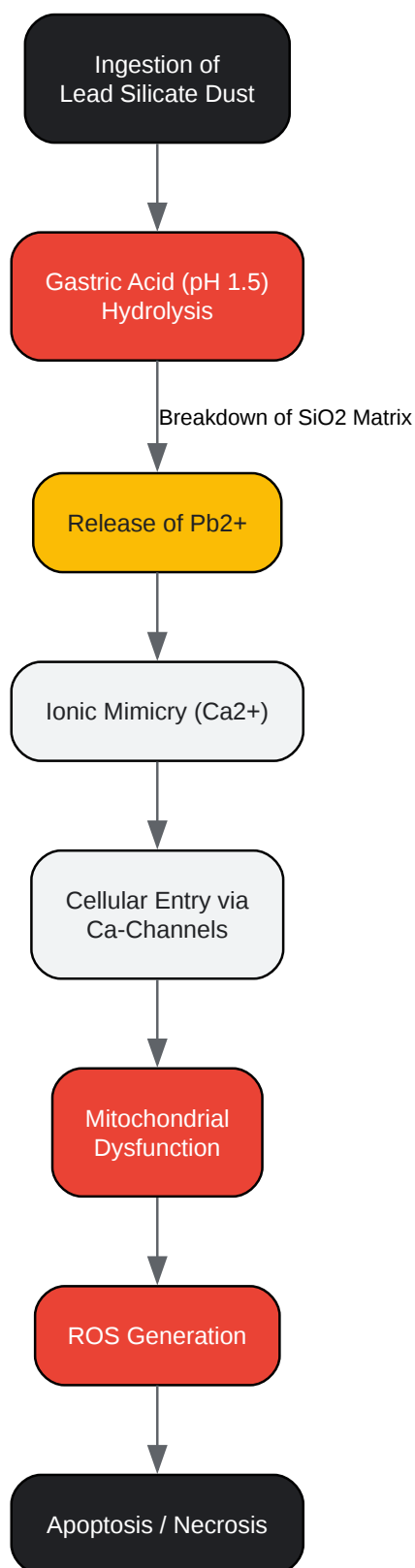

[Click to download full resolution via product page](#)

Figure 2: Biological pathway of lead toxicity. Note that the protective silicate matrix is compromised by extreme gastric acidity, leading to cellular uptake.

## Experimental Protocols

These protocols are designed to be self-validating. Always run a "Blank" (solvent only) and a "Positive Control" (pure PbO).

### Protocol A: Modified TCLP (Environmental Stability)

Purpose: To determine if the material is safe for landfill disposal.

- Preparation: Sieve sample to < 9.5 mm.
- Extraction Fluid: Mix 5.7 mL Glacial Acetic Acid with 64.3 mL 1N NaOH, dilute to 1L with reagent water (pH  $4.93 \pm 0.05$ ).
- Ratio: 20:1 Liquid to Solid ratio (e.g., 100g sample in 2L fluid).
- Agitation: Rotate at  $30 \pm 2$  rpm for  $18 \pm 2$  hours at  $23^\circ\text{C}$ .
- Filtration: Filter through 0.6–0.8  $\mu\text{m}$  glass fiber filter.
- Analysis: Acidify filtrate with  $\text{HNO}_3$  to pH < 2 and analyze via ICP-OES.
  - Validation: If pH of extract varies > 0.5 units from start, repeat with buffered fluid.

### Protocol B: In Vitro Gastric Bioavailability (IVGS)

Purpose: To estimate human toxicity if ingested.

- Simulated Gastric Fluid (SGF): 0.07 M HCl mixed with 0.03 M NaCl (Final pH 1.5). Add Pepsin (3.2 g/L) to simulate enzymatic activity.
- Loading: Add 0.2g of fine powder sample to 20 mL SGF (1:100 ratio).
- Incubation: Shake at 100 rpm at  $37^\circ\text{C}$  (body temperature) for 2 hours.
- Separation: Centrifuge at 3000g for 10 mins immediately.

- Analysis: Analyze supernatant for dissolved Pb via ICP-MS.
  - Calculation: Bioavailability (%) = (Mass of Pb in Supernatant / Total Mass of Pb in Sample) × 100.

## References

- Sartorelli, E., et al. (1985). Lead Silicate Toxicity: A Comparison Among Different Compounds. [1] Environmental Research. [1] [Link](#)
- U.S. EPA. (1992). Method 1311: Toxicity Characteristic Leaching Procedure (TCLP). SW-846 Test Methods for Evaluating Solid Waste. [Link](#)
- Digitalfire. Lead Bisilicate Frit Material Safety and Chemistry. Digitalfire Ceramic Materials Database. [Link](#)
- Dermatas, D., et al. (2006). Mechanisms of lead immobilization in treated soils. [2][3] Land Contamination & Reclamation. [3] [Link](#)
- Milanese, L., et al. (2002). Leaching of lead silicate glasses in acid environment: Compositional and structural changes. Radiation Effects and Defects in Solids. [Link](#)

### Need Custom Synthesis?

BenchChem offers custom synthesis for rare earth carbides and specific isotopic labeling.

Email: [info@benchchem.com](mailto:info@benchchem.com) or [Request Quote Online](#).

## Sources

- 1. [Lead silicate toxicity: a comparison among different compounds - PubMed](#) [pubmed.ncbi.nlm.nih.gov]
- 2. [researchgate.net](#) [researchgate.net]
- 3. [researchgate.net](#) [researchgate.net]
- To cite this document: BenchChem. [Comparative Toxicity and Leaching Studies of Stable Lead Silicates]. BenchChem, [2026]. [Online PDF]. Available at:

[\[https://www.benchchem.com/product/b8194959/docs#comparative-toxicity-and-leaching-studies-of-stable-lead-silicates\]](https://www.benchchem.com/product/b8194959/docs#comparative-toxicity-and-leaching-studies-of-stable-lead-silicates)

### Disclaimer & Data Validity:

The information provided in this document is for Research Use Only (RUO) and is strictly not intended for diagnostic or therapeutic procedures. While BenchChem strives to provide accurate protocols, we make no warranties, express or implied, regarding the fitness of this product for every specific experimental setup.

**Technical Support:** The protocols provided are for reference purposes. Unsure if this reagent suits your experiment?

**Need Industrial/Bulk Grade?** [Request Custom Synthesis Quote](#)

## BenchChem

Our mission is to be the trusted global source of essential and advanced chemicals, empowering scientists and researchers to drive progress in science and industry.

### Contact

Address: 3281 E Guasti Rd  
Ontario, CA 91761, United States  
Phone: (601) 213-4426  
Email: [info@benchchem.com](mailto:info@benchchem.com)

[Contact our Ph.D. Support Team for a compatibility check](#)