

# Technical Support Center: RMC-0331 In Vivo Studies

**Author:** BenchChem Technical Support Team. **Date:** April 2026

## Compound of Interest

Compound Name: RMC-0331

Cat. No.: B8192633

[Get Quote](#)

This technical support center provides troubleshooting guides and frequently asked questions (FAQs) for researchers using the SOS1 inhibitor **RMC-0331** in in vivo models. The information is intended for scientists and drug development professionals to help mitigate potential toxicity and ensure successful experimental outcomes.

## Frequently Asked Questions (FAQs)

Q1: What is **RMC-0331** and what is its mechanism of action?

A1: **RMC-0331** is a potent, selective, and orally bioavailable small molecule inhibitor of Son of Sevenless 1 (SOS1).[1][2] SOS1 is a guanine nucleotide exchange factor (GEF) that plays a critical role in activating RAS proteins by promoting the exchange of GDP for GTP.[1] **RMC-0331** disrupts the interaction between SOS1 and KRAS, thereby blocking this activation step and inhibiting downstream RAS signaling pathways, which are often hyperactivated in cancer.  
[1]

Q2: What is the typical dose range for **RMC-0331** in mouse models?

A2: Preclinical studies in immunocompetent mice have reported using **RMC-0331** at doses ranging from 100 to 250 mg/kg, administered orally once daily (p.o. qd).[2] This dosage has

been shown to elicit anti-tumor activity in SHP2-mutant models.[2]

Q3: Is there any published information on the in vivo toxicity of **RMC-0331**?

A3: As of late 2025, detailed public information specifically on the in vivo toxicity profile of **RMC-0331** is limited. However, studies on other selective SOS1 inhibitors, such as BI-3406, have suggested that pharmacological inhibition of SOS1 is generally well-tolerated in preclinical mouse models, with no significant systemic toxicity or impact on animal weight and viability observed. This is in contrast to the lethality reported with genetic ablation of SOS1 in some contexts, suggesting a potential therapeutic window for transient pharmacological inhibition.

Q4: What is the primary intended application of **RMC-0331** in research?

A4: **RMC-0331** is primarily used as an in vivo tool compound to study the effects of SOS1 inhibition on RAS-driven biological processes, particularly in the context of cancer research.[1] It is utilized to investigate the therapeutic potential of targeting the SOS1-RAS interaction, both as a monotherapy and in combination with other targeted agents.

## Troubleshooting Guide: Mitigating In Vivo Toxicity

This guide addresses potential issues that may arise during in vivo experiments with **RMC-0331** and offers strategies for mitigation.

Issue 1: Observed weight loss or reduced feed/water intake in treated animals.

- Question: My mice are losing more than 10% of their body weight after starting treatment with **RMC-0331**. What should I do?
- Answer:
  - Dose Reduction: Significant weight loss is a common indicator of poor tolerability. Consider reducing the dose of **RMC-0331**. If you started at the higher end of the reported range (250 mg/kg), a dose de-escalation to 150-200 mg/kg or lower may be warranted.
  - Vehicle and Formulation Assessment: The vehicle used for oral gavage can contribute to gastrointestinal distress. Ensure the formulation is appropriate and well-tolerated. If using

a suspension, ensure it is homogenous to prevent inconsistent dosing. For extended studies, some vehicles may be less suitable.

- Supportive Care: Provide supportive care to affected animals, such as supplemental hydration (e.g., hydrogel packs) and easily accessible, palatable food.
- Frequency of Dosing: If once-daily dosing is not well-tolerated, and the pharmacokinetic profile allows, exploring a different dosing schedule (e.g., every other day) might be an option, though this may impact efficacy.

Issue 2: Animals appear lethargic, hunched, or show other signs of distress.

- Question: Soon after dosing with **RMC-0331**, the animals become inactive and show signs of malaise. What could be the cause and how can I address it?
- Answer:
  - Acute Toxicity vs. Vehicle Effects: It is crucial to distinguish between toxicity from the compound and adverse reactions to the vehicle or the gavage procedure itself. Include a vehicle-only control group that undergoes the same procedures.
  - Pharmacokinetic/Pharmacodynamic (PK/PD) Analysis: The timing of the adverse signs relative to dosing can provide clues. If the effects are acute and transient, they may correlate with the peak plasma concentration ( $C_{max}$ ) of the drug.
  - Dose Titration: A careful dose-finding study is recommended to establish the maximum tolerated dose (MTD) in your specific animal model and strain. Start with a lower dose and gradually escalate while closely monitoring for any signs of toxicity.

Issue 3: How can I proactively monitor for potential toxicity?

- Question: What parameters should I be monitoring to detect early signs of **RMC-0331** toxicity?
- Answer: A comprehensive monitoring plan is essential for any in vivo study with a novel compound. Key parameters include:
  - Daily Monitoring:

- Body weight
- Food and water consumption
- Clinical signs (e.g., changes in posture, activity level, grooming, fur texture)
- Fecal consistency
- Weekly or Bi-weekly Monitoring:
  - Complete Blood Count (CBC) to check for hematological abnormalities.
  - Serum chemistry panel to assess liver and kidney function (e.g., ALT, AST, BUN, creatinine).
- End-of-Study Analysis:
  - Gross necropsy to identify any organ abnormalities.
  - Histopathological analysis of major organs (e.g., liver, kidneys, spleen, gastrointestinal tract) to detect microscopic changes.

## Quantitative Data Summary

Due to the limited publicly available toxicity data for **RMC-0331**, this table focuses on the reported efficacious dosing range. Researchers should establish a tolerable dose within this range for their specific model.

Compound	Animal Model	Dosing Route	Dosing Regimen	Reported Efficacious Dose Range	Reference
RMC-0331	Immunocompetent Mice	Oral (p.o.)	Once Daily (qd)	100 - 250 mg/kg	[2]

## Experimental Protocols

Protocol: In Vivo Tolerability and Efficacy Study of **RMC-0331**

- **Animal Model:** Select the appropriate tumor-bearing mouse model (e.g., xenograft, patient-derived xenograft (PDX), or genetically engineered mouse model).
- **Housing and Acclimatization:** House animals in a controlled environment and allow for an acclimatization period of at least one week before the start of the experiment.
- **Group Allocation:** Randomly assign animals to treatment groups (e.g., Vehicle control, **RMC-0331** low dose, **RMC-0331** high dose). A typical group size is 8-10 animals to ensure statistical power.
- **RMC-0331 Formulation:**
  - Prepare a stock solution of **RMC-0331** in a suitable solvent like DMSO.
  - For oral administration, the stock solution can be further diluted in a vehicle such as corn oil or a solution of PEG300, Tween-80, and saline.
  - Note: The choice of vehicle should be based on solubility and tolerability. Always test the vehicle alone in a control group.
- **Dose Administration:**
  - Administer **RMC-0331** or vehicle via oral gavage at the predetermined dose and schedule (e.g., once daily).
  - Ensure the volume administered is appropriate for the animal's weight (typically 5-10 mL/kg).
- **Monitoring:**
  - Measure tumor volume using calipers 2-3 times per week.
  - Record body weights daily for the first week and 3 times per week thereafter.
  - Perform daily clinical observations as detailed in the "Troubleshooting Guide."
- **Endpoint Criteria:** Define humane endpoints for the study, such as tumor volume exceeding a certain limit, body weight loss greater than 20%, or severe clinical signs of distress.

- Data Analysis: Analyze differences in tumor growth and body weight between groups using appropriate statistical methods.

## Visualizations

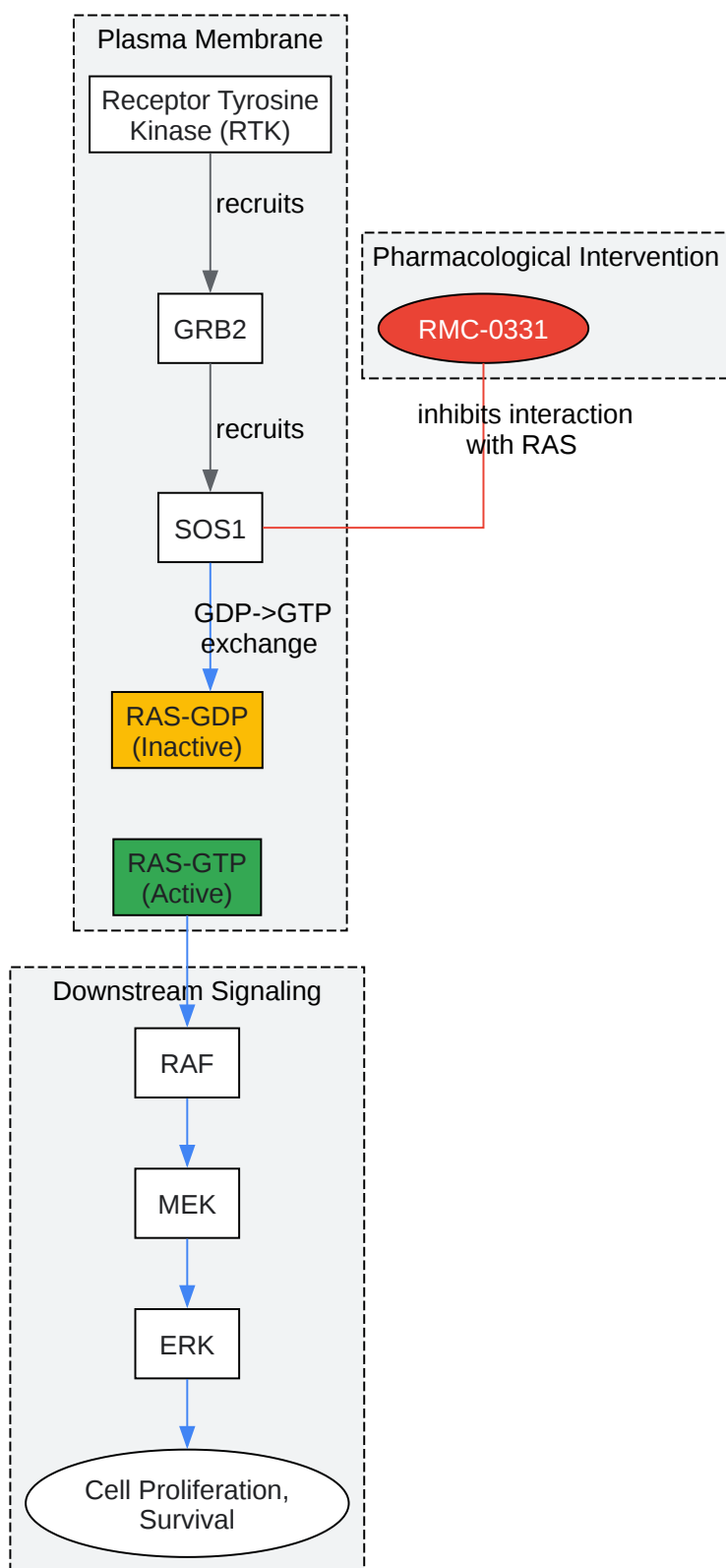

[Click to download full resolution via product page](#)

Caption: SOS1-RAS signaling pathway and the inhibitory action of **RMC-0331**.

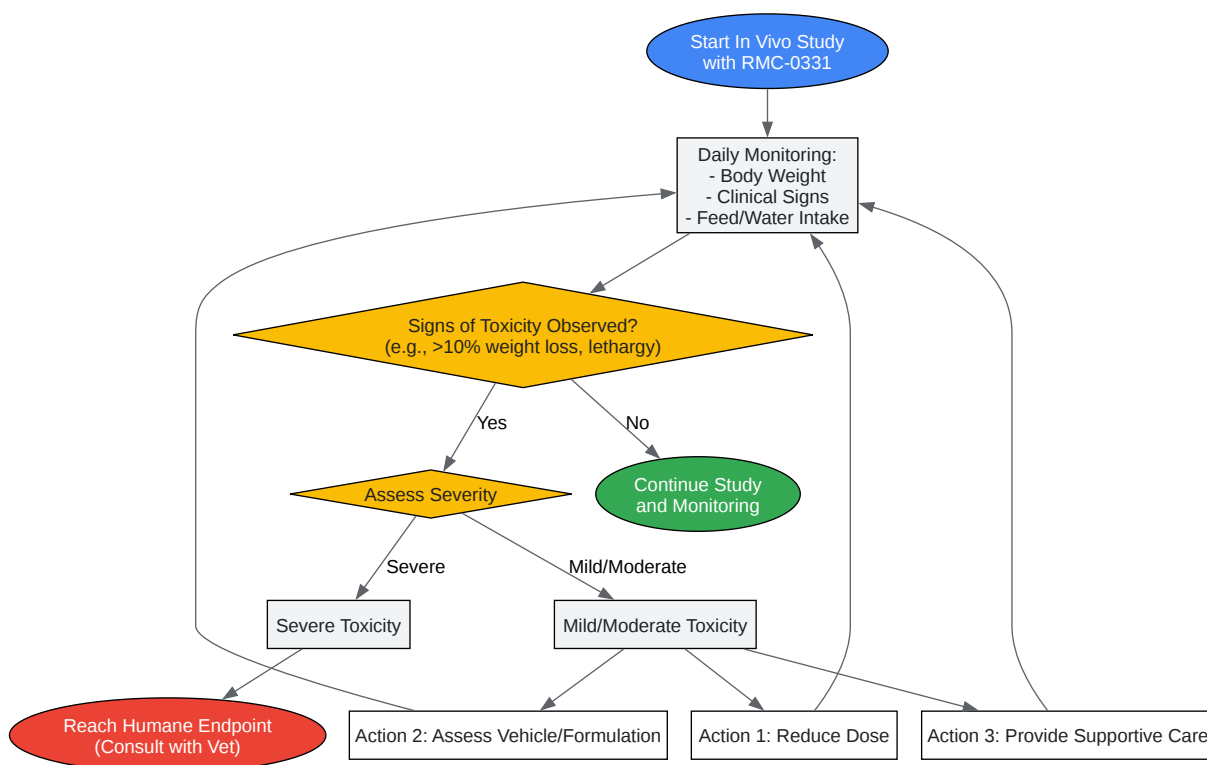

[Click to download full resolution via product page](#)

Caption: Logical workflow for troubleshooting in vivo toxicity with **RMC-0331**.

### Need Custom Synthesis?

BenchChem offers custom synthesis for rare earth carbides and specific isotopic labeling.

Email: [info@benchchem.com](mailto:info@benchchem.com) or [Request Quote Online](#).

## References

- 1. Discovery of a potent, selective, and orally bioavailable SOS1 inhibitor, RMC-0331, an in vivo tool compound that blocks RAS activation via disruption of the RAS-SOS1 interaction - American Chemical Society [[acs.digitellinc.com](https://acs.digitellinc.com)]
- 2. [medchemexpress.com](https://www.medchemexpress.com) [[medchemexpress.com](https://www.medchemexpress.com)]
- To cite this document: BenchChem. [Technical Support Center: RMC-0331 In Vivo Studies]. BenchChem, [2026]. [Online PDF]. Available at: [<https://www.benchchem.com/product/b8192633/docs#technical-support-center-rmc-0331-in-vivo-studies>]

---

### Disclaimer & Data Validity:

The information provided in this document is for Research Use Only (RUO) and is strictly not intended for diagnostic or therapeutic procedures. While BenchChem strives to provide accurate protocols, we make no warranties, express or implied, regarding the fitness of this product for every specific experimental setup.

**Technical Support:** The protocols provided are for reference purposes. Unsure if this reagent suits your experiment?

**Need Industrial/Bulk Grade?** [Request Custom Synthesis Quote](#)

# BenchChem

Our mission is to be the trusted global source of essential and advanced chemicals, empowering scientists and researchers to drive progress in science and industry.

## Contact

Address: 3281 E Guasti Rd

Ontario, CA 91761, United States

Phone: (601) 213-4426

Email: [info@benchchem.com](mailto:info@benchchem.com)

[Contact our Ph.D. Support Team for a compatibility check](#)