

Cyclopropylamine Building Blocks: A Medicinal Chemist's Technical Guide

Author: BenchChem Technical Support Team. **Date:** April 2026

Compound of Interest

Compound Name: *trans-C-(2-Methyl-cyclopropyl)-methylamine*

Cat. No.: B8187257

[Get Quote](#)

Executive Summary

Cyclopropylamines (CPAs) represent a "privileged scaffold" in modern medicinal chemistry, occupying a unique chemical space between aliphatic chains and aromatic rings.^{[1][2][3]} They are not merely structural spacers but active functional elements that modulate pKa, conformational entropy, and metabolic stability.^{[1][4][5][6]}

For the drug developer, the cyclopropylamine moiety offers a strategic tool to:

- **Lower Basicity:** Reduce pKa by ~1.5 units compared to isopropylamine, improving membrane permeability and reducing hERG liability.^{[1][4][5][6]}
- **Restrict Conformation:** Lock pharmacophores into bioactive conformations without the aromaticity penalty (solubility/toxicity).^{[1][4]}
- **Modulate Metabolism:** Block metabolic soft spots (e.g., dealkylation) or, conversely, act as mechanism-based inhibitors (suicide substrates) for specific enzymes.^{[1][3][5][6]}

This guide provides an in-depth technical analysis of CPA building blocks, from their physicochemical underpinnings to scalable synthesis and toxicology mitigation.^{[1][2][3][6]}

Physicochemical & Structural Profile^{[1][2][3][6][7][8]} ^[9]

The "s-Character" Effect on Basicity

The most critical property of cyclopropylamine is its reduced basicity compared to acyclic bioisosteres.^{[1][2][3]}

- Hybridization: The carbon atoms in a cyclopropane ring possess significant s-character in the C-H bonds and high s-character in the C-C bonds (Walsh orbitals).^[1]
- Electronic Consequence: The exocyclic C-N bond has increased s-character (), making the ring carbon more electronegative than a standard alkyl carbon.^{[1][3]} This pulls electron density away from the nitrogen lone pair, lowering its basicity.^{[1][4][5][6]}

Amine Type	Structure	pKa (Conjugate Acid)	Medicinal Chem Implication
Isopropylamine	<code>ngcontent-ng-c2699131324="" _nghost-ng-c2339441298="" class="inline ng-star-inserted"></code>	10.63	Highly basic; likely protonated at pH 7.4; potential for cation-trapping. [1] [3]
Cyclopropylamine	<code>ngcontent-ng-c2699131324="" _nghost-ng-c2339441298="" class="inline ng-star-inserted"></code>	9.10	Moderately basic; increased neutral fraction at physiological pH; improved permeability. [1] [3] [4]
Aniline	<code>ngcontent-ng-c2699131324="" _nghost-ng-c2339441298="" class="inline ng-star-inserted"></code>	4.6	Weakly basic; often poor solubility; potential toxicity issues. [1] [4]

Conformational Restriction

The cyclopropyl group acts as a rigid anchor.[\[1\]](#)[\[2\]](#)[\[4\]](#) Unlike an isopropyl group, which rotates freely, the cyclopropyl ring locks the vectors of the substituents.[\[1\]](#)[\[5\]](#)[\[6\]](#)

- Bioactive Conformation: In Ticagrelor (P2Y12 antagonist), the cyclopropylamine moiety fixes the orientation of the difluorophenyl group, optimizing -stacking interactions within the receptor pocket.[\[1\]](#)[\[6\]](#)

Synthetic Methodologies

Selecting the correct synthetic route is dictated by the substitution pattern and scale.[\[1\]](#)[\[2\]](#)[\[4\]](#)

Synthesis Decision Tree

The following logic flow guides the selection of the optimal synthetic method.

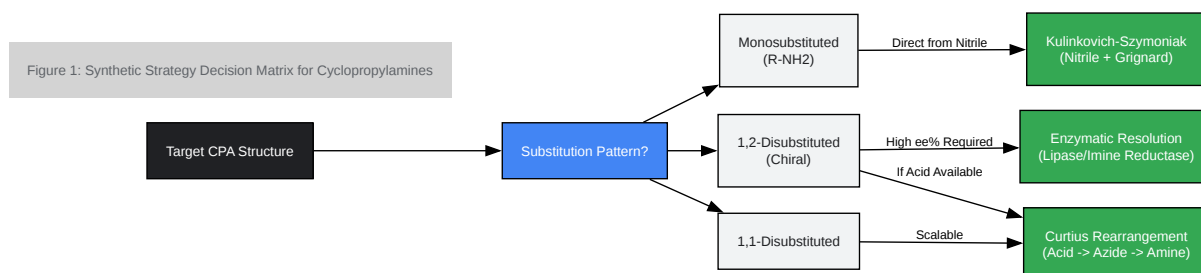

[Click to download full resolution via product page](#)

Protocol: Scalable Curtius Rearrangement

Target: *tert*-Butyl (1-cyclopropyl)cyclopropylcarbamate.[1][2][3] Rationale: The Kulinkovich reaction can be difficult to scale due to titanium waste and exotherms.[1][4] The Curtius rearrangement offers a robust, self-validating sequence for multi-gram synthesis.[1][2][3][6]

Reagents:

- 1-Cyclopropylcyclopropanecarboxylic acid (1.0 eq)[1][2][3]
- Ethyl chloroformate (1.7 eq)[1][2][3]
- Triethylamine (ngcontent-ng-c2699131324="" _nghost-ng-c2339441298="" class="inline ng-star-inserted">
) (1.3 eq)[1][3]
- Sodium azide (ngcontent-ng-c2699131324="" _nghost-ng-c2339441298="" class="inline ng-star-inserted">

) (1.8 eq)[1][3]

- tert-Butanol (ngcontent-ng-c2699131324="" _nghost-ng-c2339441298="" class="inline ng-star-inserted">

-BuOH) (Solvent/Reagent)[1][3]

Step-by-Step Methodology:

- Mixed Anhydride Formation:

- Dissolve carboxylic acid in anhydrous acetone at -5°C.
- Add ngcontent-ng-c2699131324="" _nghost-ng-c2339441298="" class="inline ng-star-inserted">

dropwise (maintain T < 0°C).[1][3][4]

- Add ethyl chloroformate slowly.[1][2][4] Checkpoint: Evolution of ngcontent-ng-c2699131324="" _nghost-ng-c2339441298="" class="inline ng-star-inserted"> gas ceases.[1][4] Stir for 2 hours at -5°C.
- Mechanistic Note: Low temperature prevents decomposition of the mixed anhydride.[4]

- Acyl Azide Formation:

- Add aqueous solution of dropwise at -5°C.
- Stir for 1.5 hours.
- Critical Safety Step: Do not isolate the acyl azide in dry form (explosion hazard).[1][4] Extract with toluene and keep in solution.[1][2][4]

- Curtius Rearrangement & Trapping:

- Dry the toluene layer (anhydrous ngcontent-ng-c2699131324="" _nghost-ng-c2339441298="" class="inline ng-star-inserted">

).[1][3][4]

- Heat the toluene solution to 90°C. Observation: Vigorous evolution indicates isocyanate formation.

).[1][4]

- Once gas evolution stops, add excess tert-butanol and reflux for 12 hours.
- Validation: IR spectroscopy will show disappearance of the azide peak (~2130 cm⁻¹) and appearance of the urethane carbonyl.

).[1][3]

- Purification:

- Concentrate in vacuo.
- Purify via silica gel chromatography (Hexane/EtOAc).

Medicinal Chemistry Applications

FDA-Approved Drugs Containing Cyclopropylamines

The prevalence of this moiety in approved drugs highlights its versatility.

Drug Name	Indication	CPA Role	Mechanism
Ticagrelor	Antiplatelet (ACS)	Potency/Binding	(1R,2S)-2-(3,4-difluorophenyl)cyclopropylamine fits a hydrophobic pocket; H-bonds via amine.[1][2][3][6]
Tranylcypromine	Antidepressant (MAOI)	Covalent Inhibition	Mechanism-based inactivator of MAO-A/B via ring opening.[1][2][3]
Ciprofloxacin	Antibiotic	Potency/Pk	N-cyclopropyl group improves potency against Gram-negative bacteria and cell penetration.[1][2][3]
Olaparib	PARP Inhibitor	Linker/Rigidity	Cyclopropanecarbonyl piperazine (amide) restricts conformation for PARP binding.[1][2][3][4]
Abacavir	Antiviral (HIV)	Lipophilicity	Cyclopropylamine increases lipophilicity compared to amino group, aiding CNS penetration.[1][2][3][4][6]

Case Study: LSD1 Inhibitors

Lysine-specific demethylase 1 (LSD1) is a target for AML and small cell lung cancer.[1][2][3]

- Challenge: Develop a potent inhibitor based on the tranylcypromine scaffold.

- Solution: Derivatives of trans-2-phenylcyclopropylamine (2-PCPA) were synthesized.^{[1][2][3]} The cyclopropyl ring positions the phenyl ring to interact with the FAD cofactor.^[4]
- Mechanism: The amine is oxidized by FAD to an imine, which then undergoes ring opening to form a covalent adduct with FAD, permanently disabling the enzyme.^{[1][5][6]}

Metabolic & Toxicology Considerations

The "Double-Edged Sword" of CYP Inhibition

While cyclopropylamines stabilize drugs against dealkylation, they are also notorious Mechanism-Based Inactivators (MBIs) of Cytochrome P450 enzymes (specifically CYP2D6 and CYP3A4).^{[1][2][3]}

Mechanism:

- SET Oxidation: CYP450 extracts a single electron (SET) from the nitrogen lone pair.^{[1][2][4]}
- Radical Formation: The resulting aminium radical cation is unstable.^{[1][2][4]}
- Ring Opening: The cyclopropyl ring opens to relieve strain, forming a reactive carbon-centered radical.^{[1][2][4]}
- Covalent Binding: This radical attacks the heme porphyrin of the CYP enzyme, leading to irreversible inactivation.^{[1][4]}

Visualization of CYP Inactivation Mechanism

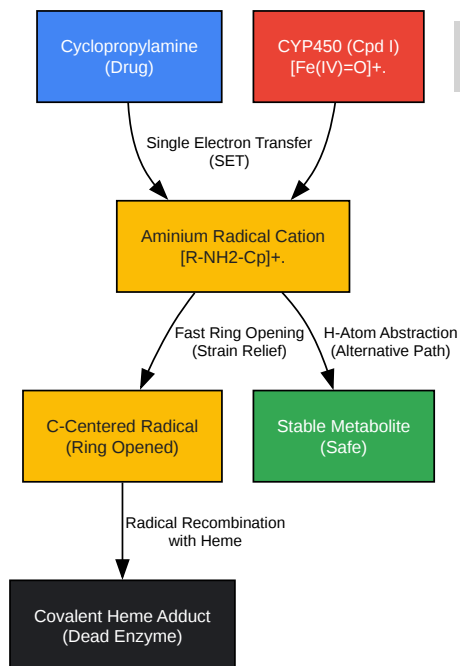

Figure 2: Mechanism-Based Inactivation (Suicide Inhibition) of CYP450 by Cyclopropylamines

[Click to download full resolution via product page](#)

[1][2][3][6]

Mitigation Strategies

To utilize the benefits of CPA without the toxicity:

- Steric Blocking: Substitution at the cyclopropyl carbons (e.g., gem-dimethyl) can slow down the ring-opening kinetics or sterically hinder the approach to the heme iron.[1][2][3]
- Electronic Modulation: Adding electron-withdrawing groups (fluorine) to the ring or adjacent amine reduces the propensity for the initial SET oxidation step.[1][2][4]

- Scaffold Hopping: Replacing the cyclopropylamine with a bicyclo[1.1.1]pentane amine (an emerging bioisostere) which maintains geometry but lacks the ring-opening instability.[\[1\]\[2\]\[3\]](#)

References

- Mechanism of CYP Inactivation: Hanzlik, R. P., & Tullman, R. H. (1982).[\[1\]\[4\]\[5\]\[6\]](#) Suicidal inactivation of cytochrome P-450 by cyclopropylamines.[\[1\]\[2\]\[3\]\[4\]\[7\]](#) Evidence for cation-radical intermediates.[\[1\]\[2\]\[3\]\[4\]](#) Journal of the American Chemical Society.[\[1\]\[4\]\[7\]](#) [Link\[1\]\[2\]\[3\]](#)
- Kulinkovich Reaction Review: Kulinkovich, O. G., & de Meijere, A. (2000).[\[1\]\[2\]\[4\]\[5\]\[6\]](#) 1,n-Dicarbonyl Titanium Intermediates from Monocarbonyl Organometallics and Their Application in Organic Synthesis. Chemical Reviews.[\[1\]\[2\]\[4\]](#) [Link\[1\]\[2\]\[3\]](#)
- Scalable Curtius Protocol: Wilsily, A., et al. (2012).[\[1\]\[2\]\[4\]\[5\]\[6\]](#) Scalable synthesis of (1-cyclopropyl)cyclopropylamine hydrochloride.[\[1\]\[2\]\[3\]\[8\]](#) Beilstein Journal of Organic Chemistry.[\[2\]\[4\]](#) [Link](#)
- pKa and Properties: Wiberg, K. B., et al. (1987).[\[1\]\[4\]\[5\]\[6\]](#) Substituent effects on the acidity of weak acids.[\[1\]\[4\]](#) 1. Bicyclo[1.1.1]pentane-1-carboxylic acid and bicyclo[2.2.2]octane-1-carboxylic acid.[\[1\]\[2\]\[3\]](#) Journal of the American Chemical Society.[\[1\]\[4\]\[7\]](#) (Contextual pKa data). [Link\[1\]\[2\]\[3\]](#)
- Ticagrelor Discovery: Springthorpe, B., et al. (2007).[\[1\]\[2\]\[4\]\[5\]\[6\]](#) From ATP to AZD6140: The discovery of an orally active reversible P2Y12 receptor antagonist for the prevention of thrombosis.[\[4\]](#) Bioorganic & Medicinal Chemistry Letters.[\[1\]\[2\]\[4\]](#) [Link](#)
- LSD1 Inhibitors: Zheng, Y. C., et al. (2016).[\[1\]\[2\]\[4\]\[5\]\[6\]](#) Triazole-dithiocarbamate based selective lysine specific demethylase 1 (LSD1) inactivators inhibit gastric cancer cell growth, invasion, and migration.[\[1\]\[2\]\[3\]\[6\]](#) Journal of Medicinal Chemistry.[\[4\]](#) [Link\[1\]\[2\]\[3\]](#)

Need Custom Synthesis?

BenchChem offers custom synthesis for rare earth carbides and specific isotopic labeling.

Email: info@benchchem.com or [Request Quote Online](#).

Sources

- [1. Ticagrelor | C23H28F2N6O4S | CID 9871419 - PubChem \[pubchem.ncbi.nlm.nih.gov\]](#)
- [2. Prasugrel - Wikipedia \[en.wikipedia.org\]](#)
- [3. Olaparib - Wikipedia \[en.wikipedia.org\]](#)
- [4. Cyclopropylamine | C3H7N | CID 69828 - PubChem \[pubchem.ncbi.nlm.nih.gov\]](#)
- [5. alfa-chemistry.com \[alfa-chemistry.com\]](#)
- [6. Cyclopropylamine | 765-30-0 \[chemicalbook.com\]](#)
- [7. Page loading... \[wap.guidechem.com\]](#)
- [8. Scalable synthesis of \(1-cyclopropyl\)cyclopropylamine hydrochloride - PMC \[pmc.ncbi.nlm.nih.gov\]](#)
- To cite this document: BenchChem. [Cyclopropylamine Building Blocks: A Medicinal Chemist's Technical Guide]. BenchChem, [2026]. [Online PDF]. Available at: [\[https://www.benchchem.com/product/b8187257/docs#cyclopropylamine-building-blocks-a-medicinal-chemist-s-technical-guide\]](https://www.benchchem.com/product/b8187257/docs#cyclopropylamine-building-blocks-a-medicinal-chemist-s-technical-guide)

Disclaimer & Data Validity:

The information provided in this document is for Research Use Only (RUO) and is strictly not intended for diagnostic or therapeutic procedures. While BenchChem strives to provide accurate protocols, we make no warranties, express or implied, regarding the fitness of this product for every specific experimental setup.

Technical Support: The protocols provided are for reference purposes. Unsure if this reagent suits your experiment?

Need Industrial/Bulk Grade? [Request Custom Synthesis Quote](#)

BenchChem

Our mission is to be the trusted global source of essential and advanced chemicals, empowering scientists and researchers to drive progress in science and industry.

Contact

Address: 3281 E Guasti Rd

Ontario, CA 91761, United States

Phone: (601) 213-4426

Email: info@benchchem.com

[Contact our Ph.D. Support Team for a compatibility check](#)