

The Role of BTTP in Bioconjugation: A Technical Guide

Author: BenchChem Technical Support Team. **Date:** April 2026

Compound of Interest

Compound Name: *BTTP*
Cat. No.: *B8181062*

[Get Quote](#)

For Researchers, Scientists, and Drug Development Professionals

Introduction

In the landscape of bioconjugation, the precise and efficient covalent linking of molecules to biomolecules is paramount for advancing therapeutic and diagnostic applications. Among the most powerful tools in this field is the Copper(I)-catalyzed Azide-Alkyne Cycloaddition (CuAAC), a cornerstone of "click chemistry." The efficacy and biocompatibility of this reaction are significantly influenced by the choice of the copper(I)-chelating ligand. This technical guide provides an in-depth exploration of **BTTP** (2-[4-[[bis[(1-tert-butyltriazol-4-yl)methyl]amino]methyl]triazol-1-yl]acetic acid), a third-generation ligand designed to accelerate the CuAAC reaction, enabling robust bioconjugation with enhanced performance and reduced cellular toxicity.

Core Concepts: BTTP and the CuAAC Reaction

Bioconjugation is the chemical strategy of forming a stable covalent bond between two molecules, where at least one is a biomolecule.^[1] This technique is fundamental in creating advanced therapeutics like antibody-drug conjugates (ADCs), developing diagnostic probes, and understanding complex biological processes.^{[1][2]}

The CuAAC reaction is a highly efficient and specific method for covalently linking a molecule containing an azide functional group with a molecule containing a terminal alkyne. This reaction is "bioorthogonal," meaning it proceeds with high efficiency under physiological conditions without interfering with native biological processes.[3] The role of the copper(I) catalyst is to activate the alkyne for a rapid and regioselective reaction with the azide, forming a stable triazole linkage.

BTTP is a tris(triazolylmethyl)amine-based ligand that plays a crucial role in optimizing the CuAAC reaction for bioconjugation.[3][4] Its primary functions are:

- **Reaction Acceleration:** **BTTP** significantly enhances the rate of the CuAAC reaction, allowing for efficient conjugation at low reactant concentrations.[1][5][6]
- **Stabilization of Copper(I):** The ligand protects the catalytically active Cu(I) oxidation state from oxidation and disproportionation in aqueous environments.[2][7]
- **Reduced Cytotoxicity:** By effectively chelating the copper ions, **BTTP** minimizes their inherent cytotoxicity, making it suitable for applications in living systems.[1][5][6]

Quantitative Data Presentation

The performance of **BTTP** is best understood in comparison to other commonly used CuAAC ligands. The following table summarizes kinetic data from a fluorogenic assay comparing the rate of cycloaddition product formation over time for different ligands.

Ligand	Time (minutes)	Cycloaddition Product (%)
BTTPS	10	~35
20	~50	
30	>50	
BTTP	10	~25
20	~40	
30	~45	
BTES	10	~25
20	~40	
30	~45	
TBTA	10	<20
20	<20	
30	<20	

Data is estimated from the graphical representation in "Sulfated Ligands for the Copper(I)-catalyzed Azide-Alkyne Cycloaddition".^[3] **BTTPS**, a sulfated derivative of **BTTP**, shows the highest reaction rate. **BTTP** and **BTES** exhibit comparable and significantly higher rate acceleration compared to the first-generation ligand, **TBTA**.

Experimental Protocols

The following are detailed methodologies for key experiments involving **BTTP**-mediated bioconjugation.

Protocol 1: General In Vitro Bioconjugation using **BTTP**-mediated CuAAC

This protocol describes a general procedure for conjugating an alkyne-containing biomolecule to an azide-containing molecule (e.g., a fluorescent dye or biotin).

Materials:

- Alkyne-modified biomolecule (e.g., protein, peptide)
- Azide-containing molecule (e.g., fluorescent probe, biotin-azide)
- **BTTP** ligand
- Copper(II) sulfate (CuSO_4)
- Sodium Ascorbate
- Reaction Buffer (e.g., phosphate-buffered saline (PBS), pH 7.4)
- Purification system (e.g., size-exclusion chromatography, dialysis)

Procedure:

- Reagent Preparation:
 - Prepare a stock solution of the alkyne-modified biomolecule in the reaction buffer.
 - Prepare a stock solution of the azide-containing molecule in a compatible solvent (e.g., DMSO).
 - Prepare a stock solution of **BTTP** in a suitable solvent (e.g., DMSO, DMF, or MeOH).[1]
 - Prepare a stock solution of CuSO_4 in water.
 - Freshly prepare a stock solution of sodium ascorbate in water.
- Reaction Setup:
 - In a reaction vessel, combine the alkyne-modified biomolecule and the azide-containing molecule in the reaction buffer.
 - In a separate tube, prepare a premix of the **BTTP** ligand and CuSO_4 . A typical ligand-to-copper ratio is 5:1 to 6:1.[3]

- Add the **BTTP**/CuSO₄ premix to the reaction mixture.
- Initiation and Incubation:
 - Initiate the reaction by adding the freshly prepared sodium ascorbate solution. A typical final concentration is 2.5 mM.[3]
 - Incubate the reaction at room temperature for 1-4 hours. Reaction progress can be monitored by an appropriate analytical technique (e.g., HPLC, SDS-PAGE).
- Purification:
 - Upon completion, purify the bioconjugate from excess reagents and byproducts using a suitable method such as size-exclusion chromatography, dialysis, or affinity chromatography.

Protocol 2: Live Cell Surface Labeling using BTTP-mediated CuAAC

This protocol outlines the steps for labeling the surface of live cells that have been metabolically engineered to display azide or alkyne functionalities.

Materials:

- Live cells cultured with an azide or alkyne metabolic precursor (e.g., Ac₄ManNAz or Ac₄ManNAI)
- Fluorescently-labeled alkyne or azide probe
- **BTTP** ligand
- Copper(II) sulfate (CuSO₄)
- Sodium Ascorbate
- Cell culture medium
- Bovine Serum Albumin (BSA)

- Fluorescence microscope or flow cytometer

Procedure:

- Cell Preparation:
 - Culture cells in the presence of an appropriate metabolic precursor (e.g., 50 μM Ac₄ManNAz) for 2-3 days to introduce the desired functional group onto cell surface glycans.[3]
 - Harvest the cells and wash them with a serum-free medium containing 1% BSA.
- Labeling Reaction:
 - Resuspend the cells in a reaction buffer (e.g., serum-free medium).
 - Add the fluorescently labeled alkyne or azide probe to the cell suspension (e.g., 50 μM).[3]
 - Prepare a premix of **BTTP** and CuSO₄ in the reaction buffer at a 6:1 molar ratio.[3]
 - Add the **BTTP**/CuSO₄ premix to the cell suspension. A final CuSO₄ concentration of 50-75 μM is often used.[3]
 - Add sodium ascorbate to a final concentration of 2.5 mM to initiate the reaction.[3]
- Incubation and Washing:
 - Incubate the cells at room temperature for a short duration (e.g., 5-15 minutes).[3]
 - Quench the reaction by adding a chelating agent like BCS or EDTA, or by washing the cells.
 - Wash the cells multiple times with fresh medium to remove unreacted reagents.
- Analysis:
 - Analyze the labeled cells using fluorescence microscopy or flow cytometry.

Mandatory Visualizations

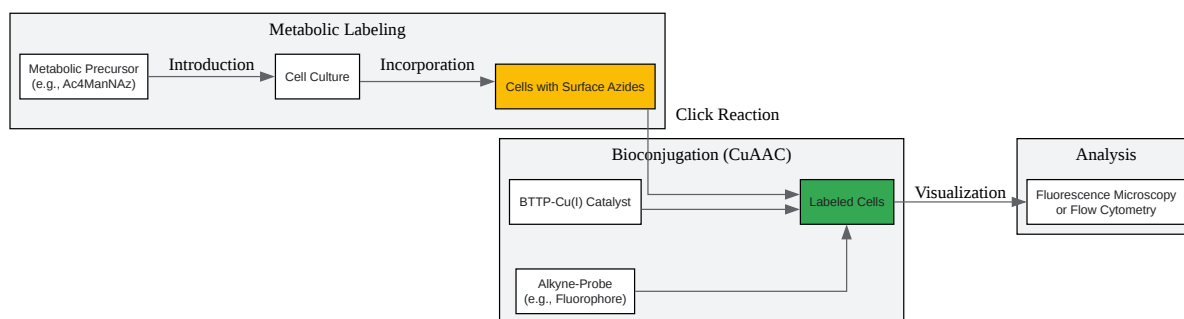

[Click to download full resolution via product page](#)

Caption: Workflow for live cell surface labeling using **BTTP**-mediated click chemistry.

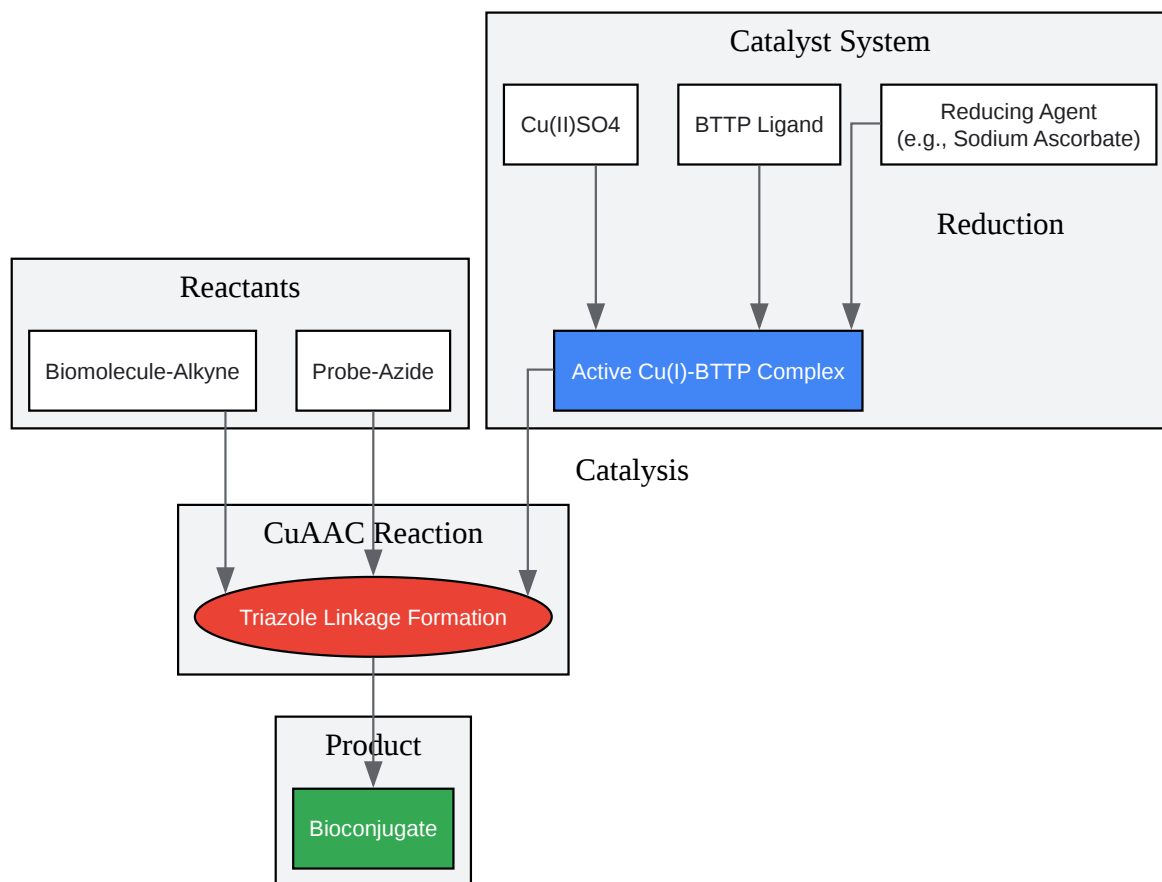

[Click to download full resolution via product page](#)

Caption: Mechanism of **BTTP** in accelerating the CuAAC bioconjugation reaction.

Need Custom Synthesis?

BenchChem offers custom synthesis for rare earth carbides and specific isotopic labeling.

Email: info@benchchem.com or [Request Quote Online](#).

References

- [1. prod-vector-labs-wordpress-media.s3.amazonaws.com:443 \[prod-vector-labs-wordpress-media.s3.amazonaws.com:443\]](#)
- [2. ijpsjournal.com \[ijpsjournal.com\]](#)
- [3. Sulfated Ligands for the Copper\(I\)-catalyzed Azide-Alkyne Cycloaddition - PMC \[pmc.ncbi.nlm.nih.gov\]](#)
- [4. medchemexpress.com \[medchemexpress.com\]](#)
- [5. vectorlabs.com \[vectorlabs.com\]](#)
- [6. BTTP, 1341215-17-5 | BroadPharm \[broadpharm.com\]](#)
- [7. vectorlabs.com \[vectorlabs.com\]](#)
- [To cite this document: BenchChem. \[The Role of BTTP in Bioconjugation: A Technical Guide\]. BenchChem, \[2026\]. \[Online PDF\]. Available at: \[https://www.benchchem.com/product/b8181062/docs#the-role-of-bttp-in-bioconjugation-a-technical-guide\]](#)

Disclaimer & Data Validity:

The information provided in this document is for Research Use Only (RUO) and is strictly not intended for diagnostic or therapeutic procedures. While BenchChem strives to provide accurate protocols, we make no warranties, express or implied, regarding the fitness of this product for every specific experimental setup.

Technical Support: The protocols provided are for reference purposes. Unsure if this reagent suits your experiment?

Need Industrial/Bulk Grade? [Request Custom Synthesis Quote](#)

BenchChem

Our mission is to be the trusted global source of essential and advanced chemicals, empowering scientists and researchers to drive progress in science and industry.

Contact

Address: 3281 E Guasti Rd
Ontario, CA 91761, United States
Phone: (601) 213-4426
Email: info@benchchem.com

Contact our Ph.D. Support Team for a compatibility check