

# Technical Guide: Stability & Storage of Long-Chain Alkyl Azide Linkers

**Author:** BenchChem Technical Support Team. **Date:** May 2026

## Compound of Interest

Compound Name: *N-Boc-9-azidononan-1-amine*

Cat. No.: *B8179079*

[Get Quote](#)

## Part 1: Executive Summary

Long-chain alkyl azide linkers are the backbone of modern bioconjugation, serving as critical components in Antibody-Drug Conjugates (ADCs), PROTACs, and surface immobilization technologies. While the azide moiety is kinetically stable under physiological conditions, it possesses high potential energy. In storage, this potential energy can manifest as decomposition or unwanted reactivity if not managed with precision.<sup>[1][2]</sup>

This guide moves beyond basic "store at -20°C" advice. It dissects the physicochemical drivers of azide instability—specifically thermal nitrene formation and photolytic rearrangement—and provides a self-validating protocol for assessing linker integrity.

## Part 2: The Chemical Physics of Azide Stability

To ensure stability, one must understand the failure modes. Alkyl azides ( ) are resonance-stabilized but thermodynamically unstable relative to molecular nitrogen ( ).

### The "Rule of Six" and Safety

Safety is the precursor to stability. A fundamental heuristic in high-energy materials science is the Rule of Six, which states that organic azides are generally safe to handle and store if the ratio of carbon (plus other non-nitrogen atoms) to energetic nitrogen atoms is at least 6:1.[3]

(Note: Some literature simplifies this to

).[2]

Long-chain alkyl linkers (e.g.,

to

chains or PEGylated variants) typically satisfy this rule easily, rendering them non-explosive under standard storage. However, "safe from explosion" does not mean "chemically inert."

## Degradation Mechanisms

The primary degradation pathways for alkyl azides in storage are Nitrene Formation (thermal/photochemical) and Staudinger-type Reduction (chemical).

- Thermal Decomposition: At elevated temperatures (typically  $100^{\circ}\text{C}$ , but slow rates occur lower), the azide expels nitrogen to form a singlet nitrene. This highly reactive intermediate immediately rearranges, often via a 1,2-hydride shift, to form an imine, which hydrolyzes to an aldehyde and amine.
- Photolysis: Exposure to UV (and even ambient fluorescent light) promotes the azide to an excited singlet state, leading to nitrogen extrusion and nitrene formation. This is the most common cause of shelf-life failure in clear glass vials.

## Visualizing the Failure Pathways

The following diagram maps the degradation logic. Use this to troubleshoot unexpected impurities.

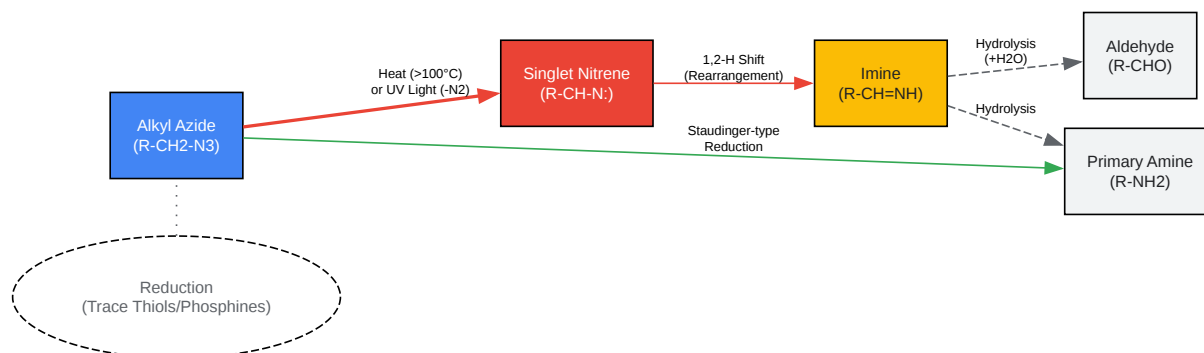

[Click to download full resolution via product page](#)

Figure 1: Mechanistic pathways of alkyl azide degradation. The red path indicates the primary storage risk (Nitrene formation via light/heat).

## Part 3: Critical Storage Parameters

Based on the degradation mechanisms, the following storage ecosystem is required.

### Temperature: The Kinetic Trap

Store long-chain alkyl azides at -20°C.

- Why: While alkyl azides are stable at room temperature (C) for weeks, Arrhenius kinetics dictate that lowering the temperature to C effectively halts the slow thermal extrusion of nitrogen.
- Warning: Avoid repeated freeze-thaw cycles. For liquid linkers, this can induce micro-precipitation or aggregation. Aliquot reagents upon receipt.

### Light: The Silent Killer

Strict darkness is mandatory.

- Why: The

transition of the azide group absorbs in the UV region but tails into the visible spectrum. Ambient lab lighting (fluorescent tubes) can induce photolysis over months of storage.

- Protocol: Use amber glass vials wrapped in aluminum foil. Secondary containment in an opaque cardboard box is best practice.

## Chemical Environment[2][4][5][6][7][8][9][10]

- Solvents: Store as a neat oil/solid if possible. If solution storage is necessary, use non-nucleophilic, non-reducing solvents like anhydrous DMSO or DMF. Avoid halogenated solvents (DCM/Chloroform) for long-term storage as they can form explosive di-/tri-azidomethane species via radical exchange over very long periods (though rare for long chains, it is a known hazard).
- Incompatibilities: Isolate from phosphines (Triphenylphosphine), thiols (DTT, BME), and strong acids.

## Part 4: Analytical Quality Control (QC)

Trust but verify. A "stable" reagent is only as good as the data proving it.

Method	What it Detects	Acceptance Criteria
FT-IR	Azide functional group integrity	Strong, distinct peak at $\sim 2100$ $\text{cm}^{-1}$ (asymmetric stretch). Disappearance indicates decomposition.
$^1\text{H}$ NMR	Structural purity & rearrangement	-methylene protons adjacent to azide typically appear at $\sim 3.2$ – $3.4$ ppm. Shift to $\sim 2.7$ ppm suggests amine formation.
HPLC-UV/MS	Purity & specific impurities	Single peak $>95\%$ purity. Mass shift of $-28$ Da (loss of $\text{N}_2$ ) or $+2$ Da (reduction to amine) in MS.

## Part 5: Protocol – Accelerated Stability Testing

Do not rely on vendor claims alone. When qualifying a new linker for a critical clinical campaign, perform this Accelerated Stability Test (AST).

### Workflow Diagram

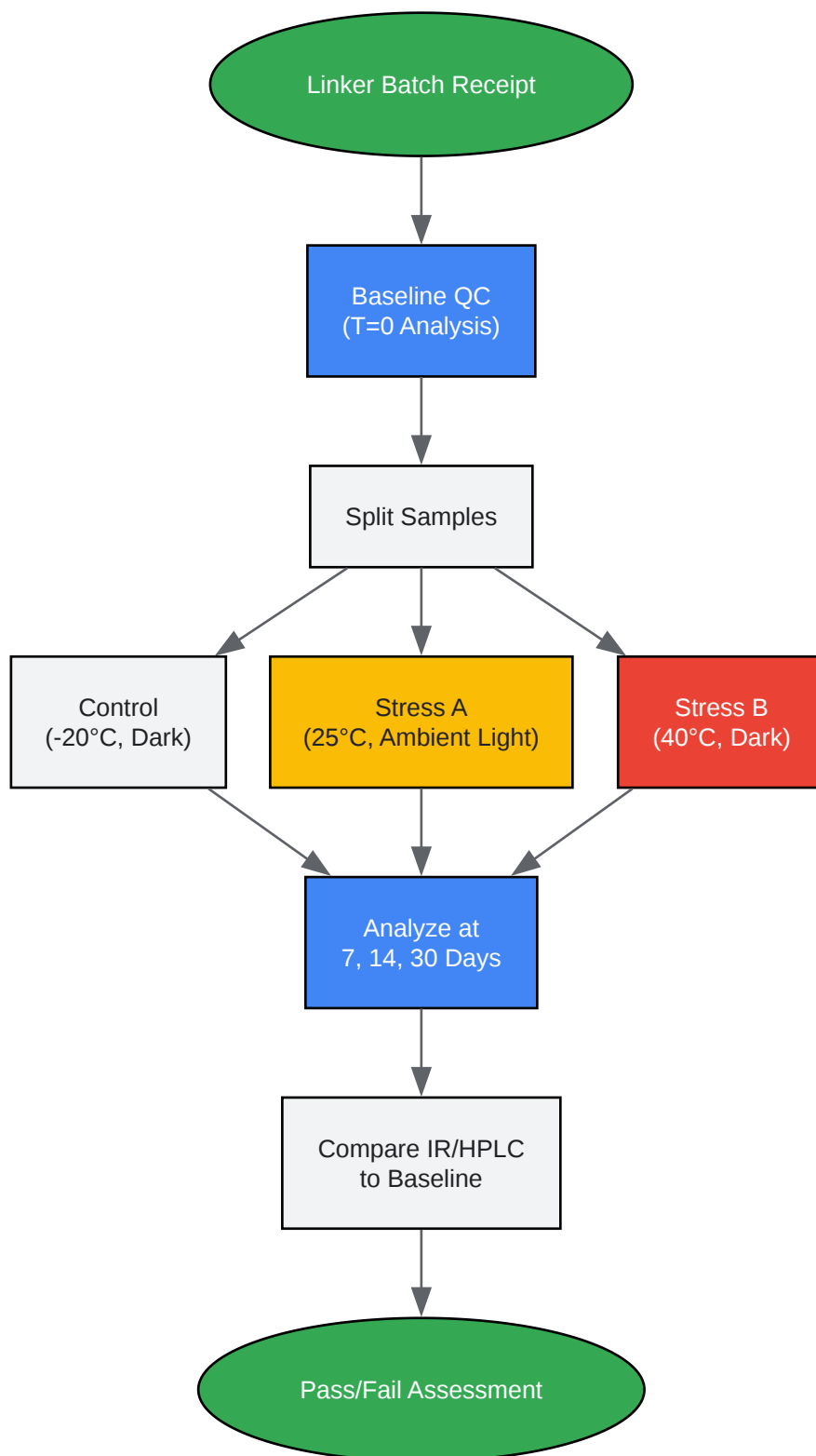

[Click to download full resolution via product page](#)

Figure 2: Accelerated Stability Testing (AST) workflow for validating linker integrity.

## Step-by-Step Methodology

- Baseline Analysis (T=0):
  - Dissolve ~5 mg of linker in  
  
or  
  
.
  - Acquire  $^1\text{H}$  NMR (64 scans) and FT-IR.
  - Record the integration of the  
  
-methylene protons (3.3 ppm) relative to the terminal methyl or PEG backbone.
- Sample Preparation:
  - Prepare 3 identical vials, each containing 10 mg of neat linker (or 100  $\mu\text{L}$  of 100 mM stock).
  - Vial A (Control): Wrap in foil, store at  $-20^\circ\text{C}$ .
  - Vial B (Photostress): Clear glass, store at benchtop ( $20\text{-}25^\circ\text{C}$ ) under fluorescent light.
  - Vial C (Thermal Stress): Wrap in foil, store at  $40^\circ\text{C}$  (heat block).
- Timepoints:
  - Evaluate at Day 7, Day 14, and Day 30.
- Readout & Analysis:
  - Visual Check: Look for yellowing (formation of azo/imine chromophores) or precipitation.
  - IR Check: A decrease in the ratio of the azide peak ( $2100\text{ cm}^{-1}$ ) to the C-H stretch ( $2900\text{ cm}^{-1}$ ) in Vial B/C compared to Vial A indicates degradation.
  - NMR Confirmation: If IR suggests degradation, run NMR. Look for new peaks at 9-10 ppm (aldehyde) or 2-3 ppm (amine).

- Pass Criteria:
  - Vial A must show < 2% degradation relative to T=0.
  - Vial B/C data informs handling constraints (e.g., "Stable for 24h at RT in light" vs "Protect from light immediately").

## Part 6: References

- Safe Handling of Azides. University of Pittsburgh, Department of Environmental Health and Safety. (2013).[2] Guidelines on the "Rule of Six" and storage parameters. [\[Link\]](#)
- Organic Azides: Syntheses and Applications. Bräse, S., et al. *Angewandte Chemie International Edition*, 44(33), 5188-5240. (2005).[4][5][6] Comprehensive review on azide stability and reactivity. [\[Link\]](#)
- Photolysis of Alkyl Azides. Kyba, E. P., & Abramovitch, R. A.[7] *Journal of the American Chemical Society*. [7] Mechanistic details on photochemical degradation. [\[Link\]](#)
- Bioconjugation via Azide-Alkyne Cycloaddition. National Institutes of Health (NIH) / PMC. Practical considerations for handling azide linkers in drug development. [\[Link\]](#)
- Storage and Handling of Organic Azides. University of California, Santa Barbara. Standard Operating Procedures for azide storage. [\[Link\]](#)

### Need Custom Synthesis?

BenchChem offers custom synthesis for rare earth carbides and specific isotopic labeling.

Email: [info@benchchem.com](mailto:info@benchchem.com) or [Request Quote Online](#).

## Sources

- 1. [Information on Azide Compounds – Stanford Environmental Health & Safety \[ehs.stanford.edu\]](#)
- 2. [safety.pitt.edu \[safety.pitt.edu\]](#)
- 3. [KIT - IOC - Bräse - Research - Research interests - Azide \[ioc.kit.edu\]](#)

- [4. uvic.ca](http://4. uvic.ca) [[uvic.ca](http://uvic.ca)]
- [5. researchgate.net](http://5. researchgate.net) [[researchgate.net](http://researchgate.net)]
- [6. researchgate.net](http://6. researchgate.net) [[researchgate.net](http://researchgate.net)]
- [7. pubs.acs.org](http://7. pubs.acs.org) [[pubs.acs.org](http://pubs.acs.org)]
- To cite this document: BenchChem. [Technical Guide: Stability & Storage of Long-Chain Alkyl Azide Linkers]. BenchChem, [2026]. [Online PDF]. Available at: [<https://www.benchchem.com/product/b8179079/docs#technical-guide-stability-storage-of-long-chain-alkyl-azide-linkers>]

---

### Disclaimer & Data Validity:

The information provided in this document is for Research Use Only (RUO) and is strictly not intended for diagnostic or therapeutic procedures. While BenchChem strives to provide accurate protocols, we make no warranties, express or implied, regarding the fitness of this product for every specific experimental setup.

**Technical Support:** The protocols provided are for reference purposes. Unsure if this reagent suits your experiment?

**Need Industrial/Bulk Grade?** [Request Custom Synthesis Quote](#)

## BenchChem

Our mission is to be the trusted global source of essential and advanced chemicals, empowering scientists and researchers to drive progress in science and industry.

### Contact

Address: 3281 E Guasti Rd  
Ontario, CA 91761, United States  
Phone: (601) 213-4426  
Email: [info@benchchem.com](mailto:info@benchchem.com)

[Contact our Ph.D. Support Team for a compatibility check](#)

