

Application Note: Engineering Pyrazole-4-Carbonitrile Fluorescent Probes for Microenvironment Sensing

Author: BenchChem Technical Support Team. **Date:** April 2026

Compound of Interest

Compound Name: 1-(4-Chlorobenzyl)-1H-pyrazole-4-carbonitrile

Cat. No.: B8158803

[Get Quote](#)

Executive Summary

The development of small-molecule fluorescent probes is a critical frontier in bioimaging, microenvironment sensing, and theranostic drug development. Among heterocyclic scaffolds, pyrazole-4-carbonitrile derivatives have emerged as highly versatile fluorophores[1]. By leveraging a highly tunable Donor- π -Acceptor (D- π -A) architecture, these molecules exhibit pronounced solvatochromism, high quantum yields, and extreme sensitivity to local polarity and hydrogen-bonding environments[1][2]. This application note details the structural rationale, green synthetic methodologies, and photophysical characterization protocols required to develop and validate pyrazole-4-carbonitrile probes for advanced analytical applications.

Structural Rationale & Photophysical Mechanisms

The photophysical brilliance of pyrazole-4-carbonitrile stems from its intrinsic push-pull electronic system[3]. The cyano (-CN) group at the 4-position of the pyrazole ring acts as a powerful electron acceptor, drastically lowering the Lowest Unoccupied Molecular Orbital (LUMO) energy[4]. When functionalized with electron-donating groups (e.g., arylamines or

substituted phenyl rings) at the 1-, 3-, or 5-positions, the molecule forms a highly conjugated D- π -A bridge[3][4].

Upon photoexcitation, electron density rapidly shifts from the donor moiety to the cyano acceptor, generating an Intramolecular Charge Transfer (ICT) state[1]. The stabilization of this ICT state is highly dependent on the surrounding microenvironment. In rigid or hydrophobic environments (such as the hydrophobic pockets of proteins or cyclodextrin nanocavities), non-radiative decay pathways are suppressed, leading to a significant enhancement in fluorescence lifetime and quantum yield[2].

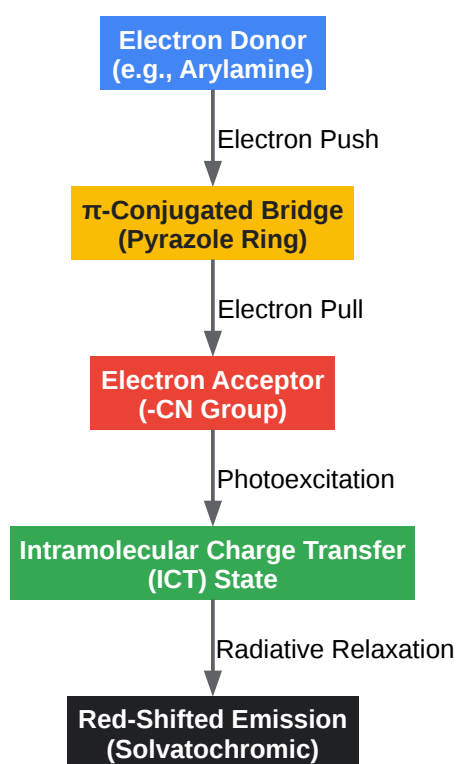

[Click to download full resolution via product page](#)

Logical flow of the Donor- π -Acceptor mechanism driving ICT in pyrazole-4-carbonitrile probes.

Synthetic Workflow: Multicomponent Assembly

Historically, synthesizing complex pyrazoles required multi-step pathways with low atom economy. Modern approaches utilize One-Pot Multicomponent Reactions (MCRs), which condense an aromatic aldehyde, malononitrile, and a hydrazine derivative in a single vessel[5][6].

The reaction proceeds via a sequential cascade:

- Knoevenagel Condensation: The aldehyde and malononitrile react to form an electrophilic alkene intermediate[7].
- Michael Addition & Cyclization: The hydrazine attacks the alkene, followed by intramolecular cyclization and dehydration to yield the fully conjugated pyrazole-4-carbonitrile[7][8].

Recent protocols employ green catalysts—such as Pd(II) thiazole complexes, orthophosphoric acid, or even simple NaCl in aqueous media—coupled with ultrasonic irradiation to drive yields up to 97% within minutes[5][7][8].

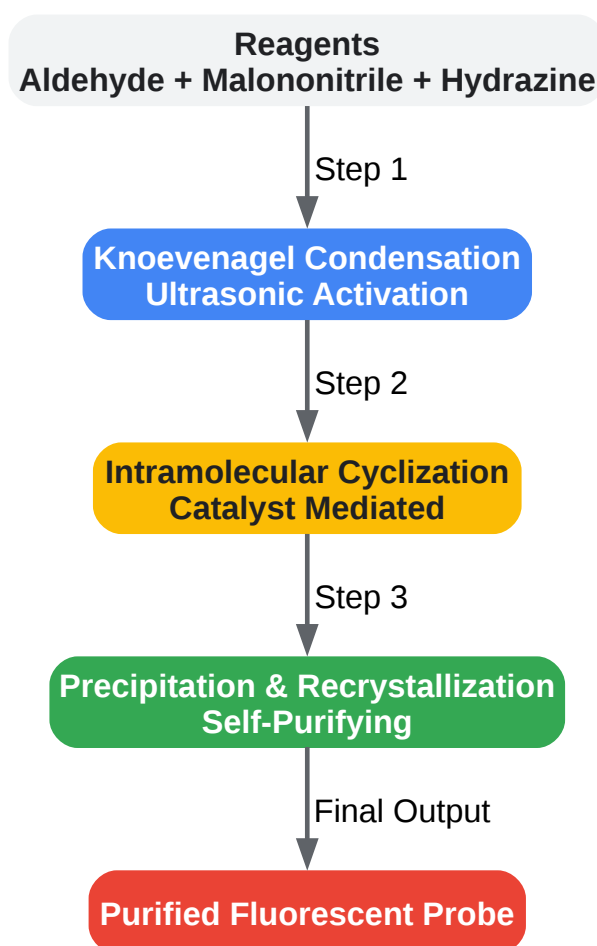

[Click to download full resolution via product page](#)

Step-by-step synthetic workflow for the multicomponent assembly of pyrazole-4-carbonitriles.

Protocol 1: One-Pot Ultrasonic Synthesis of Pyrazole-4-Carbonitrile Probes

Objective: Rapid, high-yield synthesis of a D- π -A pyrazole-4-carbonitrile fluorophore utilizing green chemistry principles[5][6].

Materials:

- Aromatic aldehyde (1.0 mmol)
- Malononitrile (1.0 mmol)
- Phenylhydrazine (1.0 mmol)
- Catalyst: Pd(II) thiazole complex (or 1 mol% H₃PO₄/ NaCl as alternatives)[5][7][8]
- Solvent: Ethanol/Water (1:1 v/v)

Step-by-Step Methodology:

- Reagent Solvation: In a 50 mL round-bottom flask, dissolve 1.0 mmol of the aromatic aldehyde and 1.0 mmol of malononitrile in 10 mL of the EtOH/ H₂O mixture.
 - Causality: The polar protic solvent mixture stabilizes the transition states of the Knoevenagel condensation while ensuring the final, highly conjugated hydrophobic product will precipitate out of solution, driving the equilibrium forward[7].
- Catalytic Activation: Add the selected catalyst to the mixture.
 - Causality: The Lewis acidic nature of the catalyst activates the carbonyl carbon of the aldehyde, drastically lowering the activation energy required for nucleophilic attack by malononitrile[6].
- Ultrasonic Irradiation (Phase 1): Subject the flask to ultrasonic irradiation (e.g., 40 kHz) at room temperature for 5–10 minutes.

- Causality: Sonication induces acoustic cavitation. The rapid formation and collapse of microbubbles generate localized hot spots that accelerate the condensation step, replacing hours of thermal refluxing[5].
- Cyclization (Phase 2): Add 1.0 mmol of phenylhydrazine dropwise to the reaction mass. Continue sonication for an additional 15–20 minutes.
- Isolation & Self-Validation:
 - Self-Validating Step: The reaction is deemed successful when a dense, colored solid precipitates directly from the reaction matrix[7]. This visual cue indicates that the Knoevenagel intermediate has successfully undergone cyclization and dehydration.
 - Monitor final completion via TLC (DCM:Methanol 9:1)[8]. Filter the precipitate and recrystallize from hot ethanol to yield the pure fluorophore.

Photophysical Characterization in Host-Guest Systems

To validate the microenvironment-sensing capabilities of the synthesized probe, host-guest encapsulation models are frequently employed. By titrating the probe with supramolecular hosts like β -cyclodextrin (β -CD), researchers can simulate how the probe behaves when entering hydrophobic biological pockets (e.g., cell membranes or protein binding sites)[1][2].

Table 1: Photophysical Properties of Pyrazole-4-Carbonitrile (PZ) in Host-Guest Environments

Microenvironment	Probe:Host Stoichiometry	Average Lifetime (τ , ns)	Anisotropy (r _{ss}) Trend	Environmental State
Water	Free Probe	1.70	Low	Highly polar, unshielded
0.4–3.8 mM β -CD	1:1 Complex	~2.10	Moderate	Partially shielded, restricted
>4.0 mM β -CD	1:2 Complex	~2.65	High	Hydrophobic, highly rigidified

Data synthesized from time-resolved fluorescence studies of pyrazoline-pyrazole-4-carbonitrile derivatives[1][2].

Protocol 2: Time-Resolved Fluorescence & Anisotropy Analysis

Objective: Determine the fluorescence lifetime and binding stoichiometry of the probe to validate its sensitivity to environmental rigidity and polarity[1][2].

Materials:

- Purified pyrazole-4-carbonitrile probe (e.g., PZ derivative)
- β -cyclodextrin (β -CD)
- Time-Correlated Single Photon Counting (TCSPC) spectrometer

Step-by-Step Methodology:

- Stock Preparation: Prepare a 10 μ M stock solution of the fluorophore in deionized water. If the probe is highly hydrophobic, use <0.1% DMSO to initiate dissolution.
- Host Titration: Prepare a series of quartz cuvettes containing the 10 μ M probe and varying concentrations of β -CD ranging from 0.0 mM to 8.0 mM.

- Causality: Titrating the host allows for the stepwise observation of binding kinetics. Lower concentrations favor a 1:1 inclusion complex, while higher concentrations force a 1:2 (probe:host) complex, progressively shielding the probe from the aqueous environment[2].
- Lifetime Acquisition: Excite the samples using a pulsed laser diode (e.g., 375 nm) and collect the emission at the probe's solvatochromic λ_{max} .
- Kinetic Fitting & Self-Validation:
 - Fit the decay profiles to exponential models.
 - Self-Validating Step: Evaluate the reduced χ^2 value of the fit. A χ^2 value near unity (0.99–1.15) confirms that the chosen mono- or bi-exponential decay model accurately represents the photophysical relaxation of the probe without instrumental artifact[2].
- Steady-State Anisotropy (r_{ss}): Measure the fluorescence anisotropy across the titration gradient.
 - Causality: As the probe is encapsulated within the rigid cyclodextrin cavity, its rotational diffusion is severely restricted. This physical restriction prevents the molecule from tumbling during its excited state lifetime, resulting in a measurable increase in anisotropy values[2]. A biphasic slope in the anisotropy graph confirms the transition from a 1:1 to a 1:2 binding stoichiometry[2].

References

- Probing the spectral response of a new class of bioactive pyrazoline derivative in homogeneous solvents and cyclodextrin nanocavities: a spectroscopic exploration appended by quantum chemical calculations and molecular docking analysis Source: rsc.org URL: [\[Link\]](#)[1]
- Recent Advances in Synthesis and Properties of Pyrazoles Source: mdpi.com URL: [\[Link\]](#)[3]
- NaCl: a facile, environmentally benign catalyst for the synthesis of pyrazole 4-carbonitrile in aqueous media Source: researchgate.net URL: [\[Link\]](#)[7]

- Development of New Thiazole Complexes as Powerful Catalysts for Synthesis of Pyrazole-4-Carbonitrile Derivatives under Ultrasonic Irradiation Condition Supported by DFT Studies
Source: acs.org URL:[Link][5]
- (a) Variation of the time-resolved fluorescence decay profile of PZ in the presence of the b
Source: researchgate.net URL:[Link][2]
- Facile Synthesis and Antimicrobial Activities of Novel 1,4-Bis(3,5-dialkyl-4H-1,2,4-triazol-4-yl)benzene and 5-Aryltriaz-1-en-1-yl-1-phenyl-1H-pyrazole-4-carbonitrile Derivatives Source: acs.org URL:[Link][4]
- Development of New Thiazole Complexes as Powerful Catalysts for Synthesis of Pyrazole-4-Carbonitrile Derivatives under Ultrasonic Irradiation Condition Supported by DFT Studies
Source: nih.gov URL:[Link][6]
- H3PO4 catalyzed one-pot synthesis of 1,3-diphenyl-1H-pyrazole-4 Source: ias.ac.in URL: [Link][8]

Need Custom Synthesis?

BenchChem offers custom synthesis for rare earth carbides and specific isotopic labeling.

Email: info@benchchem.com or [Request Quote Online](#).

Sources

- [1. Probing the spectral response of a new class of bioactive pyrazoline derivative in homogeneous solvents and cyclodextrin nanocavities: a spectroscopic exploration appended by quantum chemical calculations and molecular docking analysis - RSC Advances \(RSC Publishing\) \[pubs.rsc.org\]](#)
- [2. researchgate.net \[researchgate.net\]](#)
- [3. mdpi.com \[mdpi.com\]](#)
- [4. pubs.acs.org \[pubs.acs.org\]](#)
- [5. pubs.acs.org \[pubs.acs.org\]](#)
- [6. Development of New Thiazole Complexes as Powerful Catalysts for Synthesis of Pyrazole-4-Carbonitrile Derivatives under Ultrasonic Irradiation Condition Supported by DFT](#)

Studies - PMC [[pmc.ncbi.nlm.nih.gov](https://pubmed.ncbi.nlm.nih.gov)]

- [7. researchgate.net \[researchgate.net\]](https://www.researchgate.net)
- [8. ias.ac.in \[ias.ac.in\]](https://ias.ac.in)
- To cite this document: BenchChem. [Application Note: Engineering Pyrazole-4-Carbonitrile Fluorescent Probes for Microenvironment Sensing]. BenchChem, [2026]. [Online PDF]. Available at: [<https://www.benchchem.com/product/b8158803/docs#application-note-engineering-pyrazole-4-carbonitrile-fluorescent-probes-for-microenvironment-sensing>]

Disclaimer & Data Validity:

The information provided in this document is for Research Use Only (RUO) and is strictly not intended for diagnostic or therapeutic procedures. While BenchChem strives to provide accurate protocols, we make no warranties, express or implied, regarding the fitness of this product for every specific experimental setup.

Technical Support: The protocols provided are for reference purposes. Unsure if this reagent suits your experiment?

Need Industrial/Bulk Grade? [Request Custom Synthesis Quote](#)

BenchChem

Our mission is to be the trusted global source of essential and advanced chemicals, empowering scientists and researchers to drive progress in science and industry.

Contact

Address: 3281 E Guasti Rd
Ontario, CA 91761, United States
Phone: (601) 213-4426
Email: info@benchchem.com

[Contact our Ph.D. Support Team for a compatibility check](#)

