

Application Notes and Protocols for the Analytical Characterization of C10 Bisphosphonates

Author: BenchChem Technical Support Team. **Date:** April 2026

Compound of Interest

Compound Name: C10 Bisphosphonate

Cat. No.: B8148480

[Get Quote](#)

For Researchers, Scientists, and Drug Development Professionals

These application notes provide detailed methodologies for the characterization of **C10 bisphosphonates**, a class of compounds investigated for their therapeutic potential in various diseases, including inflammatory lung conditions and atherosclerosis.[1] The analytical characterization of bisphosphonates presents a significant challenge due to their high polarity, strong chelation properties, and lack of strong chromophores for conventional UV detection.[2] [3][4] This document outlines several robust analytical techniques, including High-Performance Liquid Chromatography (HPLC), Ion Chromatography (IC), Mass Spectrometry (MS), Nuclear Magnetic Resonance (NMR) Spectroscopy, and Capillary Electrophoresis (CE), to address these challenges and ensure accurate and reliable characterization.

The general structure of bisphosphonates consists of a central carbon atom bonded to two phosphonate groups (P-C-P backbone).[5] This P-C-P moiety is crucial for their strong affinity for bone mineral. The two side chains on the central carbon, often denoted as R1 and R2, determine the compound's pharmacological properties. For **C10 bisphosphonates**, one of these side chains is a ten-carbon alkyl chain.

General structure of a bisphosphonate molecule.

High-Performance Liquid Chromatography (HPLC) Application Note

High-Performance Liquid Chromatography (HPLC) is a cornerstone technique for the analysis of bisphosphonates. Due to their high polarity and lack of a strong UV chromophore, direct analysis by reversed-phase HPLC is challenging. To overcome these issues, several strategies are employed:

- **Ion-Pair Reversed-Phase HPLC (IP-RP-HPLC):** This is a common approach where an ion-pairing agent, such as n-amylamine or tetrabutylammonium chloride, is added to the mobile phase. The ion-pairing agent forms a neutral complex with the anionic bisphosphonate, allowing for retention on a non-polar stationary phase like C18.
- **Derivatization:** To enhance detection sensitivity, derivatization of the bisphosphonate molecule can be performed. For nitrogen-containing bisphosphonates, the primary amine group can be derivatized post-column with reagents like o-phthalaldehyde (OPA) to yield a fluorescent product. Pre-column derivatization with reagents like trimethylsilyldiazomethane can also be used, especially for LC-MS analysis, to make the molecule less polar.
- **Hydrophilic Interaction Liquid Chromatography (HILIC):** HILIC is an alternative chromatographic mode that uses a polar stationary phase and a mobile phase with a high concentration of an organic solvent. This technique is well-suited for the separation of highly polar compounds like bisphosphonates without the need for derivatization.
- **Detection:** Given the lack of a native chromophore, detection can be achieved by several means:
 - **Indirect UV Detection:** A UV-absorbing component is added to the mobile phase. When the non-absorbing analyte elutes, it causes a decrease in absorbance, which is detected as a negative peak.
 - **Evaporative Light Scattering Detection (ELSD):** This universal detection method is suitable for non-volatile analytes and does not require a chromophore.

- Charged Aerosol Detection (CAD): Another universal detection method that can be used for the analysis of bisphosphonates.
- Mass Spectrometry (MS): Coupling HPLC with MS provides high sensitivity and selectivity.

This section provides a protocol for an ion-pair reversed-phase HPLC method with UV detection, a widely accessible and robust method for quantitative analysis in pharmaceutical formulations.

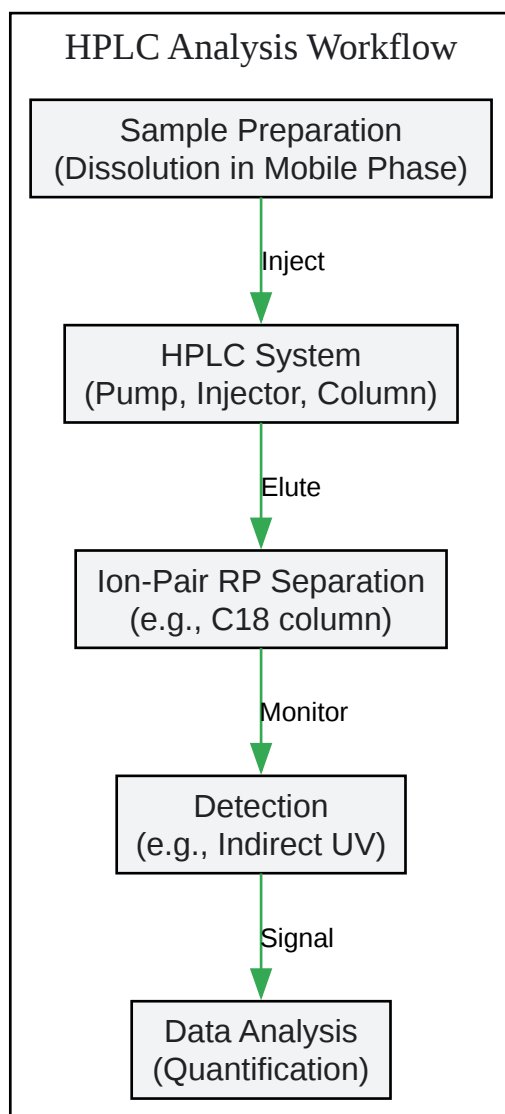

[Click to download full resolution via product page](#)

Workflow for HPLC analysis of **C10 bisphosphonates**.

Experimental Protocol: Ion-Pair RP-HPLC with Indirect UV Detection

This protocol is adapted from methodologies developed for various bisphosphonates and is suitable for the quantification of **C10 bisphosphonates** in pharmaceutical formulations.

- Instrumentation:
 - HPLC system with a gradient or isocratic pump, autosampler, column oven, and UV-Vis detector.
 - C18 analytical column (e.g., 250 mm x 4.6 mm, 5 µm particle size).
- Reagents and Solutions:
 - Mobile Phase: Prepare a mobile phase consisting of a mixture of a borate buffer (50 mM, pH 9.0) containing tetrabutylammonium chloride (0.25 mM) and EDTA (0.5 mM), and acetonitrile (e.g., 97:3 v/v). The mobile phase also acts as the diluent for standards and samples.
 - Standard Solutions: Prepare a stock solution of the **C10 bisphosphonate** reference standard in the mobile phase. Prepare a series of working standard solutions by diluting the stock solution to cover the desired concentration range (e.g., 20-120 µg/mL).
 - Sample Preparation: For a tablet formulation, accurately weigh and powder a sufficient number of tablets. Transfer an amount of powder equivalent to a target concentration of the **C10 bisphosphonate** into a volumetric flask. Add the mobile phase, sonicate to dissolve, and dilute to volume. Filter the solution through a 0.45 µm filter before injection.
- Chromatographic Conditions:
 - Flow Rate: 1.0 mL/min.
 - Column Temperature: 30 °C.
 - Injection Volume: 20 µL.

- Detection: Indirect UV detection at a wavelength where the mobile phase additive absorbs (e.g., 240 nm or 210 nm).
- Analysis:
 - Inject the standard solutions to construct a calibration curve by plotting the peak area against the concentration.
 - Inject the sample solutions.
 - Quantify the amount of **C10 bisphosphonate** in the sample by comparing its peak area to the calibration curve.

Quantitative Data Summary

Parameter	Value / Condition	References
Technique	Ion-Pair Reversed-Phase HPLC	
Column	C18, 250 mm x 4.6 mm, 5 µm	
Mobile Phase	50 mM borate buffer (pH 9.0) with 0.25 mM tetrabutylammonium chloride, 0.5 mM EDTA, and Acetonitrile (97:3 v/v)	
Flow Rate	1.0 mL/min	
Temperature	30 °C	
Detection	Indirect UV at 210-240 nm	
Injection Volume	20 - 30 µL	
Linearity Range	Typically 20 - 120 µg/mL	
LOD	~0.4 µg/mL	

Ion Chromatography (IC)

Application Note

Ion Chromatography (IC) is a highly effective technique for the direct analysis of bisphosphonates. Its suitability stems from the ionic nature of these compounds. The separation is based on the interaction of the anionic phosphonate groups with a positively charged stationary phase (anion-exchange column).

Key advantages of IC for bisphosphonate analysis include:

- **Direct Analysis:** Often, no derivatization is required, simplifying sample preparation.
- **High Selectivity:** The use of anion-exchange columns provides excellent selectivity for these highly polar anions.
- **Compatibility with Mass Spectrometry:** IC systems can be readily coupled with mass spectrometry (IC-MS), offering superior sensitivity and specificity, which is particularly useful for analysis in complex matrices. The eluent from the IC system is often compatible with MS ionization sources.

Detection in IC can be achieved through:

- **Suppressed Conductivity Detection:** A common detection method in IC that provides high sensitivity for ionic analytes.
- **Indirect UV Detection:** Similar to HPLC, a UV-absorbing eluent is used, and the analyte is detected as a negative peak.
- **Inductively Coupled Plasma Mass Spectrometry (ICP-MS):** This can be used to detect phosphorus-containing compounds with high sensitivity.

This section provides a protocol for an IC-MS method, which represents a state-of-the-art approach for the sensitive and selective analysis of bisphosphonates.

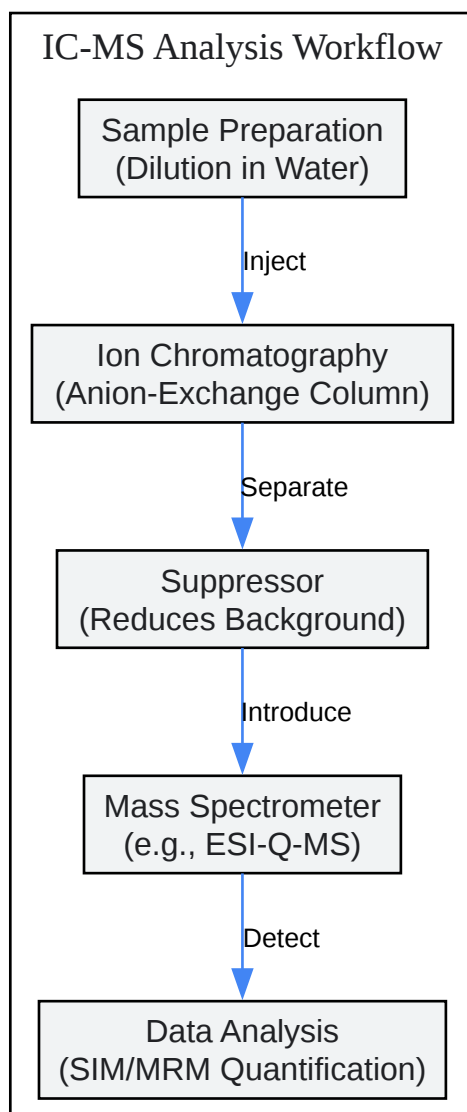

[Click to download full resolution via product page](#)

Workflow for IC-MS analysis of **C10 bisphosphonates**.

Experimental Protocol: IC-MS

This protocol is based on established methods for the analysis of nitrogen-containing bisphosphonates without derivatization.

- Instrumentation:
 - High-performance ion chromatography (HPIC) system.

- Anion-exchange column (e.g., Thermo Scientific™ Dionex™ IonPac™ AS18).
- Suppressor (e.g., Thermo Scientific™ Dionex™ AERS™ 500).
- Single quadrupole or tandem mass spectrometer with a heated electrospray ionization (HESI) source.
- Reagents and Solutions:
 - Eluent: Use an eluent gradient generated by the IC system, typically with potassium hydroxide (KOH).
 - Standard Solutions: Prepare a stock solution of the **C10 bisphosphonate** in deionized water. Prepare working standards by serial dilution to achieve concentrations in the ng/μL range (e.g., 0.01 to 1 ng/μL).
 - Sample Preparation: Dilute the sample containing the **C10 bisphosphonate** in deionized water to fall within the calibration range.
- Chromatographic and MS Conditions:
 - Column: Dionex IonPac AS18, 4 μm.
 - Eluent Gradient: A typical gradient could be from a low to a high concentration of KOH over approximately 15 minutes to elute the bisphosphonates.
 - Flow Rate: 0.25 mL/min.
 - Column Temperature: 30 °C.
 - Injection Volume: 5 μL.
 - MS Ionization: HESI in negative ion mode.
 - MS Detection: Selected Ion Monitoring (SIM) mode, monitoring the [M-H]⁻ ion of the **C10 bisphosphonate**.
- Analysis:

- Generate a calibration curve from the standard solutions. Linearity is typically observed in the low ng/μL range.
- Analyze the samples and quantify the **C10 bisphosphonate** using the calibration curve. The high selectivity of MS allows for accurate quantification even in complex matrices.

Quantitative Data Summary

Parameter	Value / Condition	References
Technique	Ion Chromatography - Mass Spectrometry (IC-MS)	
Column	Thermo Scientific™ Dionex™ IonPac™ AS18, 4 μm	
Eluent	Potassium Hydroxide (KOH) gradient	
Flow Rate	0.25 mL/min	
Temperature	30 °C	
Detection	Single Quadrupole MS with HESI (Negative SIM mode)	
Injection Volume	5 μL	
Linearity Range	0.01 - 1 ng/μL (10 - 1000 ng/mL)	
LOD/LOQ	Low ng/mL range	

Nuclear Magnetic Resonance (NMR) Spectroscopy Application Note

Nuclear Magnetic Resonance (NMR) spectroscopy is a powerful tool for the unambiguous structural elucidation and characterization of bisphosphonates. It provides detailed information about the molecular structure, including the carbon skeleton, the phosphonate groups, and their connectivity.

- ^{31}P NMR: This is a key technique for bisphosphonate characterization. The phosphorus atoms in the two phosphonate groups are magnetically active, and ^{31}P NMR provides direct evidence for the P-C-P backbone. The chemical shifts and coupling constants can provide information about the chemical environment of the phosphorus nuclei.
- ^1H NMR: Proton NMR is used to characterize the organic part of the molecule, including the C10 alkyl chain. The chemical shifts, signal integrations, and coupling patterns help to confirm the structure of the R-groups attached to the central carbon.
- ^{13}C NMR: Carbon NMR provides information about the carbon framework of the molecule. The P-C coupling can be observed, which further confirms the structure.
- Quantitative NMR (qNMR): ^1H -NMR can also be used for quantitative analysis by integrating the signal of the analyte against a certified internal standard. This method is highly accurate and does not require a reference standard of the analyte itself.

NMR is particularly valuable for confirming the identity of a newly synthesized **C10 bisphosphonate** and for identifying impurities and degradation products.

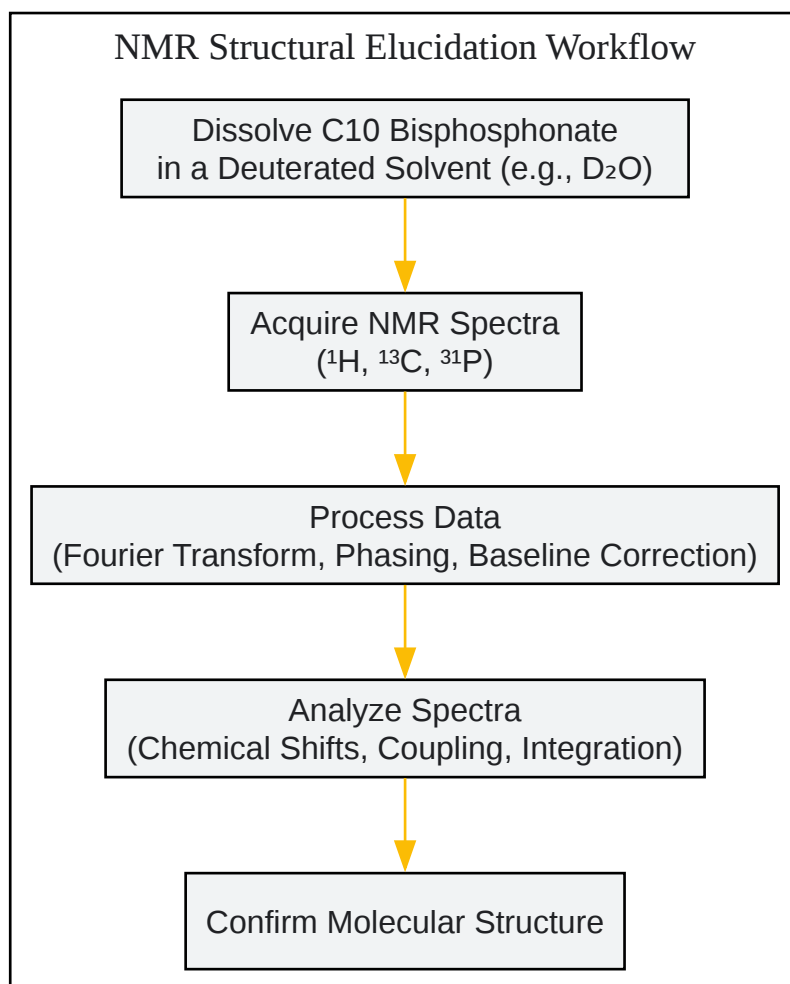

[Click to download full resolution via product page](#)

Workflow for NMR-based structural characterization.

Experimental Protocol: Structural Characterization by NMR

- Instrumentation:
 - High-resolution NMR spectrometer (e.g., 400 MHz or higher).
- Sample Preparation:
 - Accurately weigh approximately 5-10 mg of the **C10 bisphosphonate** sample.

- Dissolve the sample in a suitable deuterated solvent (e.g., 0.6 mL of D₂O). The choice of solvent may depend on the solubility of the specific **C10 bisphosphonate**.
- NMR Data Acquisition:
 - ¹H NMR: Acquire a standard one-dimensional proton spectrum. Typical parameters include a 90° pulse, a relaxation delay of 1-5 seconds, and a sufficient number of scans to achieve a good signal-to-noise ratio.
 - ³¹P NMR: Acquire a proton-decoupled phosphorus spectrum. 85% H₃PO₄ is used as an external reference.
 - ¹³C NMR: Acquire a proton-decoupled carbon spectrum. A larger number of scans will be required compared to ¹H NMR due to the lower natural abundance of ¹³C.
 - 2D NMR (Optional): For complete structural assignment, 2D NMR experiments such as COSY (¹H-¹H correlation), HSQC (¹H-¹³C correlation), and HMBC (long-range ¹H-¹³C correlation) can be performed.
- Data Analysis:
 - Process the acquired data using appropriate software (e.g., MestReNova, TopSpin). This includes Fourier transformation, phase correction, baseline correction, and referencing.
 - Integrate the peaks in the ¹H spectrum to determine the relative number of protons.
 - Analyze the chemical shifts and coupling constants in all spectra to assign the signals to the respective nuclei in the **C10 bisphosphonate** structure.
 - Confirm the presence of the P-C-P backbone from the ³¹P NMR spectrum and P-C coupling in the ¹³C spectrum.

Expected NMR Data

Nucleus	Expected Chemical Shift Range (ppm)	Information Provided
¹ H	0.8 - 4.0	Structure of the alkyl chain and other organic moieties.
¹³ C	10 - 80	Carbon skeleton, presence of P-C coupling.
³¹ P	15 - 25	Confirmation of the P-C-P backbone, chemical environment of phosphonate groups.

Note: The exact chemical shifts will depend on the specific structure of the **C10 bisphosphonate** and the solvent used.

Capillary Electrophoresis (CE)

Application Note

Capillary Electrophoresis (CE) is a high-resolution separation technique that is well-suited for the analysis of charged species like bisphosphonates. The separation is based on the differential migration of analytes in an electric field within a narrow-bore capillary.

Key features of CE for bisphosphonate analysis:

- **High Efficiency:** CE provides very high separation efficiency, allowing for the resolution of closely related compounds.
- **Minimal Sample Consumption:** Only nanoliter volumes of sample are required for injection.
- **Direct Analysis:** Derivatization is often not necessary, especially when using direct UV detection at low wavelengths (around 190-210 nm) where the phosphonate groups exhibit some absorbance.

The most common mode of CE for this application is Capillary Zone Electrophoresis (CZE). In CZE, the separation occurs in a capillary filled with a buffer solution, and the analytes are

separated based on their charge-to-mass ratio.

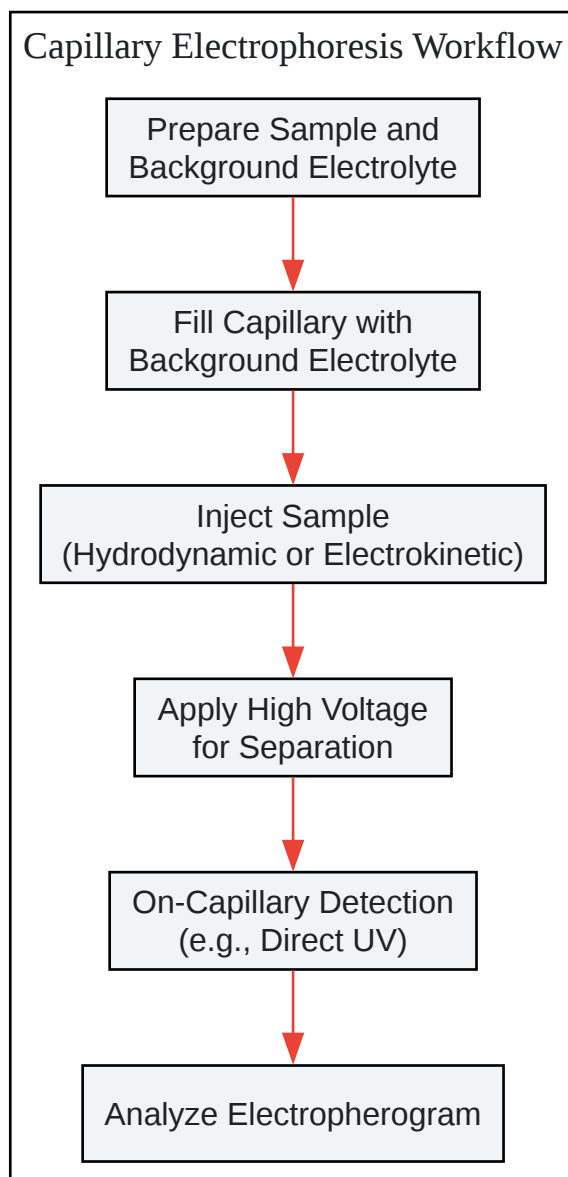

[Click to download full resolution via product page](#)

Workflow for Capillary Electrophoresis analysis.

Experimental Protocol: Capillary Zone Electrophoresis (CZE)

This protocol is based on methods developed for the analysis of bisphosphonates in pharmaceutical dosage forms.

- Instrumentation:
 - Capillary electrophoresis system equipped with a UV detector.
 - Uncoated or coated fused-silica capillary (e.g., 50 μm I.D., ~50 cm total length). Polyacrylamide-coated capillaries can be used to reduce analyte-wall interactions.
- Reagents and Solutions:
 - Background Electrolyte (BGE): A phosphate buffer (e.g., 25 mM, pH 7.0) is a common choice. The pH and ionic strength of the BGE are critical parameters affecting the separation.
 - Standard Solutions: Prepare a stock solution of the **C10 bisphosphonate** in the BGE or water. Prepare working standards by dilution.
 - Sample Preparation: Dilute the sample in the BGE to a suitable concentration.
- CE Conditions:
 - Capillary Conditioning: Before the first use, and daily, rinse the capillary with 0.1 M NaOH, water, and then the BGE.
 - Injection: Hydrodynamic injection (e.g., by applying pressure for a few seconds) or electrokinetic injection.
 - Separation Voltage: Apply a voltage in the range of 15-25 kV. The polarity will depend on the charge of the analyte and the direction of the electroosmotic flow. For anionic bisphosphonates, reversed polarity is often used.
 - Temperature: Maintain the capillary at a constant temperature (e.g., 25 $^{\circ}\text{C}$).
 - Detection: Direct UV detection at a low wavelength (e.g., 200 nm).
- Analysis:
 - Analyze the electropherograms to determine the migration time and peak area of the **C10 bisphosphonate**.

- Quantify the analyte using a calibration curve constructed from the standard solutions.

Quantitative Data Summary

Parameter	Value / Condition	References
Technique	Capillary Zone Electrophoresis (CZE)	
Capillary	Fused-silica, e.g., 50 μm I.D., 50 cm length (coated or uncoated)	
Background Electrolyte	Phosphate buffer (e.g., 25 mM, pH 7.0)	
Separation Voltage	15 - 25 kV (often with reversed polarity)	
Temperature	25 $^{\circ}\text{C}$	-
Detection	Direct UV at ~ 200 nm	
LOD	50 ng/mL to 30 $\mu\text{g/mL}$ (highly method-dependent)	

Conclusion

The characterization of **C10 bisphosphonates** requires a suite of analytical techniques to confirm identity, purity, and quantity. HPLC and IC are workhorse methods for quantification in pharmaceutical formulations, with IC-MS providing the highest sensitivity and selectivity. NMR spectroscopy is indispensable for definitive structural elucidation. Capillary electrophoresis offers a high-efficiency orthogonal separation technique. The choice of method will depend on the specific analytical challenge, whether it is routine quality control, structural confirmation of a new chemical entity, or analysis in a complex biological matrix. The protocols and data presented here provide a comprehensive guide for researchers, scientists, and drug development professionals working with this important class of compounds.

Need Custom Synthesis?

BenchChem offers custom synthesis for rare earth carbides and specific isotopic labeling.

Email: info@benchchem.com or [Request Quote Online](#).

References

- [1. avantiresearch.com \[avantiresearch.com\]](http://1.avantiresearch.com)
- [2. lcms.cz \[lcms.cz\]](http://2.lcms.cz)
- [3. Quantification of Low Amounts of Zoledronic Acid by HPLC-ESI-MS Analysis: Method Development and Validation | MDPI \[mdpi.com\]](#)
- [4. A general approach for the quantitative analysis of bisphosphonates in human serum and urine by high-performance liquid chromatography/tandem mass spectrometry - PubMed \[pubmed.ncbi.nlm.nih.gov\]](#)
- [5. Bisphosphonates: structure-activity relations from a clinical perspective - PubMed \[pubmed.ncbi.nlm.nih.gov\]](#)
- To cite this document: BenchChem. [Application Notes and Protocols for the Analytical Characterization of C10 Bisphosphonates]. BenchChem, [2026]. [Online PDF]. Available at: [\[https://www.benchchem.com/product/b8148480/docs#application-notes-and-protocols-for-the-analytical-characterization-of-c10-bisphosphonates\]](https://www.benchchem.com/product/b8148480/docs#application-notes-and-protocols-for-the-analytical-characterization-of-c10-bisphosphonates)

Disclaimer & Data Validity:

The information provided in this document is for Research Use Only (RUO) and is strictly not intended for diagnostic or therapeutic procedures. While BenchChem strives to provide accurate protocols, we make no warranties, express or implied, regarding the fitness of this product for every specific experimental setup.

Technical Support: The protocols provided are for reference purposes. Unsure if this reagent suits your experiment?

Need Industrial/Bulk Grade? [Request Custom Synthesis Quote](#)

BenchChem

Our mission is to be the trusted global source of essential and advanced chemicals, empowering scientists and researchers to drive progress in science and industry.

Contact

Address: 3281 E Guasti Rd

Ontario, CA 91761, United States

Phone: (601) 213-4426

Email: info@benchchem.com

[Contact our Ph.D. Support Team for a compatibility check](#)