

Application Notes and Protocols: Scale-up Synthesis of Cyclobutylalanine Derivatives

Author: BenchChem Technical Support Team. **Date:** April 2026

Compound of Interest

Compound Name: (S)-tert-Butyl 2-amino-3-cyclobutylpropanoate

Cat. No.: B8147614

[Get Quote](#)

Introduction

Unnatural amino acids (UAAs) are pivotal in modern drug discovery and development, offering a means to enhance the pharmacological properties of peptides and small molecules.^{[1][2][3]} Among these, cyclobutylalanine derivatives have garnered significant interest due to their unique conformational constraints, which can improve metabolic stability, binding affinity, and bioavailability of parent compounds.^{[4][5][6][7]} The cyclobutane moiety, a four-membered carbocyclic ring, imparts a degree of rigidity that is synthetically useful.^{[8][9]}

The transition from small-scale laboratory synthesis to large-scale production presents numerous challenges, including cost, safety, and process reproducibility.^{[10][11]} This guide provides a comprehensive overview of scalable synthetic strategies for cyclobutylalanine derivatives, focusing on practical, field-proven protocols and the underlying chemical principles. We will explore key synthetic methodologies, address common scale-up challenges, and provide detailed experimental procedures for researchers, scientists, and drug development professionals.

Key Synthetic Strategies for Scale-Up

The synthesis of cyclobutylalanine derivatives on a large scale necessitates careful consideration of starting materials, reaction efficiency, and purification methods. Two predominant strategies have emerged as robust and scalable: Reductive Amination of Cyclobutyl Ketones and [2+2] Cycloaddition Reactions.

Reductive Amination of Cyclobutyl Ketones

Reductive amination is a widely employed and highly versatile method for the synthesis of amines, making it a cornerstone for the large-scale production of cyclobutylalanine.[12][13][14] This one-pot reaction typically involves the formation of an imine or enamine intermediate from a ketone and an amine, followed by in-situ reduction.

Causality Behind Experimental Choices:

- **Starting Material:** Cyclobutanone and its derivatives are readily available and serve as excellent starting points for this strategy.[8] The choice of the amine component (e.g., ammonia, a primary amine, or an amino acid ester) determines the final product.
- **Reducing Agent:** The selection of the reducing agent is critical for both efficiency and safety on a larger scale. While sodium borohydride (NaBH_4) is effective, sodium triacetoxyborohydride ($\text{NaBH}(\text{OAc})_3$) and sodium cyanoborohydride (NaBH_3CN) are often preferred for their milder nature and selectivity for the iminium ion over the ketone, minimizing side reactions.[12][13] For industrial applications, catalytic hydrogenation offers a greener and more cost-effective alternative.
- **Solvent and Catalyst:** The choice of solvent impacts reaction kinetics and solubility. Dichloroethane (DCE) is a common choice, and the addition of a mild acid catalyst, such as acetic acid, can facilitate imine formation.[12]

Workflow Diagram: Reductive Amination

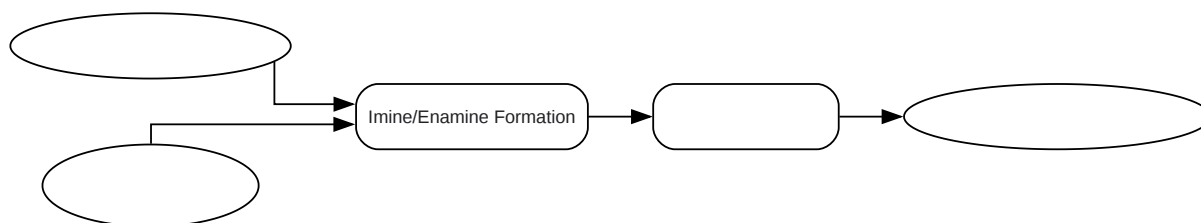

[Click to download full resolution via product page](#)

Caption: Reductive amination workflow for cyclobutylalanine synthesis.

[2+2] Cycloaddition Reactions

[2+2] cycloaddition reactions provide a powerful and stereocontrolled route to cyclobutane rings.[9][15] This strategy is particularly valuable for accessing enantiomerically pure cyclobutylalanine derivatives when chiral catalysts or auxiliaries are employed.[16][17]

Causality Behind Experimental Choices:

- **Reactants:** The reaction typically involves an electron-rich alkene (donor) and an electron-poor alkene (acceptor). For the synthesis of cyclobutane α -amino acids, 2-(acylamino)acrylates can serve as the acceptor alkene, reacting with a suitable vinyl donor.
- **Catalysis:** The use of Lewis acids or transition metal catalysts is often necessary to promote the cycloaddition and control stereoselectivity. Chiral catalysts are instrumental in achieving high enantiomeric excess, which is crucial for pharmaceutical applications.[18][19][20]
- **Reaction Conditions:** Careful optimization of solvent, temperature, and catalyst loading is essential for achieving high yields and selectivities, especially during scale-up.

Workflow Diagram: [2+2] Cycloaddition

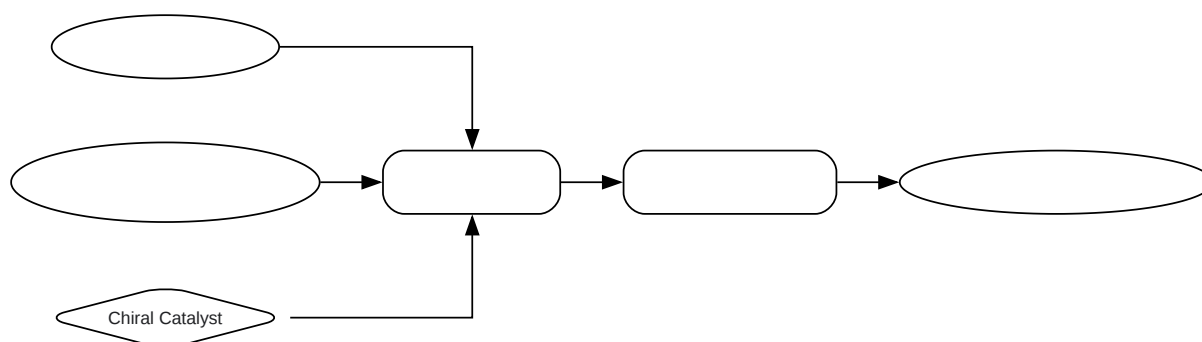

[Click to download full resolution via product page](#)

Caption: Asymmetric [2+2] cycloaddition for enantioselective synthesis.

Scale-Up Considerations and Challenges

Transitioning a synthetic route from the laboratory bench to a pilot or manufacturing scale introduces a new set of challenges that must be addressed to ensure a safe, efficient, and reproducible process.^{[10][11][21]}

Challenge	Mitigation Strategy
Exothermic Reactions	Controlled addition of reagents, efficient heat exchange systems, and careful monitoring of reaction temperature are crucial. For highly exothermic reactions, a semi-batch or continuous flow process may be preferable. ^[22]
Reagent Cost and Availability	For large-scale synthesis, it is imperative to select reagents that are cost-effective and readily available in bulk quantities. ^[10]
Work-up and Purification	Extraction and chromatography techniques that are feasible on a small scale may become impractical and costly at larger scales. Crystallization is often the preferred method for purification on an industrial scale due to its efficiency and cost-effectiveness.
Safety and Handling	A thorough safety assessment of all reagents, intermediates, and reaction conditions is mandatory. This includes understanding potential hazards such as toxicity, flammability, and reactivity.
Process Reproducibility	Establishing robust process parameters and in-process controls (IPCs) is essential to ensure consistent product quality across different batches.

Detailed Protocols

Protocol 1: Scale-Up Synthesis of (±)-1-Aminocyclobutane-1-carboxylic Acid via Reductive Amination

This protocol describes a scalable synthesis of racemic 1-aminocyclobutane-1-carboxylic acid from cyclobutanone.

Materials:

- Cyclobutanone
- Ammonium acetate
- Sodium cyanide
- Methanol
- Hydrochloric acid (concentrated)
- Sodium hydroxide
- Diethyl ether

Procedure:

- **Reaction Setup:** To a 2 L three-necked round-bottom flask equipped with a mechanical stirrer, thermometer, and addition funnel, add cyclobutanone (1.0 mol) and ammonium acetate (1.5 mol) in methanol (500 mL).
- **Cyanide Addition:** Cool the mixture to 0-5 °C in an ice bath. Slowly add a solution of sodium cyanide (1.2 mol) in water (200 mL) via the addition funnel, maintaining the temperature below 10 °C.
- **Reaction Monitoring:** Stir the reaction mixture at room temperature for 12-16 hours. Monitor the reaction progress by TLC or HPLC until the starting material is consumed.

- Hydrolysis: Carefully add concentrated hydrochloric acid (500 mL) to the reaction mixture and heat to reflux for 6-8 hours.
- Work-up and Isolation: Cool the reaction mixture to room temperature and neutralize with a 50% aqueous solution of sodium hydroxide to pH 6-7. The product will precipitate out of the solution.
- Purification: Filter the solid product, wash with cold water and then diethyl ether. Dry the product under vacuum to yield (\pm)-1-aminocyclobutane-1-carboxylic acid.

Protocol 2: Asymmetric Synthesis of a Protected Cyclobutylalanine Derivative via [2+2] Cycloaddition

This protocol outlines a general approach for the enantioselective synthesis of a cyclobutylalanine derivative using a chiral catalyst.

Materials:

- N-Boc-dehydroalanine methyl ester
- Vinyl ether
- Chiral Lewis acid catalyst (e.g., a chiral copper or nickel complex)
- Dichloromethane (DCM)
- Silica gel for chromatography

Procedure:

- Reaction Setup: In a flame-dried, inert atmosphere (e.g., argon or nitrogen) reactor, dissolve the chiral Lewis acid catalyst (0.05 mol%) in anhydrous DCM (1 L).
- Substrate Addition: Add N-Boc-dehydroalanine methyl ester (1.0 mol) to the catalyst solution and stir for 15 minutes.
- Cycloaddition: Slowly add the vinyl ether (1.2 mol) to the reaction mixture at the optimized temperature (e.g., -20 °C) over 2-3 hours.

- **Reaction Monitoring:** Monitor the reaction for completion by TLC or HPLC.
- **Quenching and Work-up:** Once the reaction is complete, quench with a saturated aqueous solution of ammonium chloride. Separate the organic layer, wash with brine, and dry over anhydrous sodium sulfate.
- **Purification:** Concentrate the organic layer under reduced pressure and purify the crude product by flash column chromatography on silica gel to afford the enantiomerically enriched protected cyclobutylalanine derivative.

Characterization and Quality Control

Rigorous analytical testing is essential to ensure the identity, purity, and quality of the final cyclobutylalanine derivative.

Analytical Technique	Purpose
Nuclear Magnetic Resonance (NMR)	Structural elucidation and confirmation of the desired product.
High-Performance Liquid Chromatography (HPLC)	Determination of purity and enantiomeric excess (using a chiral column).
Mass Spectrometry (MS)	Confirmation of the molecular weight of the product.
Infrared (IR) Spectroscopy	Identification of key functional groups.
Elemental Analysis	Determination of the elemental composition of the product.

Conclusion

The scale-up synthesis of cyclobutylalanine derivatives is a critical step in advancing their application in pharmaceutical development. The choice of synthetic strategy, careful process optimization, and robust analytical characterization are paramount for a successful and efficient manufacturing process. The protocols and considerations outlined in this guide provide a solid foundation for researchers and drug development professionals to navigate the complexities of large-scale synthesis and unlock the full potential of these valuable unnatural amino acids. The

continued development of novel and efficient synthetic methodologies, including biocatalytic approaches, will further enhance the accessibility and utility of cyclobutylalanine derivatives in the future.[23][24][25]

References

- University of California, Irvine. (n.d.). Large-scale Library Generation of Unnatural Amino Acid Biosynthetic Enzymes. Retrieved from [\[Link\]](#)
- ResearchGate. (2000). ChemInform Abstract: The Large-Scale Synthesis of Unnatural Amino Acids. Retrieved from [\[Link\]](#)
- Royal Society of Chemistry. (2015). Rapid and scalable synthesis of innovative unnatural α,β or γ -amino acids functionalized with tertiary amines on their side-chains. *Organic & Biomolecular Chemistry*. DOI: 10.1039/C5OB00828J. Retrieved from [\[Link\]](#)
- PubMed. (2000). The large scale synthesis of "unnatural" amino acids. Retrieved from [\[Link\]](#)
- Loyola eCommons. (2008). Synthesis of Substituted 2-Amino-Cyclobutanones. Retrieved from [\[Link\]](#)
- Semantic Scholar. (n.d.). Catalytic asymmetric synthesis of spirocyclobutyl oxindoles and beyond via [2+2] cycloaddition and sequential transformations. Retrieved from [\[Link\]](#)
- National Institutes of Health. (n.d.). Stereocontrolled Synthesis and Functionalization of Cyclobutanes and Cyclobutanones. Retrieved from [\[Link\]](#)
- ResearchGate. (n.d.). Large-scale reductive amination and synthesis applications. Retrieved from [\[Link\]](#)
- Thieme. (n.d.). Formal [2+2] Cycloaddition of 2-(Acylamino)acrylates with Vinyl Sulfides: An Approach to Cyclobutane α -Amino Acids as S-Phenylcysteine Analogues. Retrieved from [\[Link\]](#)
- National Institutes of Health. (n.d.). Catalytic Enantioselective Synthesis of Cyclobutenes from Alkynes and Alkenyl Derivatives. Retrieved from [\[Link\]](#)

- Prime Scholars. (2021). How to deal with Scale-up challenges of Chemistry?. Retrieved from [\[Link\]](#)
- Organic Chemistry Portal. (n.d.). Amine synthesis by reductive amination (reductive alkylation). Retrieved from [\[Link\]](#)
- Master Organic Chemistry. (2017). Reductive Amination, and How It Works. Retrieved from [\[Link\]](#)
- ResearchGate. (n.d.). Formal γ -C-H Functionalization of Cyclobutyl Ketones: Synthesis of cis-1,3-Difunctionalized Cyclobutanes. Retrieved from [\[Link\]](#)
- National Institutes of Health. (n.d.). Formal γ -C-H Functionalization of Cyclobutyl Ketones: Synthesis of cis-1,3-Difunctionalized Cyclobutanes. Retrieved from [\[Link\]](#)
- Google Patents. (n.d.). Amino acids containing a cyclobutane ring.
- National Institutes of Health. (n.d.). Quantifying Reductive Amination in Nonenzymatic Amino Acid Synthesis. Retrieved from [\[Link\]](#)
- MDPI. (2023). A Brief Review: Advancement in the Synthesis of Amine through the Leuckart Reaction. Retrieved from [\[Link\]](#)
- Royal Society of Chemistry. (n.d.). Asymmetric synthesis of chiral β -alkynyl carbonyl and sulfonyl derivatives via sequential palladium and copper catalysis. Retrieved from [\[Link\]](#)
- ResearchGate. (n.d.). Asymmetric Synthesis of Derivatives of Alanine via Michael Addition Reaction and their Biological Study. Retrieved from [\[Link\]](#)
- ResearchGate. (n.d.). Large-scale synthesis of N-protected α -amino-L-alanine derivatives. Retrieved from [\[Link\]](#)
- University of Illinois at Urbana-Champaign. (n.d.). Biocatalysis for the synthesis of pharmaceuticals and pharmaceutical intermediates. Retrieved from [\[Link\]](#)
- MDPI. (2023). Asymmetric Synthesis of US-FDA Approved Drugs over Five Years (2016–2020): A Recapitulation of Chirality. Retrieved from [\[Link\]](#)

- National Institutes of Health. (n.d.). Special Issue: Asymmetric Synthesis 2017. Retrieved from [\[Link\]](#)
- Pure Synth. (2019). Challenges of scaling up production from grams to kilos. Retrieved from [\[Link\]](#)
- ResearchGate. (2016). High yield synthesis of heterocyclic β -substituted alanine derivatives. Retrieved from [\[Link\]](#)
- National Institutes of Health. (2024). Synthesis and interest in medicinal chemistry of β -phenylalanine derivatives (β -PAD): an update (2010–2022). Retrieved from [\[Link\]](#)
- ResearchGate. (2000). ChemInform Abstract: Synthesis of β -Substituted Alanines via Michael Addition of Nucleophiles to Dehydroalanine Derivatives. Retrieved from [\[Link\]](#)
- Lab Manager. (2022). Overcoming Key Challenges in Drug Discovery. Retrieved from [\[Link\]](#)
- Pharmaceutical Technology. (2026). Meeting Challenges in Asymmetric Synthesis. Retrieved from [\[Link\]](#)
- BioInsights. (2025). Addressing challenges in AAV manufacturing scale-up for cost-effective gene therapies. Retrieved from [\[Link\]](#)

Need Custom Synthesis?

BenchChem offers custom synthesis for rare earth carbides and specific isotopic labeling.

Email: info@benchchem.com or [Request Quote Online](#).

Sources

1. cdr.lib.unc.edu [cdr.lib.unc.edu]
2. Rapid and scalable synthesis of innovative unnatural α , β or γ -amino acids functionalized with tertiary amines on their side-chains - Organic & Biomolecular Chemistry (RSC Publishing) DOI:10.1039/C5OB00828J [pubs.rsc.org]
3. Unnatural Amino Acids - Enamine [enamine.net]
4. chemimpex.com [chemimpex.com]

- [5. chemimpex.com \[chemimpex.com\]](https://chemimpex.com)
- [6. researchgate.net \[researchgate.net\]](https://researchgate.net)
- [7. Formal \$\gamma\$ -C-H Functionalization of Cyclobutyl Ketones: Synthesis of cis-1,3-Difunctionalized Cyclobutanes - PMC \[pmc.ncbi.nlm.nih.gov\]](https://pubmed.ncbi.nlm.nih.gov/35412345/)
- [8. ecommons.luc.edu \[ecommons.luc.edu\]](https://ecommons.luc.edu)
- [9. Stereocontrolled Synthesis and Functionalization of Cyclobutanes and Cyclobutanones - PMC \[pmc.ncbi.nlm.nih.gov\]](https://pubmed.ncbi.nlm.nih.gov/35412346/)
- [10. primescholars.com \[primescholars.com\]](https://primescholars.com)
- [11. pure-synth.com \[pure-synth.com\]](https://pure-synth.com)
- [12. Amine synthesis by reductive amination \(reductive alkylation\) \[organic-chemistry.org\]](https://organic-chemistry.org)
- [13. masterorganicchemistry.com \[masterorganicchemistry.com\]](https://masterorganicchemistry.com)
- [14. mdpi.com \[mdpi.com\]](https://mdpi.com)
- [15. Catalytic Enantioselective Synthesis of Cyclobutenes from Alkynes and Alkenyl Derivatives - PMC \[pmc.ncbi.nlm.nih.gov\]](https://pubmed.ncbi.nlm.nih.gov/35412347/)
- [16. pdfs.semanticscholar.org \[pdfs.semanticscholar.org\]](https://pdfs.semanticscholar.org)
- [17. Special Issue: Asymmetric Synthesis 2017 - PMC \[pmc.ncbi.nlm.nih.gov\]](https://pubmed.ncbi.nlm.nih.gov/35412348/)
- [18. Asymmetric synthesis of chiral \$\beta\$ -alkynyl carbonyl and sulfonyl derivatives via sequential palladium and copper catalysis - Chemical Science \(RSC Publishing\) \[pubs.rsc.org\]](https://pubs.rsc.org)
- [19. mdpi.com \[mdpi.com\]](https://mdpi.com)
- [20. pharmtech.com \[pharmtech.com\]](https://pharmtech.com)
- [21. Addressing challenges in AAV manufacturing scale-up for cost-effective gene therapies \[insights.bio\]](https://insights.bio)
- [22. Synthesis and interest in medicinal chemistry of \$\beta\$ -phenylalanine derivatives \(\$\beta\$ -PAD\): an update \(2010–2022\) - PMC \[pmc.ncbi.nlm.nih.gov\]](https://pubmed.ncbi.nlm.nih.gov/35412349/)
- [23. researchgate.net \[researchgate.net\]](https://researchgate.net)
- [24. The large scale synthesis of "unnatural" amino acids - PubMed \[pubmed.ncbi.nlm.nih.gov\]](https://pubmed.ncbi.nlm.nih.gov/35412350/)
- [25. zhaogroup.chbe.illinois.edu \[zhaogroup.chbe.illinois.edu\]](https://zhaogroup.chbe.illinois.edu)
- To cite this document: BenchChem. [Application Notes and Protocols: Scale-up Synthesis of Cyclobutylalanine Derivatives]. BenchChem, [2026]. [Online PDF]. Available at: [<https://www.benchchem.com/product/b8147614/docs#application-notes-and-protocols-scale-up-synthesis-of-cyclobutylalanine-derivatives>]

Disclaimer & Data Validity:

The information provided in this document is for Research Use Only (RUO) and is strictly not intended for diagnostic or therapeutic procedures. While BenchChem strives to provide accurate protocols, we make no warranties, express or implied, regarding the fitness of this product for every specific experimental setup.

Technical Support: The protocols provided are for reference purposes. Unsure if this reagent suits your experiment?

Need Industrial/Bulk Grade? [Request Custom Synthesis Quote](#)

BenchChem

Our mission is to be the trusted global source of essential and advanced chemicals, empowering scientists and researchers to drive progress in science and industry.

Contact

Address: 3281 E Guasti Rd
Ontario, CA 91761, United States
Phone: (601) 213-4426
Email: info@benchchem.com

[Contact our Ph.D. Support Team for a compatibility check](#)