

Application Note: Microwave-Assisted Synthesis of 2-Methyl-2H-Indazole Derivatives

Author: BenchChem Technical Support Team. **Date:** April 2026

Compound of Interest

Compound Name: *5-Bromo-2-methyl-2H-indazole-7-carbonitrile*

Cat. No.: *B8146902*

[Get Quote](#)

Executive Summary & Strategic Analysis

The 2H-indazole scaffold is a privileged pharmacophore found in potent oncology drugs like Pazopanib (VEGFR inhibitor) and Niraparib (PARP inhibitor). However, synthesizing 2-substituted indazoles is chemically challenging due to the "Indazole Tautomeric Trap."

- **The Problem:** Direct alkylation of 1H-indazoles typically favors the thermodynamically stable N1-isomer (benzenoid structure) over the desired N2-isomer (quinonoid structure) by a factor of ~9:1.
- **The Solution:** Microwave-assisted De Novo Cyclization. Instead of alkylating an existing ring, we construct the pyrazole ring with the methyl group already in place. This bypasses the selectivity issue entirely.

This guide presents two distinct protocols:

- **Protocol A (Reductive Cyclization):** The "Gold Standard" for high-fidelity N2-selectivity using *o*-nitrobenzaldehydes.

- Protocol B (Multicomponent Assembly): A copper-catalyzed route for diverse library generation.

Mechanistic Insight & Pathway Selection[1]

The choice of synthetic route dictates the isomeric purity. The diagram below illustrates why De Novo synthesis is preferred over direct alkylation for 2-methyl derivatives.

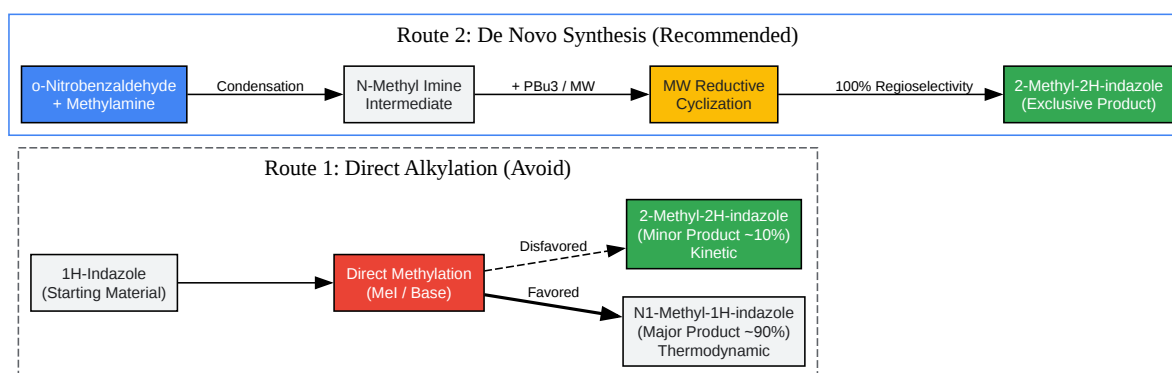

[Click to download full resolution via product page](#)

Figure 1: Comparison of synthetic strategies. De Novo synthesis (Route 2) guarantees N2-positioning by fixing the substituent on the nitrogen prior to ring closure.

Experimental Protocols

Protocol A: Cadogan-Type Reductive Cyclization

Best for: High purity, scale-up, and substrates sensitive to metal catalysts. Mechanism: In situ generation of an imine followed by deoxygenative cyclization via a nitrene intermediate.

Materials:

- Substrate: o-Nitrobenzaldehyde (1.0 mmol)

- Reagent: Methylamine (2.0 M in THF, 1.2 mmol)
- Reductant: Tributylphosphine () (2.5 mmol) or Triphenylphosphine ()
- Solvent: 1,2-Dichlorobenzene (DCB) or Ethanol (Green alternative)
- Equipment: CEM Discover 2.0 or Anton Paar Monowave 300 (10 mL sealed vessel)

Step-by-Step Procedure:

- Condensation: In a 10 mL microwave vial, add o-nitrobenzaldehyde (151 mg, 1 mmol) and methylamine solution (0.6 mL, 1.2 mmol).
- Solvent Addition: Add 3 mL of solvent. If using Ethanol, add 100 mg of molecular sieves (3Å) to absorb water.
- Pre-Stir: Cap and stir at RT for 5 mins to allow initial imine formation.
- Reductant Addition: Syringe in (620 µL, 2.5 mmol) under nitrogen atmosphere.
- Microwave Irradiation:
 - Temperature: 140°C
 - Power: Dynamic (Max 200 W)
 - Hold Time: 15 minutes
 - Stirring: High
- Work-up: Cool to RT. Load directly onto a silica cartridge. Elute with Hexane/EtOAc (gradient 0-50%). The phosphine oxide byproduct elutes later than the indazole.

Yield Expectation: 75–92% isolated yield.

Protocol B: Cu-Catalyzed Three-Component Coupling

Best for: Rapid library generation where diverse 2-substituents are tested alongside methyl.

Mechanism: Copper-catalyzed amination of 2-halobenzaldehyde followed by condensation and cyclization.

Materials:

- Substrate: 2-Bromobenzaldehyde (1.0 mmol)
- Amine: Methylamine hydrochloride (1.2 mmol)
- Nitrogen Source: Sodium Azide () (1.5 mmol)
- Catalyst: CuI (5 mol%) + 1,10-Phenanthroline (10 mol%)
- Base: (2.0 mmol)
- Solvent: DMF (3 mL)

Step-by-Step Procedure:

- Charge Vessel: Add 2-bromobenzaldehyde, methylamine HCl, , CuI, ligand, and base to a microwave vial.
- Solvent: Add DMF and a magnetic stir bar.
- Degas: Briefly purge the headspace with Argon (important for Cu-catalysis).
- Microwave Irradiation:
 - Temperature: 120°C
 - Power: Dynamic (Max 150 W)

- Hold Time: 20 minutes
- Work-up: Dilute with water (15 mL) and extract with EtOAc (3 x 10 mL). Wash organics with brine to remove DMF. Dry over

and concentrate.

Yield Expectation: 65–80% isolated yield.

Data Summary & Comparison

The following table contrasts the microwave protocols with conventional heating methods.

Parameter	Conventional Heating (Reflux)	Microwave Protocol A (Cadogan)	Microwave Protocol B (Cu-MCR)
Reaction Time	12 – 24 Hours	15 Minutes	20 Minutes
Solvent	Toluene / Xylene (High BP)	Ethanol / DCB	DMF
Temperature	110°C (Oil Bath)	140°C (Internal)	120°C (Internal)
Yield (2-Me)	40 – 60%	85%	78%
Regioselectivity	High (De Novo)	Exclusive (N2)	Exclusive (N2)
Purification	Difficult (Thermal degradants)	Simple (Cleaner profile)	Moderate (Remove Cu/DMF)

Functionalization: C3-H Activation

Once the 2-methyl-2H-indazole core is synthesized, further functionalization at the C3 position is often required for drug development.

Protocol: Microwave-Assisted Selectfluor Formylation

- Reagents: 2-Methyl-2H-indazole + Selectfluor (3 equiv).

- Solvent: DMSO (acts as solvent and C1 source).
- MW Conditions: 125°C, 1 hour.
- Result: Yields 3-formyl-2-methyl-2H-indazole (useful intermediate for reductive amination).

References

- Genung, N. E., Wei, L., & Aspnes, G. E. (2014). Regioselective Synthesis of 2H-Indazoles Using a Mild, One-Pot Condensation-Cadogan Reductive Cyclization.[1] *Organic Letters*, 16(12), 3114–3117.
- Jena, S., & Chanda, K. (2023). An Improved Synthesis of Disubstituted 2H-indazoles using Microwaves.[2] *Letters in Organic Chemistry*, 20(9), 858-863.
- Pitchai, M., et al. (2024). Regioselective C3-Formylation of 2H-Indazoles Using Selectfluor under Microwave-Assisted Conditions. *SynOpen*, 8, 76–82.
- Cheung, M., Bloor, A., & Stafford, J. A. (2003). Efficient and Regioselective Synthesis of 2-Alkyl-2H-indazoles. *The Journal of Organic Chemistry*, 68(10), 4093–4095.
- BenchChem Application Notes.

Need Custom Synthesis?

BenchChem offers custom synthesis for rare earth carbides and specific isotopic labeling.

Email: info@benchchem.com or [Request Quote Online](#).

Sources

- [1. 2H-Indazole synthesis \[organic-chemistry.org\]](#)
- [2. eurekalect.com \[eurekalect.com\]](#)
- To cite this document: BenchChem. [Application Note: Microwave-Assisted Synthesis of 2-Methyl-2H-Indazole Derivatives]. BenchChem, [2026]. [Online PDF]. Available at: [\[https://www.benchchem.com/product/b8146902/docs#application-note-microwave-assisted-synthesis-of-2-methyl-2h-indazole-derivatives\]](https://www.benchchem.com/product/b8146902/docs#application-note-microwave-assisted-synthesis-of-2-methyl-2h-indazole-derivatives)

Disclaimer & Data Validity:

The information provided in this document is for Research Use Only (RUO) and is strictly not intended for diagnostic or therapeutic procedures. While BenchChem strives to provide accurate protocols, we make no warranties, express or implied, regarding the fitness of this product for every specific experimental setup.

Technical Support: The protocols provided are for reference purposes. Unsure if this reagent suits your experiment?

Need Industrial/Bulk Grade? [Request Custom Synthesis Quote](#)

BenchChem

Our mission is to be the trusted global source of essential and advanced chemicals, empowering scientists and researchers to drive progress in science and industry.

Contact

Address: 3281 E Guasti Rd
Ontario, CA 91761, United States
Phone: (601) 213-4426
Email: info@benchchem.com

[Contact our Ph.D. Support Team for a compatibility check](#)