

Navigating Chemical Space: A Comparative Guide to Polyhalogenated Scaffolds in Combinatorial Chemistry

Author: BenchChem Technical Support Team. **Date:** April 2026

Compound of Interest

Compound Name: *1,3-Dibromo-4,6-difluoro-2-iodobenzene*
Cat. No.: *B8145866*

[Get Quote](#)

A note to the reader: Initial research into the utility of "**1,3-Dibromo-4,6-difluoro-2-iodobenzene**" for combinatorial chemistry revealed a significant gap in publicly available data. This specific molecule appears to be a highly specialized or novel reagent with limited documentation, making a direct comparative analysis impracticable. To provide a valuable and data-supported guide, this document has been pivoted to address the broader, yet critically important, topic of selecting polyhalogenated aromatic scaffolds for diversity-oriented synthesis. We will explore the principles of orthogonal reactivity and compare commonly available building blocks to empower researchers in their library design and drug discovery efforts.

Introduction: The Power of Halogens in Building Molecular Diversity

In the landscape of modern drug discovery and materials science, combinatorial chemistry serves as a powerful engine for innovation.^[1] By systematically and rapidly synthesizing large libraries of related compounds, researchers can efficiently explore vast regions of chemical space to identify molecules with desired properties.^{[2][3]} Central to this strategy is the use of

versatile chemical scaffolds—core structures that can be elaborated with a variety of functional groups.

Polyhalogenated aromatic compounds are exemplary scaffolds, offering multiple, distinct reaction handles for diversification.^{[4][5]} The differential reactivity of carbon-halogen bonds (C-I > C-Br > C-Cl) in transition metal-catalyzed cross-coupling reactions allows for a programmed, site-selective functionalization of the aromatic core.^{[6][7]} This principle, often termed "orthogonal reactivity," enables the construction of complex, multi-substituted molecules from a single, readily available starting material. This guide will compare and contrast several common polyhalogenated benzene derivatives, providing a framework for selecting the optimal scaffold for your combinatorial library synthesis.

The Contenders: A Comparative Overview of Polyhalogenated Scaffolds

The choice of a polyhalogenated scaffold is a critical decision in the design of a combinatorial library. It dictates the sequence of reactions, the types of diversity elements that can be introduced, and the overall efficiency of the synthetic campaign. Below, we compare three representative, commercially available building blocks that highlight the strategic considerations in scaffold selection.

Feature	1,3-Dibromo-5-iodobenzene	1-Bromo-3,5-dichlorobenzene	1,3,5-Tribromobenzene
Primary Reactive Site	C-I (Iodine)	C-Br (Bromine)	C-Br (Bromine)
Secondary Reactive Site(s)	C-Br (Bromine)	C-Cl (Chlorine)	C-Br (Bromine)
Reactivity Gradient	High (I vs. Br)	Moderate (Br vs. Cl)	Low (Symmetry can lead to mixtures without directing groups)
Typical First Reaction	Suzuki, Sonogashira, Buchwald-Hartwig at the C-I position.	Suzuki, Sonogashira, Buchwald-Hartwig at the C-Br position.	Mono-functionalization can be challenging to control.
Synthetic Strategy	Sequential, three-step diversification.	Sequential, three-step diversification, requires more forcing conditions for C-Cl.	Often used for symmetrical, threefold additions. ^[8]
Ideal For	Creating highly diverse, unsymmetrical libraries with three distinct points of diversification.	Libraries where two diversity points are introduced under more distinct conditions.	Symmetrical, "star-shaped" molecules or when a directing group is present to break symmetry.

Table 1: Comparative Analysis of Common Polyhalogenated Scaffolds

The primary advantage of a scaffold like 1,3-Dibromo-5-iodobenzene lies in its pronounced reactivity gradient. The carbon-iodine bond is significantly more reactive towards palladium-catalyzed cross-coupling than the carbon-bromine bonds.^[6] This allows for a clean, selective reaction at the iodo-position under mild conditions, leaving the two bromo-positions untouched for subsequent, more forcing reaction conditions.

In contrast, 1-Bromo-3,5-dichlorobenzene offers a more subtle reactivity difference between the C-Br and C-Cl bonds. While selective functionalization of the C-Br bond is readily achievable,

subsequent reactions at the C-Cl positions typically require more active catalysts, stronger bases, or higher temperatures.[9] This can be an advantage when a greater degree of stability is required for the secondary reactive sites during the initial coupling step.

1,3,5-Tribromobenzene presents a unique case. Due to its C₃ symmetry, all three bromine atoms are electronically and sterically equivalent. This can make selective mono-functionalization challenging, often leading to mixtures of mono-, di-, and tri-substituted products. However, this scaffold is ideal for the synthesis of symmetric molecules or in cases where a directing group can be used to break the symmetry and guide the reaction to a specific position.[10]

The Chemistry of Selectivity: A Deeper Dive into Cross-Coupling Reactions

The workhorse of scaffold diversification is the palladium-catalyzed cross-coupling reaction. The Suzuki-Miyaura coupling, in particular, is widely used due to the stability and commercial availability of boronic acid coupling partners.[11][12] The generally accepted order of reactivity for aryl halides in the rate-determining oxidative addition step is I > OTf > Br >> Cl.[11][13]

This differential reactivity is the key to sequential, site-selective functionalization. For a molecule like 1,3-Dibromo-5-iodobenzene, a typical synthetic workflow would involve:

- Step 1 (C-I Functionalization): A Suzuki-Miyaura coupling at the C-I position using a mild base (e.g., Na₂CO₃ or K₃PO₄) and a standard palladium catalyst (e.g., Pd(PPh₃)₄ or Pd(dppf)Cl₂).
- Step 2 (C-Br Functionalization): A second, different Suzuki-Miyaura coupling at one of the C-Br positions, often requiring a more active catalyst system (e.g., using bulky, electron-rich phosphine ligands) and a stronger base.[14]
- Step 3 (Final C-Br Functionalization): A third coupling reaction to introduce the final element of diversity.

This stepwise approach allows for the controlled introduction of three different building blocks, leading to a high degree of molecular diversity from a single scaffold.

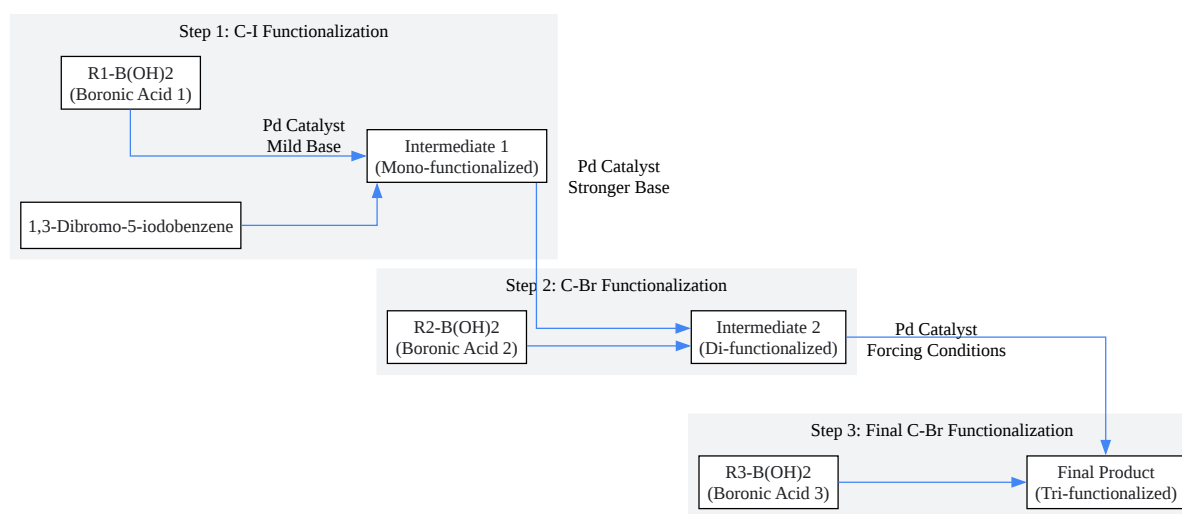

[Click to download full resolution via product page](#)

Figure 1: A generalized workflow for the sequential, site-selective Suzuki-Miyaura coupling of a polyhalogenated scaffold.

Experimental Protocol: A Self-Validating System for Selective Suzuki-Miyaura Coupling

The following protocol provides a detailed, step-by-step methodology for the selective mono-arylation of 1,3-Dibromo-5-iodobenzene at the C-I position. This serves as a foundational experiment for any combinatorial library synthesis using this scaffold.

Reaction: Selective Suzuki-Miyaura Coupling of 1,3-Dibromo-5-iodobenzene with Phenylboronic Acid.

Materials:

- 1,3-Dibromo-5-iodobenzene (1.0 eq)
- Phenylboronic acid (1.2 eq)
- [1,1'-Bis(diphenylphosphino)ferrocene]dichloropalladium(II) (Pd(dppf)Cl₂) (0.03 eq)
- Potassium carbonate (K₂CO₃) (3.0 eq)
- 1,4-Dioxane
- Water
- Ethyl acetate
- Brine
- Anhydrous magnesium sulfate

Procedure:

- To a flame-dried round-bottom flask equipped with a magnetic stir bar and a reflux condenser, add 1,3-Dibromo-5-iodobenzene, phenylboronic acid, and potassium carbonate.
- Evacuate and backfill the flask with an inert atmosphere (e.g., argon or nitrogen) three times.
- Add Pd(dppf)Cl₂ to the flask.
- Add a degassed 4:1 mixture of 1,4-dioxane and water via syringe.
- Heat the reaction mixture to 80 °C and stir for 12-16 hours, monitoring the reaction progress by TLC or LC-MS.
- Upon completion, cool the reaction mixture to room temperature and dilute with ethyl acetate.

- Wash the organic layer sequentially with water and brine.
- Dry the organic layer over anhydrous magnesium sulfate, filter, and concentrate under reduced pressure.
- Purify the crude product by column chromatography on silica gel to yield the desired mono-arylated product.

Self-Validation: The success of this protocol is validated by the selective consumption of the starting material and the formation of a single major product, with the two bromine atoms remaining intact. This can be confirmed by ¹H NMR, ¹³C NMR, and mass spectrometry. The expected outcome is a high yield (>80%) of 1,3-dibromo-5-phenylbenzene.

Beyond Reactivity: The Role of Halogen Bonding in Fragment-Based Drug Discovery

While the utility of halogens as reactive handles is well-established, their ability to form specific, non-covalent interactions known as "halogen bonds" has gained significant traction in medicinal chemistry.^{[15][16]} A halogen bond is a highly directional interaction between an electropositive region on a halogen atom (the σ -hole) and a Lewis basic site, such as a carbonyl oxygen or a nitrogen atom in a protein backbone.^{[17][18]}

The strength of the σ -hole, and thus the halogen bond, increases from chlorine to bromine to iodine.^[17] This has led to the development of Halogen-Enriched Fragment Libraries (HEFLibs) for use in fragment-based drug discovery.^{[16][18][19]} These libraries are designed to probe for potential halogen bonding interactions in a target's binding site, which can then be exploited to increase ligand affinity and selectivity.^[15]

The choice of a polyhalogenated scaffold can therefore serve a dual purpose: providing handles for synthetic diversification while also embedding the potential for potent halogen bonding interactions in the final library members.

Conclusion and Future Outlook

Polyhalogenated aromatic scaffolds are indispensable tools in combinatorial chemistry, enabling the efficient synthesis of diverse molecular libraries. The principle of orthogonal

reactivity, based on the differential reactivity of carbon-halogen bonds, allows for a programmed and site-selective approach to molecular construction. The choice of scaffold—be it an iodo-dibromo, a bromo-dichloro, or a tribromo derivative—should be a strategic decision based on the desired reactivity profile and the synthetic endgame.

As our understanding of catalysis continues to evolve, we can expect the development of even more selective and efficient methods for the functionalization of these versatile building blocks. [9][20] Furthermore, the growing appreciation for the role of halogen bonding in molecular recognition will undoubtedly spur the design of novel scaffolds that are optimized for both synthetic versatility and biological activity. The continued innovation in this space will undoubtedly accelerate the discovery of new medicines and materials.

References

- Selective and Serial Suzuki–Miyaura Reactions of Polychlorinated Aromatics with Alkyl Pinacol Boronic Esters. *Organic Letters*. Available from: [\[Link\]](#)
- Embracing the Diversity of Halogen Bonding Motifs in Fragment-Based Drug Discovery—Construction of a Diversity-Optimized Halogen-Enriched Fragment Library. *Frontiers in Chemistry*. Available from: [\[Link\]](#)
- Halogen-enriched fragment libraries as chemical probes for harnessing halogen bonding in fragment-based lead discovery. *Future Medicinal Chemistry*. Available from: [\[Link\]](#)
- Halogen-Enriched Fragment Libraries as Leads for Drug Rescue of Mutant p53. *Journal of the American Chemical Society*. Available from: [\[Link\]](#)
- Halogen-Enriched Fragment Libraries as Leads for Drug Rescue of Mutant p53. *ResearchGate*. Available from: [\[Link\]](#)
- Sequential Cross Coupling Reactions of Polyhalogenated Heterocycles. *WuXi Biology*. Available from: [\[Link\]](#)
- Cross-Coupling Reactions of Polyhalogenated Heterocycles. *ResearchGate*. Available from: [\[Link\]](#)
- Alkyl Halides: The Versatile Building Blocks of Chemistry. *Oreate*. Available from: [\[Link\]](#)

- Synthesis and thiolation of 1,3-difluoro-2,4,6-trihaloanilines and benzenes. Vanderbilt University. Available from: [\[Link\]](#)
- Site-Selective Cross-Coupling of Polyhalogenated Arenes and Heteroarenes with Identical Halogen Groups. ResearchGate. Available from: [\[Link\]](#)
- A Short Review on Concept and Types of Combinatorial Chemistry. ResearchGate. Available from: [\[Link\]](#)
- Combinatorial chemistry. Wikipedia. Available from: [\[Link\]](#)
- Exploration of alkyl-based phosphine ligands for palladium-catalyzed chemoselective cross-coupling of polyhalogenated aryl triflates for construction of C(sp²). The Hong Kong Polytechnic University. Available from: [\[Link\]](#)
- Organic Syntheses Procedure. Organic Syntheses. Available from: [\[Link\]](#)
- Combinatorial Chemistry. University of California, Davis. Available from: [\[Link\]](#)
- Site-Selective Cross-Coupling of Polyhalogenated Arenes and Heteroarenes with Identical Halogen Groups. National Center for Biotechnology Information. Available from: [\[Link\]](#)
- Suzuki-Miyaura Coupling. Chemistry LibreTexts. Available from: [\[Link\]](#)
- 1,3-Dibromo-1,1-difluoro-2-propanone as a Useful Synthon for a Chemoselective Preparation of 4-Bromodifluoromethyl Thiazoles. National Center for Biotechnology Information. Available from: [\[Link\]](#)
- Future Applications. University of California, Davis. Available from: [\[Link\]](#)
- Suzuki Coupling. Organic Chemistry Portal. Available from: [\[Link\]](#)
- Suzuki-Miyaura Cross-Coupling in Acylation Reactions, Scope and Recent Developments. MDPI. Available from: [\[Link\]](#)
- Mild and General Conditions for the Cross-Coupling of Aryl Halides with Pentafluorobenzene and Other Perfluoroaromatics. Organic Letters. Available from: [\[Link\]](#)

- Recent Advances in Borylation and Suzuki-Type Cross-Coupling—One-Pot Miyaura-Type C–X and C–H Borylation–Suzuki Coupling Sequence. MDPI. Available from: [[Link](#)]
- Combinatorial Chemistry: Innovations and Applications. Journal of Modern Organic Chemistry. Available from: [[Link](#)]
- Applications of fluorine to the construction of bioisosteric elements for the purposes of novel drug discovery. PubMed. Available from: [[Link](#)]
- 1,3-Dibromo-1,1-difluoro-2-propanone as a Useful Synthon for a Chemoselective Preparation of 4-Bromodifluoromethyl Thiazoles. Figshare. Available from: [[Link](#)]
- Suzuki-Miyaura cross-coupling: Practical Guide. Yoneda Labs. Available from: [[Link](#)]
- Combinatorial Chemistry: A Guide for Librarians. CUNY Academic Works. Available from: [[Link](#)]
- Cross-Coupling and Dehalogenation Reactions Catalyzed by (N-Heterocyclic carbene)Pd(allyl)Cl Complexes. Organic Chemistry Portal. Available from: [[Link](#)]
- 1,3,5-Tribromobenzene. PubChem. Available from: [[Link](#)]
- Solid-phase Synthesis of Combinatorial 2,4-Disubstituted-1,3,5-Triazine via Amine Nucleophilic Reaction. ResearchGate. Available from: [[Link](#)]
- Why can't 1,3,5-tribromobenzene be prepared by direct bromination of benzene? Reddit. Available from: [[Link](#)]

Need Custom Synthesis?

BenchChem offers custom synthesis for rare earth carbides and specific isotopic labeling.

Email: info@benchchem.com or [Request Quote Online](#).

Sources

- 1. openaccessjournals.com [openaccessjournals.com]

- [2. Combinatorial chemistry - Wikipedia \[en.wikipedia.org\]](#)
- [3. Future Applications \[www1.udel.edu\]](#)
- [4. Alkyl Halides: The Versatile Building Blocks of Chemistry - Oreate AI Blog \[oreateai.com\]](#)
- [5. buildingblock.bocsci.com \[buildingblock.bocsci.com\]](#)
- [6. wuxibiology.com \[wuxibiology.com\]](#)
- [7. researchgate.net \[researchgate.net\]](#)
- [8. 1,3,5-Tribromobenzene | C6H3Br3 | CID 12279 - PubChem \[pubchem.ncbi.nlm.nih.gov\]](#)
- [9. pubs.acs.org \[pubs.acs.org\]](#)
- [10. reddit.com \[reddit.com\]](#)
- [11. chem.libretexts.org \[chem.libretexts.org\]](#)
- [12. Suzuki Coupling \[organic-chemistry.org\]](#)
- [13. Yoneda Labs \[yonedalabs.com\]](#)
- [14. Cross-Coupling and Dehalogenation Reactions Catalyzed by \(N-Heterocyclic carbene\)Pd\(allyl\)Cl Complexes \[organic-chemistry.org\]](#)
- [15. Halogen Enriched Fragment Library - Enamine \[enamine.net\]](#)
- [16. Frontiers | Embracing the Diversity of Halogen Bonding Motifs in Fragment-Based Drug Discovery—Construction of a Diversity-Optimized Halogen-Enriched Fragment Library \[frontiersin.org\]](#)
- [17. ovid.com \[ovid.com\]](#)
- [18. pubs.acs.org \[pubs.acs.org\]](#)
- [19. researchgate.net \[researchgate.net\]](#)
- [20. researchgate.net \[researchgate.net\]](#)
- [To cite this document: BenchChem. \[Navigating Chemical Space: A Comparative Guide to Polyhalogenated Scaffolds in Combinatorial Chemistry\]. BenchChem, \[2026\]. \[Online PDF\]. Available at: \[https://www.benchchem.com/product/b8145866/docs#navigating-chemical-space-a-comparative-guide-to-polyhalogenated-scaffolds-in-combinatorial-chemistry\]](#)

Disclaimer & Data Validity:

The information provided in this document is for Research Use Only (RUO) and is strictly not intended for diagnostic or therapeutic procedures. While BenchChem strives to provide

accurate protocols, we make no warranties, express or implied, regarding the fitness of this product for every specific experimental setup.

Technical Support: The protocols provided are for reference purposes. Unsure if this reagent suits your experiment?

Need Industrial/Bulk Grade? [Request Custom Synthesis Quote](#)

BenchChem

Our mission is to be the trusted global source of essential and advanced chemicals, empowering scientists and researchers to drive progress in science and industry.

Contact

Address: 3281 E Guasti Rd

Ontario, CA 91761, United States

Phone: (601) 213-4426

Email: info@benchchem.com

[Contact our Ph.D. Support Team for a compatibility check](#)